



STAYER

DESIGNED FOR PROFESSIONAL



GENERAL CATALOGUE

OCT. 2023 - 2024

ELECTROPORTABLE

WELDING

ACCESSORIES

STAYER

I + D Laboratory
Assembly line
WELDING range



**WELCOME
TO THE STAYER GROUP**



STAYER Technical Service

► **COMPANY 100% SPANISH CAPITAL**, with more than 60 years of experience in the manufacture and distribution of **Power Tools**, **Battery** powered tools, **Welding** equipment and **Abrasive** and **Diamond** Discs.

We are a team of professionals at the service of our clients, with facilities of more than 20,000m².

In **1958** the brand was born in Italy as a specialist in Power Tools for wood, being the first to launch a combined mitre saw including an upper table on the market.

In **1976** the distribution began in the Spanish market through Imaport.

At the end of the 90s, **STAYER IBERICA**, was transformed from a marketer to a manufacturer, dominating the entire value chain for the first time, implementing an integrated business model.

In **1999** the first phase of the current facilities was carried out. In **2000**, the diamond blade factory was inaugurated with the most modern technology, including hot pressing machines and laser welding.

In **2003** the process of expanding the current facilities began, which ended in the following two years.

In **2005**, the assets of the company **STAYER Italy** were acquired, thus becoming **STAYER IBERICA** the manufacturer of the products and the continuation of all the activity of the Italian company.

In **2005** **STAYER Italy** was established in the city of Schio, in the province of Vicenza.

At the end of **2020**, the construction of a **new logistics** center began, doubling our storage capacity.

In **2021**, a system with **7 automated intelligent** storages with 10 meters high is installed.

In **2022** the construction of a new warehouse in Madrid began, improving our logistics.

In July **2022**, a **250-kW** photovoltaic energy system with solar panels is installed on the company's roof. As the company grows, our commitment to sustainability and social responsibility increases.



Warehouses
STAYER

Assembly line
STAYER

Diamond Tools Factory
ABRASIVOS GRINDING



Central Offices
STAYER GROUP



ISO 9001

Stayer is certified for the quality system: product development, analysis laboratory, assembly, product control and distribution, etc., which is proof of the team's commitment to continuous quality improvement.



OUR BUSINESS MODEL



PRODUCT RANGE



We have an **INTEGRATED** Business model, through which we can **CONTROL** the entire product value chain

The increasingly complex international demand, the rapidity in the evolution of technologies and the most demanding competition, pose the most relevant day-to-day challenges in our company.

Our main purpose is the development of innovation in all areas of the organization, with continuous improvement in our production processes, offering new products that meet the needs of our customers with exclusive, versatile, and durable designs.

Our determination to achieve the perfect symbiosis between Quality and Price is the continuous challenge that we face with the deepest tenacity.

All our equipment is subject to the strictest quality tests in our laboratories with a detailed and constant follow-up always carried out under the supervision of our engineers, verifying by means of state-of-the-art measurement equipment that each one of our creations always comply with the highest European and International Quality Standards.

STAYER goes one step further in its quality controls. For us, quality is not a mere matter of technological, scientific or safety approval by certifying bodies or institutions, but the approval by our clients that each of our equipment meets their expectations under the most severe conditions of real work, subjecting them to rigorous field tests prior to their launch on the market



RANGE STAYER

All our prototypes, prior to their commercialization, are subjected by our technical staff to a period of testing and experimentation in our Electronics Laboratory and Mechanics Laboratory, in which the most demanding pertinent power and resistance tests are carried out, load tests, electromagnetic pollution, etc... necessary, until reaching the highest quality standards that allow us to start production



WELDING

MACHINES



BATTERIES



DISCS



ACCESSORIES

STAYER establishes programmed quality controls at four points:



1. Selection of components.
2. Assembly.
3. Random test of each production.
4. Benchmarking, which our R&D department develops throughout the life of the product for its continuous improvement and updating.

STAYER

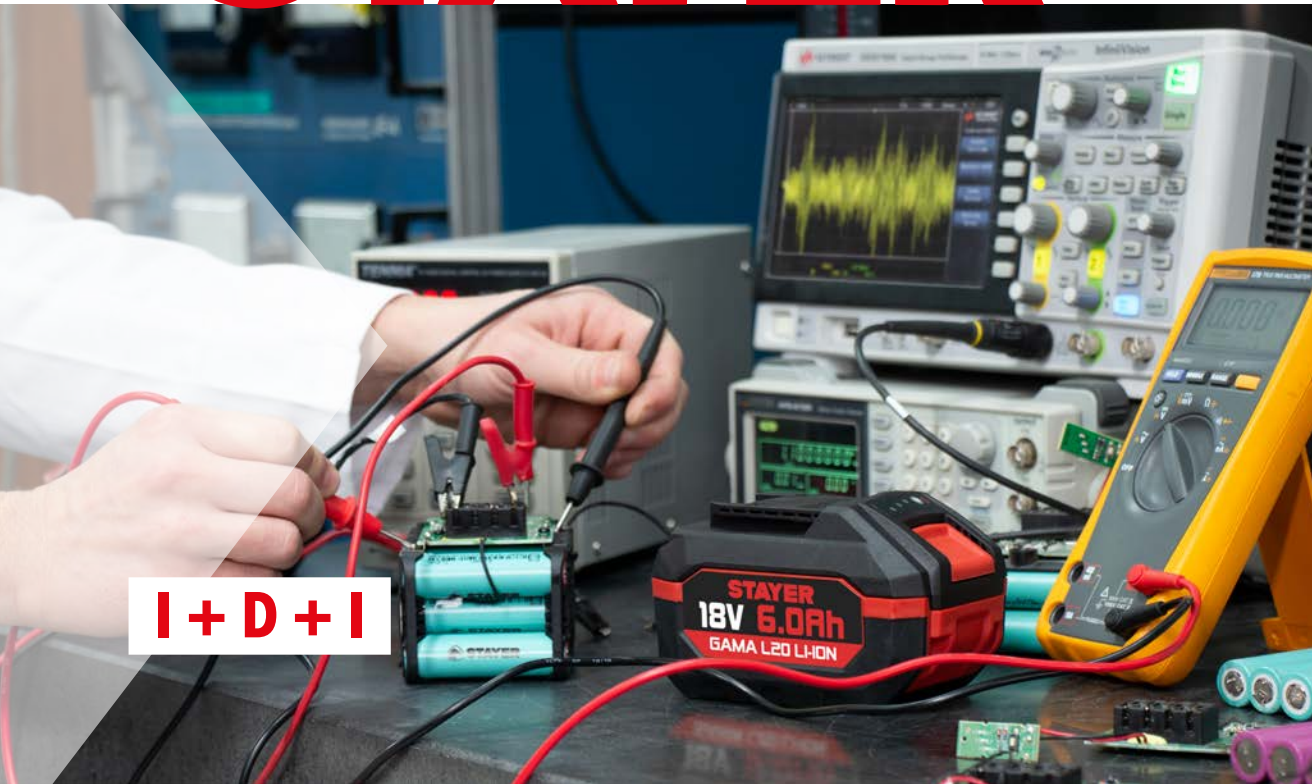

► TECHNICAL OFFICE,

Specialist team: Composed by engineers, electronic and mechanic technicians.

► COMPANY KNOW-HOW

Collaboration agreements with the most prestigious laboratories and certification bodies, for the development and improvement of products: SGS, Dekra, UPM, Nebrija, Carlos III, TÜV.

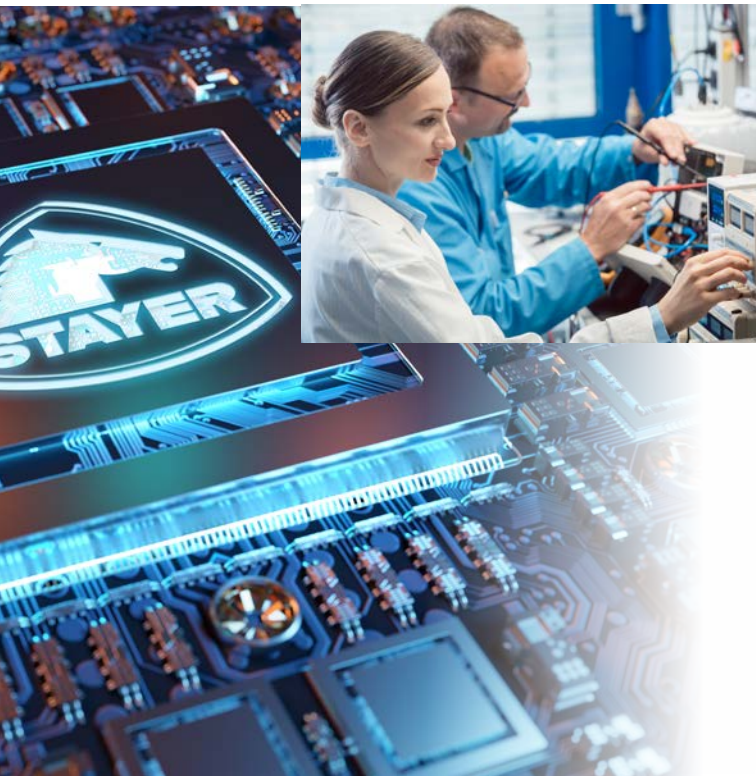

POLITÉCNICA





PRODUCTION

► **WE ARE SPANISH MANUFACTURERS,** with operating centers in Spain, Portugal, and Asia, in addition to collaborating with international manufacturers, in the development of new products.

We participate in the management of two factories located in Asia, and we collaborate with international producers

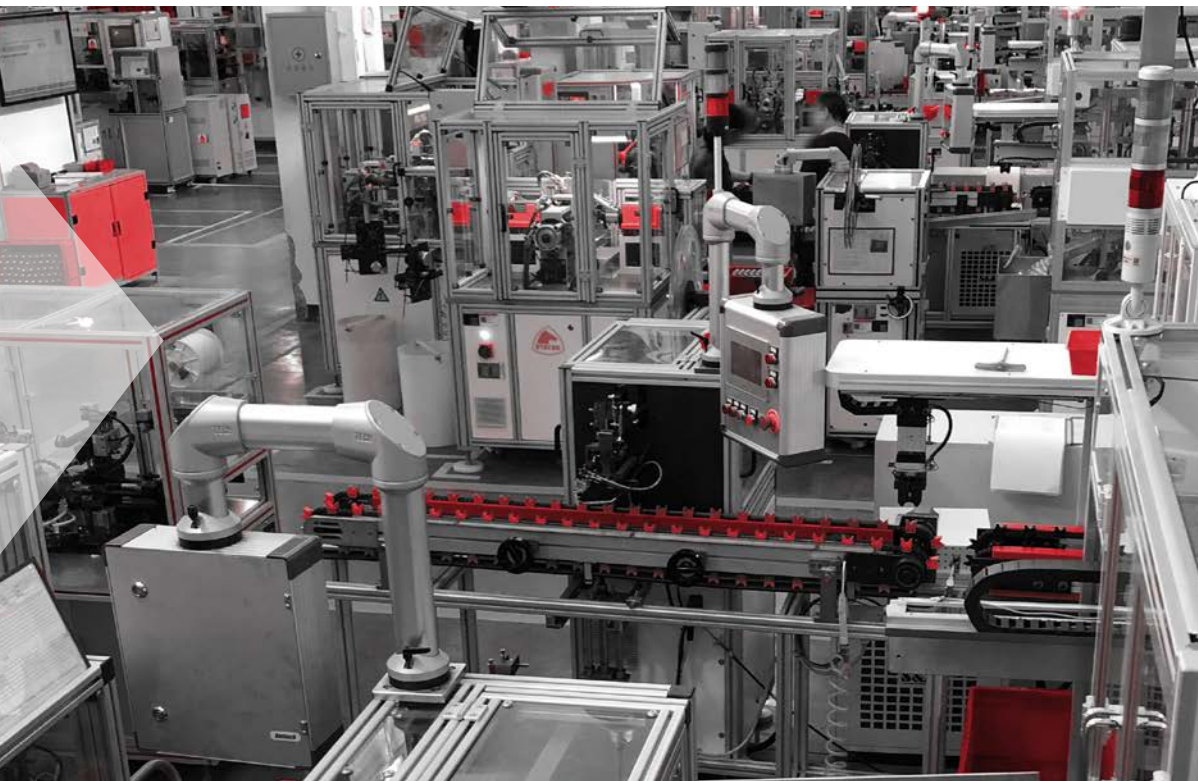

STAYER



INVERTER // WELDING

- 1.** Development in recent years of small-sized inverter equipment (<2 kg) and professional features, with 100% duty cycle. All this has caused an evolution in the sector that has been very well accepted by professionals.
- 2.** Design of PCB boards, external manufacturing following the guidelines of our R&D department.
- 3.** Assembly of the logic board and verification and graduation of all the equipment in Madrid.
- 4.** Test of 2% of the tested equipment and professional welders in the test area.
- 5.** Level of incidence less than 1% in all welding equipment.



IN OUR LABORATORY we have an assembly line, in which our specialized technicians review and adjust each piece of every equipment.

We program our own software developed in Spain and exclusive for our welding equipment, installed on our 32-bit microprocessor.

Specialized engineers oversee improving, updating, testing, and verifying that each component, equipment, and prototype meets the highest quality standards



ABRASIVE DISCS

► **STAYER GROUP** participates in the ownership and management of an abrasive disc factory in Asia, and we are partners of European factories.

Continuous and standardized tests of performance and quality of STAYER discs and those of the competition, which allow us to guarantee the best levels of performance of our discs.

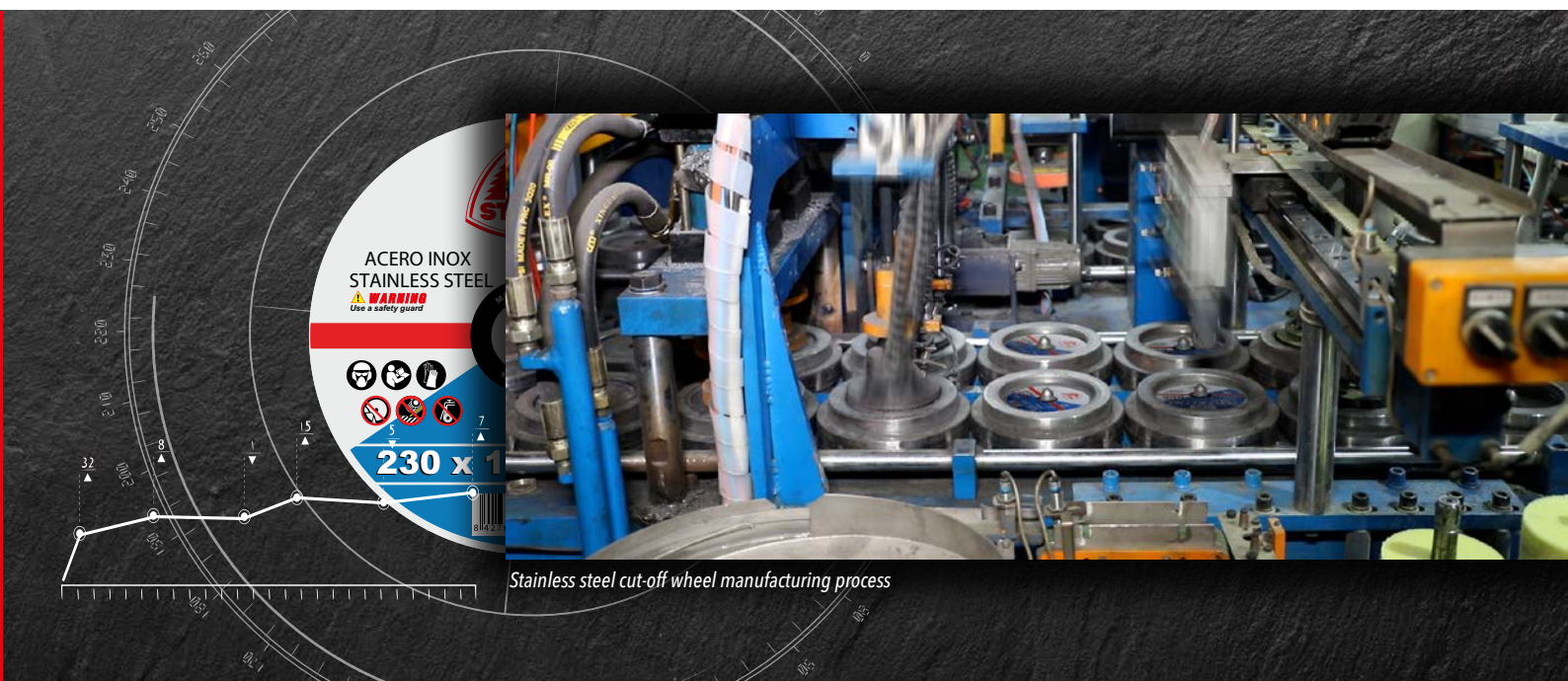

ACERO INOX
STAINLESS STEEL

⚠️ **WARNING**
Use a safety guard



230 x 1

Stainless steel cut-off wheel manufacturing process



**PRODUCTION,
ASSEMBLY and PACKAGING**

Miter saw assembly line

STAYER

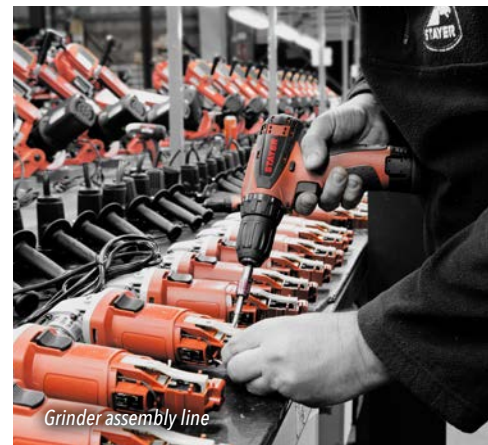

Grinder assembly line





► **IN CLOSE COLLABORATION,** STAYER's Production, Assembly and Packaging departments develop our products always using the highest quality mechanical and electronic components.

Our R&D department, after designing and testing the quality of the components to be used, given the green light to the production and assembly of all our models,

which through prior quality control are packaged using the most innovative systems of packaging always ensuring the reliability of the product packaging.

All our Production, Assembly and Packaging lines are tested and ergonomically adapted to each job, thus ensuring their perfect adaptation to safety at work and personal care of our employees.



FACTORY OF DIAMOND DISCS

Segment pressing line



Nuevo centro logístico C/Transportistas



- 3 logistics centers in Spain
- Capacity for **12.500** pallets
- 7 automated 10m high Intelligent Warehouses
- Manage more than **28.000** pieces (to provide speed of service) and ensure ensure immediate availability.

STAYER

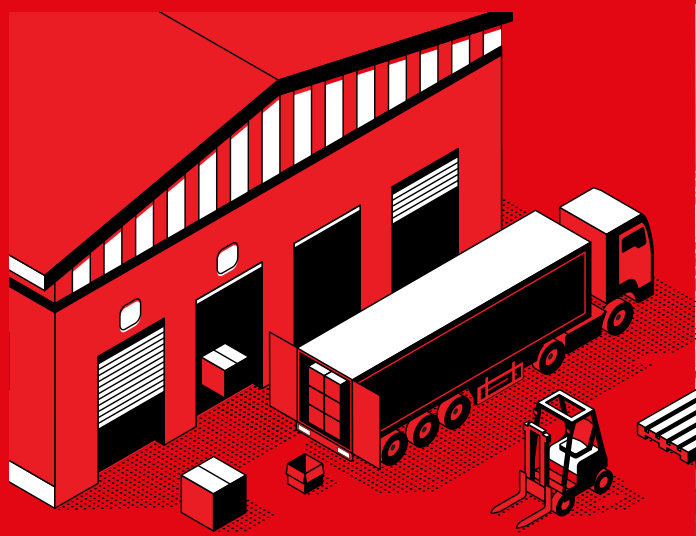

PLUS CODES:

- 7873+P2 Pinto
- 67WC+QP Pinto
- 7896+PG Pinto



Logistics Center C/ Ronda

LOGISTICS



▶ OUR MAIN OPERATING CENTER

is integrated with a warehouse, laboratory, and factory. In addition, the entire process from order preparation to picking is automated.

Our ERP, is integrated with the WMS of clients, Online platforms and with the systems of order automation: EDI...



Logistics center C/ Sierra de Cazorla

STAYER



SUSTAINABILITY

▶ DIGITALIZATION

of the departments: Reducing the use of paper, increasing the use of brochures and digital catalogues.

RENEWABLE ENERGIES:

Solar panels that generate 250 kW.

PACKAGING OPTIMIZATION

Reducing the use of cardboard, adjusting the sizes to the maximum.

PLASTIC

We have eliminated or reduced as much as possible the use of non-reusable or non-recycled plastic in our packaging.

LONGER LIFE FOR TOOLS

As we improve our products, we reduce the generation and treatment of waste.

LESS POLLUTION:

We're ditching our range of petrol-powered garden tools for more sustainable battery-powered solutions



▶ WASTE MANAGEMENT

RECYCLIA: CCollection of electrical and electronic waste (WEEE'S) and batteries and accumulators.

ECOEMBES: Collection of cardboard, plastic containers.

SAFETYKLEEN: Chemical.

RECYCLAUTO: Waste from the Diamond discs factory.





STAYER & INTERNATIONAL

Andorra	Spain	Latvia	Rep. of Guine
Argentina	Estonia	Liechtenstein	Democratic
Armenia	Finland	Lithuania	Rep. of the
Bahrain	France	Luxembourg	Congo
Belgium	Gabon	Malta	Rep. of
Brazil	Germany	Morocco	Macedonia
Bulgaria	Greece	Mexico	Dominican
Cameroon	Guatemala	Norway	Republic
Czech Republic	Netherlands	New Caledonia	Romania
Chile	Hungary	Panama	Senegal
Cyprus	Iraq	Peru	Serbia
Colombia	Ireland	French Poly-	Switzerland
Ivory Coast	Iceland	nesia	Tunisia
Costa Rica	Israel	Poland	Turkey
Croatia	Italy	Portugal	Uruguay
Slovenia	Jordan	Qatar	

► **CHASE OF A COMPETITIVE ADVANTAGE** lies in our ability to understand and adapt to the changing dynamics of international markets. We draw on our experience and in-depth knowledge of the different cultures, regulations, and economic trends of the more than 70 countries to which we export.

We work closely with local partners in each country, allowing us to quickly adapt to consumer tastes and preferences in each market. This strategy has allowed us to offer highly relevant and competitive products and services to our international partners, of which 63% are in Europe, 25% in South America, 9% in Africa and 3% in Asia.

Our continue investment in research and development allows us to stay at the forefront of innovation in our industry. We develop advanced products and solutions that meet the specific needs of each international market.

Excellence in supply chain management is also a fundamental pillar of our competitive advantage. We have a global network of first-class logistics providers, which allows us to offer high-quality products in a timely manner and at competitive prices in the more than 70 countries in which we have a presence.

In short, our vision of international development, backed by our extensive experience, translates into a strong and sustainable competitive advantage for Stayer. Through our deep understanding of international markets, our strategic alliances, our capacity for innovation and our excellence in supply chain management, we are ready to excel in an increasingly dynamic global environment.

"Trust STAYER to be your trusted partner in the international growth of your company."





STAYER

SPONSORSHIPS & PARTNERSHIPS



Sponsorship Formula Gades



Monoplaza Dynamics UPC Manresa

► STAYER HAS COLLABORATION agreements with prestigious laboratories and certifiers such as SGS, Dekra, UPM, Nebrija, Carlos III or TÜV, for product development and improvement.

In addition, the FabLab Etsidi Ingenia of the Higher Technical School of Engineering and Industrial Design of the Polytechnic University of Madrid, where for the last 9 years he has given presentations and exhibitions for future engineers.



► STAYER SPONSORS Formula Student teams in international automobile competitions. Formula Gades and Formula Dynamics UPC Manresa, composed by students from the Engineering School of the University of Cádiz and the Polytechnic School of Engineering University of Manresa, respectively, in charge of managing, designing and manufacturing small formula-style race cars.

For Formula Gades, it is the fifth year participating and for Formula Dynamics UPC Manresa, the sixth, and both have been classified for competitions in Austria, the Czech Republic, the Netherlands, Italy, and Spain.

The materialization of the single seater is fundamental, for this reason, welding equipment as well as a quality power tools are needed to help carry it out.

This is where STAYER, which is also committed to the design of state-of-the-art professional power tools, wants to contribute both sponsorship and machinery.

But in this competition, not only manufacturing matters, but details such as the technical and economic characteristics of the design, the business plan and the business viability of the project also count.

PROFESSIONAL LINE

INDEX



Cordless tools	17
L20 Series - 18V	18
L12 Series - 12V	40
3.6 / 12V Tools	42
Batteries & Chargers	42



Electric Drills/Screwdrivers	43
Screwdriver /Drills	44
Percussion Drills	45
Impact Wrench	46



Hammers	47
SDS-PLUS Rotary Hammers	48
SDS-MAX Rotary Hammers	50
SDS-PLUS, SDS-MAX & HEX 30 Demolition hammers	52



Mixers, Hot air gun and Wall Sanders	53
Hot air guns	54
Mixers	55
Telescopic wall sanders	57
Hand wall sanders	59



Angle Grinders	61
Mini Angle Grinders	62
Angle Grinders	65
Die grinders & Dual saw	68



Tools for Wood, Metal & Construction	69
Wall Chasers	70
Circular Saws	72
Jig Saws	76
Reciprocating Saws	77
Oscillating Multi tool	77
Polishers	78
Rotorbital Sanders	79
Orbital Sanders	80
Belt Sander / Planer / Biscuit Jointer	81
Routers	82
Blower & Vacuum Cleaners	83



Mitre Saws, Band Saws and Chop Saws	85
Mitre Saws ø210 mm	86
Mitre Saws ø250 mm	87
Mitre Saws ø300 mm	89
Telescopic Mitre Saws	91
Chop Saws	93
Band Saws	94



STAYER

WIRELESS UNLIMITED

18V L20 Range

Professional Quality



YouTube

Battery Tools



DRILL / HAMMER DRILL / SCREWDRIVER 18V

PB 18 B L20 PK

No load speed	0-350/0-1350	rpm
Impacts	0-600 / 0-22500	ipm
Chuck Capacity	ø2 - ø10	mm
Tightening Torque	30	Nm
Settings	25	
Max. wood drilling	ø26	mm
Max. masonry drilling	ø10	mm
Max. steel drilling	ø6	mm
Weight	1	kg

- 18V battery drill.

3 Functions:

Drill, Screwdriver & Hammer drill.

- Automatic chuck with safety lock.
- Clutch with 25 adjustment points for tightening limit control.
- L.E.D. guide light.
- 2 Mechanical speeds: Max. torque. Less reductions
Max. Reductions. Less torque
- Reversible and electronic with microprocessor.



NEW



PB 18 B L2022 PK	2 x 2.0Ah	<input checked="" type="checkbox"/>	<input checked="" type="checkbox"/>	1.3050
-------------------------	------------------	-------------------------------------	-------------------------------------	---------------

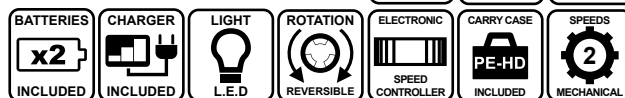

DRILL / HAMMER DRILL / SCREWDRIVER 18V

PBL 20 1822 PK

No load speed	0-400/0-1350	rpm
Impacts	0-6000/22000	ipm
Chuck Capacity	ø2 - ø10	mm
Tightening Torque	32	Nm
Settings	21 + 3	
Max. wood drilling	ø30	mm
Max. masonry drilling	ø10	mm
Max. steel drilling	ø10	mm
Weight	1.2	kg

- Cordless drill with motor 550

3 Functions:

Drill, Screwdriver & Hammer drill.

- Keyless Chuck with safety lock.
- 21+1+1+1 set points clutch for precise tightening limits.
- Belt clip.
- L.E.D. guide light.
- 2 Mechanical speeds: Max. torque. Less reductions
Max. Reductions. Less torque
- Reversible and electronic with microprocessor.



PBL 20 1822 PK	2 x 2.0Ah	<input checked="" type="checkbox"/>	<input checked="" type="checkbox"/>	1.2465
-----------------------	------------------	-------------------------------------	-------------------------------------	---------------

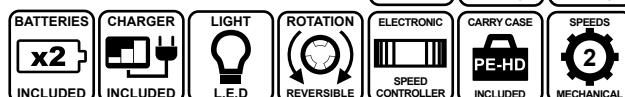

DRILL / HAMMER DRILL / SCREWDRIVER 18V

PBL 21 P - L20

No load speed	0-440/0-1650	rpm
Impacts	0-7920/0-29700	ipm
Chuck Capacity	ø2 - ø13	mm
Tightening Torque	50	Nm
Settings	20 + 3	
Max. wood drilling	ø40	mm
Max. masonry drilling	ø13	mm
Max. steel drilling	ø13	mm
Weight	1.5	kg

- Cordless drill with motor Premium S1

3 Functions:

Drill, Screwdriver & Hammer drill.

- Keyless Chuck with safety lock.
- 20+1+1+1 set points clutch for precise tightening limits.
- Belt clip.
- L.E.D. guide light.
- 2 Mechanical speeds: Max. torque. Less reductions
Max. Reductions. Less torque
- Reversible and electronic with microprocessor.
- Auxiliary handle.
- Magnet for tips



PBL 21 P - L20	X	X	X	1.2307
PBL 2122 PK	2 x 2.0Ah	<input checked="" type="checkbox"/>	<input checked="" type="checkbox"/>	1.2199
PBL 2124 PK	2 x 4.0Ah	<input checked="" type="checkbox"/>	<input checked="" type="checkbox"/>	1.2175
PBL 2125 PK	2 x 5.0Ah	<input checked="" type="checkbox"/>	<input checked="" type="checkbox"/>	1.2340





DRILL / HAMMER DRILL / SCREWDRIVER 18V

PBL 50 BRUSHLESS L20

No load speed	0-450 / 0-1550	rpm
Impacts	0-30000	ipm
Chuck Capacity	ø2 - ø13	mm
Tightening Torque	50	Nm
Settings	20 + 3	
Max. wood drilling	ø45	mm
Max. masonry drilling	ø13	mm
Max. steel drilling	ø13	mm
Weight	1.0	kg

BRUSHLESS motor:
Increased performance and service life.

3 Functions

Drill, Screwdriver & Hammer drill.

- Automatic chuck with 13mm safety locking.
- Clutch with 20+1+1+1+1 adjustment points for tightening limit control.
- L.E.D. guide light.
- 2 Mechanical speeds:
- Max. torque. Less reductions
- Max. Reductions. Less torque
- Reversible and electronic with microprocessor.



NEW
Check availability



PBL 50 BRUSHLESS	X	X	X	1.3059
PBL 50 2022 PK BRUSHLESS	2 x 2.0Ah	✓	✓	1.2964
PBL 50 2024 PK BRUSHLESS	2 x 4.0Ah	✓	✓	1.2965
PBL 50 2025 PK BRUSHLESS	2 x 5.0Ah	✓	✓	1.2966

DRILL / HAMMER DRILL / SCREWDRIVER 18V

PB L20 BRUSHLESS (60Nm)

No load speed	0-500/0-2000	rpm
Impacts	0-7500/0-30000	ipm
Chuck Capacity	ø2 - ø13	mm
Tightening Torque	60	Nm
Settings	21 + 3	
Max. wood drilling	ø45	mm
Max. masonry drilling	ø13	mm
Max. steel drilling	ø13	mm
Weight	1.2	kg

BRUSHLESS motor:
Increased performance and service life.

3 Functions

Drill, Screwdriver & Hammer drill.

- Automatic chuck with 13mm safety lock.
- Clutch with 20+1+1+1+1 adjustment points for tightening limit control.
- Belt clip.
- L.E.D. guide light.
- 2 Mechanical speeds:
- Max. torque. Less reductions
- Max. Reductions. Less torque
- Reversible and electronic with microprocessor.

2 mechanical speeds



21 + 3 Settings

Reversible

Adjustable Speed

Worklight L.E.D



PB L20 BRUSHLESS	X	X	X	1.2395
PBL 2032 PK BRUSHLESS	2 x 2.0Ah	✓	✓	1.2172
PBL 2033 PK BRUSHLESS	2.0 + 4.0Ah	✓	✓	1.2323
PBL 2034 PK BRUSHLESS	2 x 4.0Ah	✓	✓	1.2674
PBL 2035 PK BRUSHLESS	2 x 5.0Ah	✓	✓	1.2242

DRILL / HAMMER DRILL / SCREWDRIVER 18V

PBL 70 BRUSHLESS L20

No load speed	0-400/0-2000	rpm
Impacts	0-7500 / 0-30000	ipm
Chuck Capacity	ø13	mm
Tightening Torque	70	Nm
Settings	20	
Max. wood drilling	ø45	mm
Max. masonry drilling	ø13	mm
Max. steel drilling	ø13	mm
Weight	1.2	kg

BRUSHLESS motor:
Increased performance and service life.

3 Functions

Drill, Screwdriver & Hammer drill.

- Automatic metal chuck with safety lock 13mm.
- Clutch with 20 adjustment points for tightening limit control.
- L.E.D. guide light.
- Included:**
- x2 2.0Ah Batteries
- 2A charger
- HD-PE Case



NEW
Check availability



PBL 70 2022 BRUSHLESS	2 x 2.0Ah	✓	✓	1.3232
-----------------------	-----------	---	---	--------

DRILL / HAMMER DRILL / SCREWDRIVER 18V

PBL 80 P - L20

NEW
Check availability

No load speed	0-500/0-2000	rpm
Impacts	0-7500/0-30000	ipm
Chuck Capacity	1.5 - 13	mm
Tightening Torque	80	Nm
Settings	20+3	
Max. wood drilling	ø50	mm
Max. masonry drilling	ø14	mm
Max. steel drilling	ø16	mm
Weight	1.2	kg



**Motor
BRUSHLESS**



- Drill / Screwdriver / Percussion 18V battery, with a large torque of 80Nm and a powerful BRUSHLESS motor, brushless.
- Automatic metal chuck with 13mm safety lock..
- Clutch with 20 settings + 3 adjustment functions for tightening limit control. Torque limiting clutch, designed to release the gears in case the drill bit jams, thus protecting the tool and the operator.

- 2 mechanical speeds.

Speed / Configuration 1: maximum torque up to 500 rpm for screwdriving, metal drilling and hard wood drilling with large diameter bits.

Speed / Setting 2: minimum torque and maximum speed up to 2000 rpm for drilling materials and soft woods, with small diameter bits, and for hammer drilling construction materials.

- Powerful brushless motor for increased efficiency, significantly reducing heat build-up and considerably increasing motor life and battery life.

- STAYER Li-ion HIGH-TECH, L20 battery with overcharge, battery discharge, overheating and short circuit protection. LED charge indicator.

- Belt clip.

- LED guide light.



Cod.

PBL 80 P - L20	X	X	X	1.2903
PBL 80 P - L2022	2 x 2.0Ah	✓	✓	1.3263
PBL 80 P - L2024	2 x 4.0Ah	✓	✓	1.3264
PBL 80 P - L2025	2 x 5.0Ah	✓	✓	1.3265



DRILL / HAMMER DRILL / SCREWDRIVER 18V

PBL 150 P - L20

NEW
Check availability

No load speed	0-500/0-2100	rpm
Impacts	0-35000	ipm
Chuck Capacity	1.5 - 13	mm
Tightening Torque	150	Nm
Settings	20+3	
Max. wood drilling	ø60	mm
Max. masonry drilling	ø16	mm
Max. steel drilling	ø20	mm
Weight	1.4	kg



**Motor
BRUSHLESS**



- Drill / Screwdriver / Percussion 18V battery, with a large torque of 80Nm and a powerful BRUSHLESS motor, brushless.
- Automatic metal chuck with 13mm safety lock..
- Clutch with 20 settings + 3 adjustment functions for tightening limit control. Torque limiting clutch, designed to release the gears in case the drill bit jams, thus protecting the tool and the operator.

- 2 mechanical speeds for best torque.

Speed / Setting 1: maximum torque up to 500 rpm for screwdriving, metal drilling and hard wood drilling with large diameter bits.

Speed / Setting 2: minimum torque and maximum speed up to 2100 rpm for drilling materials and soft woods, with small diameter bits, and for hammer drilling construction materials.

- Powerful brushless motor for increased efficiency, significantly reducing heat build-up and considerably increasing motor life and battery life.

- STAYER Li-ion HIGH-TECH, L20 battery with overcharge, battery discharge, overheating and short circuit protection. LED charge indicator.

- Belt clip.

- LED guide light..

- Magnet for tips.

- Auxiliary handle.



Cod.

PBL 150 P - L20	X	X	X	1.2904
PBL 150 P - L2022	2 x 2.0Ah	✓	✓	1.2967
PBL 150 P - L2024	2 x 4.0Ah	✓	✓	1.2968
PBL 150 P - L2025	2 x 5.0Ah	✓	✓	1.2969
PBL 150 P - L2026	2 x 6.0Ah	✓	✓	1.3266





IMPACT SCREWDRIVER 18V - 1/4"

IS L20

No load speed	0-2800	rpm
Impacts	0-3600	ipm
Insertion	1/4"	UNF
Tightening Torque	180	Nm
Weight	1.2	kg

- 18 V, 1/4", 180 Nm torque, battery powered impact driver, compatible with L20 RANGE.

- Powerful motor 775
- Aluminum housing
- Reversible.
- Speed regulator
- L.E.D guide light



IS L20	X	X	X	Cod.
IS L2012 Set	1 x 2.0Ah	✓	✓	1.2526
IS L2014 Set	1 x 4.0Ah	✓	✓	1.2527
IS L2022 Set	2 x 2.0Ah	✓	✓	1.2208
IS L2024 Set	2 x 4.0Ah	✓	✓	1.2214



BRUSHLESS IMPACT WRENCH 230 Nm - 18V - 1/4"

IS 230 L20

No load speed	0-1400 / 0-2000 / 0-2700 / 0-3400	rpm
Impacts	0-1400 / 0-2300 / 0-3100 / 0-4000	ipm
Insertion	1/4"	UNF
Tightening Torque	90 / 150 / 180 / 230	Nm
Weight	0.9	kg



IS 230 L20	X	X	X	Cod.
IS 230 L2012	1 x 2.0Ah	✓	✓	1.2996
IS 230 L2022	2 x 2.0Ah	✓	✓	1.2997
IS 230 L2014	1 x 4.0Ah	✓	✓	1.2998
IS 230 L2024	2 x 4.0Ah	✓	✓	1.2999
IS 230 L2025	2 x 5.0Ah	✓	✓	1.3000

- 18 V, 1/4" battery powered impact screwdriver with Brushless motor, torque 230 Nm, 9 working modes, compatible with L20 RANGE.

- 4 settings combining speed, impacts and torque (green color)

- **MODE 1:** 0 - 1400 rpm / 0 - 1400 bpm / 90 Nm
- **MODE 2:** 0 - 2000 rpm / 0 - 2300 bpm / 150 Nm
- **MODE 3:** 0 - 2700 rpm / 0 - 3100 bpm / 180 Nm
- **MODE 4:** 0 - 3400 rpm / 0 - 4000 bpm / 230 Nm

- 3 Tightening Functions (red color)

- **FUNCTION 1 WOOD:** Drilling-Screwing in wood - Starts slowly so that the screw does not slip, and when it detects that the tip is penetrating the wood, it increases the speed.
- **FUNCTION 2 THIN METAL:** Self-tapping screws in thin metal sheets - Starts working at maximum speed, and when it detects that the screw has completely entered, the machine stops automatically.
- **FUNCTION 3 THICK METAL:** Self-tapping screws in thick metal sheets (5 mm) - Starts working at maximum speed to facilitate drilling, and when it detects that the screw has almost completely entered, the speed of the machine will automatically slow down to finish tightening slowly. In this way we prevent the screw from not being tightened properly and from slipping at the start.



- 2 Loosening Functions

- **Continuous mode** (no LED active)
- **Automatic stop mode** (red LED on)
- Variable speed adjustment switch. Reversible in both directions.
- **Self-release bit holder:** Allows a much more comfortable bit change.
- **LED guide light in working area.** Powerful brushless motor for increased efficiency, significantly reducing heat build-up and considerably increasing motor life and battery life.
- **STAYER Li-ion HIGH-TECH, L20** battery with protection against overload, battery discharge, overheating, short circuit.
- **LED charge indicator.**



NEW
Check availability



**SET 2 MACHINES:
DRILL + IMPACT SCREWDRIVER**

PBL80 P L2024 + IS 230

Cod. 1.2906

NEW





Cod.

SET PBL80P L2024 + IS 230	2 x 4.0Ah	✓	✓	1.2906
----------------------------------	-----------	---	---	---------------



BRUSHLESS SCREWDRIVER 18V

DWS L20

No load speed	0-4400	rpm
Insertion	1/4"	UNF
Tightening Torque	4	Nm
Weight	1	kg

- **BRUSHLESS Motor:** higher performance and longer life.
- **Powerful brushless motor** for increased efficiency, significantly reducing heat build-up and considerably increasing motor life and battery life.
- **STAYER Li-ion HIGH-TECH, L20 battery** with protection against overcharge, battery discharge, overheating, short circuit. **LED charge indicator.**
- **Designed for plasterboard panels.**
- Reversible switch with speed control.
- Instantaneous electronic brake when switch is released.
- Head with depth adjustment.
- L.E.D. guide light.



**SPECIAL FOR
DRYWALLS**



Cod.

DWS L20	X	X	X	1.2580
DWS L2012 K	1 x 2.0Ah	✓	✓	1.3335
DWS L2022 K	2 x 2.0Ah	✓	✓	1.2581
DWS L2014 K	1 x 4.0Ah	✓	✓	1.3337
DWS L2024 K	2 x 4.0Ah	✓	✓	1.2680



 **L.E.D.**
 **REVERSIBLE**
 **SCREWDRIVER**
 **ELECTRONIC SPEED CONTROLLER**

ACCESSORY FOR PLASTERBOARD SCREWDRIVER

SCREW FEEDER FOR DWS L20

Cod. 1.3083

- Screw feeder for DWS L20 plasterboard screwdriver.
- Adaptable depth regulator.
- Very light 0.33Kg.
- Length regulator for the screws, allowing to use different sizes from 25mm to 55mm of screw.
- Several positions to improve the user's comfort when screwing.
- Easy and fast screw string placement.



NEW

SCREW DRIVER AND SCREW FEEDER



Cod.

DWS L2012 + Feeder	1 x 2.0Ah	✓	✓	1.3176
DWS L2022 + Feeder	2 x 2.0Ah	✓	✓	1.3177
DWS L2014 + Feeder	1 x 4.0Ah	✓	✓	1.3178
DWS L2024 + Feeder	2 x 4.0Ah	✓	✓	1.3179





PLASTERBOARD CUTTER

DWR L20

No load speed	2600	rpm
Insertion	1/4" - 1/8"	UNF
Weight	0.96	kg

- Cutting saw for drywall.
- Ideal for plasterboard, electrical cutouts in drywall walls and ceilings
- LED guide light.
- Adjustable depth to improve support and control of the cut, depending.
- Suitable for fast and small plasterboard cuts, thanks to its 26,000 rpm.
- Sealed switch with dust protection.
- Soft Start.
- Quick cutter change.
- Lightweight and ergonomic for one-handed operation.
- 1/4" (6.4 mm) and 1/8" (3.2 mm) collets.

NEW
Check availability



COLLET 1/4 Pladur fast cut DWR L20 **12.926**
COLLET 1/8 Pladur clean cut DWR L20 **12.927**

				Cod.
DWR L20	X	X	X	1.3229
DWR L2012 Set	1 x 2.0Ah	✓	✓	1.3230
DWR L2022 Set	2 x 2.0Ah	✓	✓	1.3231

CAULKING GUN 18V

CG L20

Max. feed power	5000	N
Feeding speed	0.7 / 11	mm/s
Max cartridge capacity	310	ml
Weight	2	kg

- Consistent and uniform silicone beads. The tool is specially designed to be adapted to the thickness, stickiness and viscosity of the cartridge used.
- Anti dripping system to avoid stains after stopping the tool.
- 6 levels electronic speed regulator.
- Safety switch lock.
- Power controlled by trigger pressure.
- Anti sliding ergonomic handle.
- Specially meant for long duration tasks with high thickness and viscosity materials.
- Designed for glass work, assemblies, automotive, tiling & work with all types of glass panels.



				Cod.
CG L20	X	X	X	1.2760
CG L2012 Set	1 x 2.0Ah	✓	✓	1.2802
CG L2022 Set	2 x 2.0Ah	✓	✓	1.2803
CG L2014 Set	1 x 4.0Ah	✓	✓	1.2804



SAUSAGE CARTRIDGE

Cod. 1.3040

Dimensions	ø60 x 500	mm
Max. tube capacity	600	ml
Weight	780	gr

- Cartridge to expand the capacity of the CG L20 up to 600 ml.
- Specially designed for large capacity sausages of polyurethane, silicone and other adhesives.
- Easy installation on the tool by replacing the push rod and screwing the cartridge to the gun.



SILICONE GUN AND SAUSAGE CARTRIDGE

			Cod.
CG L2012 + Cartridge	1 x 2.0Ah	✓	1.3167
CG L2022 + Cartridge	2 x 2.0Ah	✓	1.3168
CG L2014 + Cartridge	1 x 4.0Ah	✓	1.3169
CG L2024 + Cartridge	2 x 4.0Ah	✓	1.3170

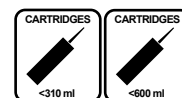

PORCELAIN VIBRATOR 18V
TV L20

NEW
Check availability

Suction cup diameter	130	mm
Maximum capacity	50	kgs
Vibration frequency	6	speeds
Weight	1.9	kg

- **Strong suction force:** 50 kg clamping capacity for tiles and slabs, ceramic, stoneware, porcelain, granite and marble.
- **Suitable for wall tiles, small floor tiles:** for moving and relocating floor and wall tiles, which significantly improves work efficiency
- **One-button vibration, uniform force:** to adjust the vibration frequency to the size of the brick, correct the position of the brick and improve efficiency
- **Non-slip handle:** stable and safe operation.
- Aluminum head.
- Locking clamping button.



	X	X	X	Cod.
TV L20	X	X	X	1.3257
TV L2012 Set	1 x 2.0Ah	✓	✓	1.3258
TV L2022 Set	2 x 2.0Ah	✓	✓	1.3259
TV L2014 Set	1 x 4.0Ah	✓	✓	1.3260
TV L2024 Set	2 x 4.0Ah	✓	✓	1.3261



WEIGHT kg 1.9	PLATE ø130 mm	ELECTRONIC CONTROLLER SPEED 6
----------------------------	-------------------------	---

DUAL MIXER 18V
DM L20

No load speed	0-600 / 0-900	rpm
Insertion	M18	
Upper whisk	ø120	mm
Lower whisk	ø95	mm
Whisk Length	600	mm
Weight	4.5	kg

- **Double whisk with inverse rotation**
- Upper whisk spins rightwise.
- Lower whisk spins leftwise
- 2 Mechanical speeds for better mixing
- Speed regulator



	X	X	X	Cod.
DM L20	X	X	X	1.2233
DM L2012 Set	1 x 2.0Ah	✓	X	1.2529
DM L2022 Set	2 x 2.0Ah	✓	X	1.2234
DM L2024 Set	2 x 4.0Ah	✓	X	1.2235



WHISK DUAL	PAINT	MORTAR	SAFETY SWITCH
-------------------	--------------	---------------	----------------------



RATCHET WRENCH 18V - 3/8" - 1/4"
RW L20

NEW
Check availability

No load speed	0-250	rpm
Insertion	3/8-1/4	"
Tightening torque	60	Nm
Weight	1.3	kg

- Ideal for mechanical and/or automotive fastening work.
- **Adapter for 1/4" wrench.**
- Locking lever.
- **Easy access to spaces.**
- Adjustable trigger for easy tool handling.
- **LED guide light.**
- Rubber coating for better adherence.
- **L20 battery insertion.**
- **Variable speed.**



	X	X	X	Cod.
RW L20	X	X	X	1.3082
RW L2012 Set	1 x 2.0Ah	✓	✓	1.3267
RW L2022 Set	2 x 2.0Ah	✓	✓	1.3268
RW L2014 Set	1 x 4.0Ah	✓	✓	1.3269
RW L2024 Set	2 x 4.0Ah	✓	✓	1.3270

NO LOAD SPEED 0-250 min ⁻¹	MAX TORQUE 60 Nm	INSERTION 3/8"-1/4"	WEIGHT kg 1,3 kg
---	----------------------------	-------------------------------	-------------------------------



IMPACT WRENCH 18V - 1/2"

IW L20

No load speed	0-2300	rpm
Impacts	0-3200	ipm
Insertion	1/2"	UNF
Tightening Torque	100-200-300-400	Nm
Weight	1.9	kg



IW L20	X	X	X	1.2105
IW L2012 Set	1 x 2.0Ah	✓	✓	1.2528
IW L2014 Set	1 x 4.0Ah	✓	✓	1.2458
IW L2022 Set	2 x 2.0Ah	✓	✓	1.2209
IW L2024 Set	2 x 4.0Ah	✓	✓	1.2215
IW L2025 Set	2 x 5.0Ah	✓	✓	1.2500

- Powerful motor 887
- Hard metal planetary gears
- 5 tightening Torque levels: 100 - 200 - 300 - 400 Nm
- Clutch & safety brake
- Reversible.
- Speed regulator
- L.E.D guide light.
- Belt clip.

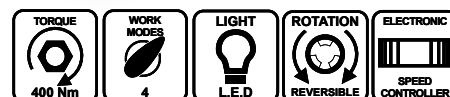

BRUSHLESS IMPACT WRENCH 18V - 1/2"

IWB 550 L20

Cod. 1.2853

No load speed	0-2800	rpm
Impacts	0-3000	ipm
Insertion	1/2"	UNF
Tightening Torque	300-400-550	Nm
Weight	1.47	kg

- BRUSHLESS Motor: higher performance and longer service life

- 3 working levels, with different levels of torque, speed and impacts:

0 - 1800 rpm / 300 Nm / 0 - 1800 ipm.

0 - 2300 rpm / 450 Nm / 0 - 2200 ipm.

0 - 2800 rpm / 550 Nm / 0 - 3000 ipm.



IWB 550 L20	X	X	X	1.2853
IWB 550 L20 Set	1 x 2.0Ah	✓	✓	1.2971
IWB 550 L20 Set	1 x 4.0Ah	✓	✓	1.2973
IWB 550 L20 Set	2 x 2.0Ah	✓	✓	1.2972
IWB 550 L20 Set	2 x 4.0Ah	✓	✓	1.2974
IWB 550 L20 Set	2 x 5.0Ah	✓	✓	1.2975



- 2 loosening modes:

Spot - Max. torque

Continuous

- Max. loosening torque: 750 Nm

- Powerful brushless motor for increased efficiency, significantly reducing heating and significantly increasing motor life and battery life.

- STAYER Li-ion HIGH-TECH, L20 battery with protection against overcharge, battery discharge, overheating, short circuit. LED charge indicator.

- Safety clutch and brake

- Reversible.

- Speed regulator

- Anti-vibration rubber coating

- L.E.D. guide light.

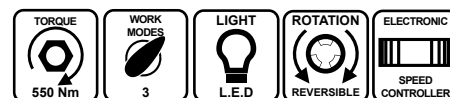

BRUSHLESS IMPACT WRENCH 18V - 1/2"

IWB 750 L20

Cod. 1.2845

No load speed	0-2400	rpm
Impacts	0-2400	ipm
Insertion	1/2"	UNF
Tightening Torque	300-500-750	Nm
Weight	2	kg

- BRUSHLESS Motor: higher performance and longer service life

- 3 working levels, with different levels of torque, speed and impacts:

0 - 1400 rpm / 300 Nm / 0 - 1600 ipm.

0 - 1900 rpm / 500 Nm / 0 - 2000 ipm.

0 - 2400 rpm / 750 Nm / 0 - 2400 ipm.



IWB 750 L20	X	X	X	1.2845
IWB 750 L20 Set	1 x 2.0Ah	✓	✓	1.2976
IWB 750 L20 Set	1 x 4.0Ah	✓	✓	1.2978
IWB 750 L20 Set	2 x 2.0Ah	✓	✓	1.2977
IWB 750 L20 Set	2 x 4.0Ah	✓	✓	1.2979
IWB 750 L20 Set	2 x 5.0Ah	✓	✓	1.2980
IWB 750 L20 Set	2 x 6.0Ah	✓	✓	1.3272



- 2 loosening modes:

Spot - Max. torque

Continuous

- Max. loosening torque: 1000 Nm

- Powerful brushless motor for increased efficiency, significantly reducing heating and significantly increasing motor life and battery life.

- STAYER Li-ion HIGH-TECH, L20 battery with protection against overcharge, battery discharge, overheating, short circuit. LED charge indicator.

- Safety clutch and brake

- Reversible.

- Speed regulator

- Anti-vibration rubber coating

- L.E.D. guide light.

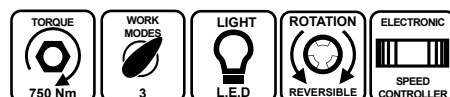

BRUSHLESS IMPACT WRENCH 18V - 1/2"

IWB 1000 L20

NEW
Check availability

No load speed	0-1700	rpm
Impacts	0-2100	ipm
Insertion	1/2"	UNF
Tightening Torque	650-800-1000	Nm
Weight	3.2	kg



- **BRUSHLESS motor** higher performance and longer service life
- 3 working levels, with different degrees of torque, speed and impacts:
 - 0 - 1000 rpm / 650 Nm / 0 - 1200 ipm.
 - 0 - 1200 rpm / 800 Nm / 0 - 1500 ipm.
 - 0 - 1700 rpm / 1000 Nm / 0 - 2100 ipm.
- 2 loosening modes:
 - Spot - Max.Par
 - Continuous
- Max. loosening torque: 1300 Nm

- Powerful brushless motor for increased efficiency, significantly reducing heating and significantly increasing motor life and battery life.
- **STAYER Li-ion HIGH-TECH, L20** battery with protection against overcharge, battery discharge, overheating, short circuit. LED charge indicator.
- Safety clutch and brake
- Reversible.
- Speed regulator
- L.E.D. working light



IWB 1000 L20	X	X	X	1.2791
IWB 1000 L20 Set	2 x 4.0Ah	✓	✓	1.2586
IWB 1000 L20 Set	2 x 5.0Ah	✓	✓	1.2995
IWB 1000 L20 Set	2 x 6.0Ah	✓	✓	1.3276

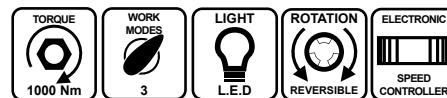

BRUSHLESS IMPACT WRENCH 18V - 3/4"

IWB 1600

NEW
Check availability

No load speed	0-1000 / 0-1400 / 0-1750	rpm
Impacts	1000 / 1800 / 2400	ipm
Insertion	3/4"	UNF
Tightening Torque	900 / 1300 / 1600	Nm
Weight	3.4	kg



- **BRUSHLESS motor:** higher performance and longer life.
- High speed.
- **Maximum loosening torque: 2300 Nm**
- Safety clutch and brake
- Reversible.
- Speed regulator
- L.E.D. guide light.



IWB 1600	2 x 7.5Ah	✓	✓	1.3058
-----------------	-----------	---	---	---------------

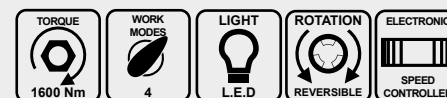

BATTERY AND CHARGER 7.5Ah (NOT COMPATIBLE WITH L20)

BATTERY IWB 1600
Cod. 12.933



CHARGER IWB 1600
Cod. 12.932





ROTARY HAMMER 18V

HDB L20

No load speed	0-1200	rpm
Impacts	0-5300	ipm
Insertion	SDS PLUS	
Impact energy	2.8	J
Max. masonry drilling	ø26	mm
Weight	2.6	kg

- Reversible.
- Adjustable speed
- Auxiliary handle.

- **BRUSHLESS Motor** greater performance & lifespan

4 Functions:

1. **Rotary:** for metal, wood & plastic.
 2. **Rotary with percussion:** for construction materials.
 3. **Chiselling:** for construction materials.
 4. **Vario-lock:** to control the chisel position
- Pneumatic perforation: drills 20 times faster than a similar impact tool.



HDB L20	X	X	X	1.2391
HDB L2014 Set	1 x 4.0Ah	✓	✓	1.2517
HDB L2024 Set	2 x 4.0Ah	✓	✓	1.2417
HDB L2025 Set	2 x 5.0Ah	✓	✓	1.2418
HDB L2026 Set	2 x 6.0Ah	✓	✓	1.3280



ROTARY HAMMER 18V

ROCKY L20

No load speed	0-900	rpm
Impacts	0-5000	ipm
Insertion	SDS PLUS	
Impact energy	1.1	J
Max. masonry drilling	ø16	mm
Max. steel drilling	ø13	mm
Weight	1.2	kg

- **Included**
34 accessories set

2 Functions:

1. **Rotary:** for metal, wood & plastic.
 2. **Rotary with percussion:** for construction materials.
- Reversible.
 - Electronic tightening torque and safety clutch.
 - Rotary and Impact drilling for an optimal performance.
 - L.E.D guide light.



ROCKY L20	X	X	X	X	1.2067
ROCKY L2014 Set	1 x 4.0Ah	✓	X	✓	1.2519
ROCKY L2024 Set	2 x 4.0Ah	✓	X	✓	1.2200
ROCKY L2025 Set	2 x 5.0Ah	✓	X	✓	1.3283



RIVETER GUN

RG L20 BRUSHLESS

Tensile strength	20000	N
Rivet size	2.4 - 3.2 - 4.0 - 5.0	mm
Rivet length	27	mm
Riveting modes	Automatic / manual	
Weight	1.5	kg



NEW
Check availability



RG L20 BRUSHLESS	X	X	X	1.3347
RG L2022 BRUSHLESS	2 x 2.0Ah	✓	X	1.3348
RG L2024 BRUSHLESS	2 x 4.0Ah	✓	X	1.3349
RG L2025 BRUSHLESS	2 x 5.0Ah	✓	X	1.3350

- **BRUSHLESS Motor:** higher performance and longer life.
- **Powerful brushless motor** for increased efficiency, significantly reducing heating and considerably increasing motor life and battery life.
- **STAYER Li-ion HIGH-TECH, L20 battery** with protection against overcharge, battery discharge, overheating, short circuit. LED charge indicator.
- Blind rivets 27 mm long.
- Ergonomic and balanced handle.
- Rivet material: Aluminum, Stainless steel, Steel.
- LED guide light.

ANGLE GRINDER 18V

AGR L20

AGR 125 L20

AGR L20

AGR 125 L20

No load speed	8500	8500	rpm
Disc diameter	ø115	ø125	mm
Insertion	M14	M14	
Weight	1.5	1.5	kg



- Angle grinder 115 / 125 mm with 18V battery.
- **Paddle switch** safety switch. When the switch is activated, an electric braking system stops the disc in less than 2 seconds. This prevents possible accidents should the operator drop the tool.
- **Safety clutch** that reduces the reaction in case of jamming or stopping. This protects the user from being pulled away from the tool and causing injury.
- **Adjustable handle** on both sides and on the head, narrow and ergonomic grip, for greater comfort.
- **STAYER Li-ion HIGH-TECH, L20** battery with overcharge, battery discharge, overheat and short circuit protection. **LED guide light**.
- **Cooling system**, optimal to reduce heating and extend the time of use.

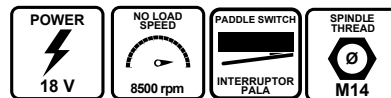

115mm



Cod.

AGR L20	X	X	X	1.2891
AGR L2014	1 x 4.0Ah	✓	✓	1.3089
AGR L2024	2 x 4.0Ah	✓	✓	1.3060
AGR L2015	1 x 5.0Ah	✓	✓	1.3090
AGR L2025	2 x 5.0Ah	✓	✓	1.3091
AGR L2026	2 x 6.0Ah	✓	✓	1.3286

125mm



Cod.

AGR 125 L20	X	X	X	1.3099
AGR 125 L2014	1 x 4.0Ah	✓	✓	1.3100
AGR 125 L2024	2 x 4.0Ah	✓	✓	1.3102
AGR 125 L2015	1 x 5.0Ah	✓	✓	1.3101
AGR 125 L2025	2 x 5.0Ah	✓	✓	1.3103
AGR 125 L2026	2 x 6.0Ah	✓	✓	1.3289

SET 2 MACHINES: BRUSHLESS DRILL / HAMMER DRILL / SCREWDRIVER - 18V

PB L2034 BRUSHLESS

ANGLE GRINDER 18V

AGR L20



2 mechanical speeds

No load speed	0-500/0-2000	rpm
Impacts	0-7500/0-30000	ipm
Chuck Capacity	ø2 - ø13	mm
Tightening Torque	60	Nm
Settings	21 + 3	
Max. wood drilling	ø45	mm
Max. masonry drilling	ø13	mm
Max. steel drilling	ø13	mm
Weight	1.2	kg

- **Powerful brushless motor** for increased efficiency, significantly reducing heating and considerably increasing motor life and battery life.

- **STAYER Li-ion HIGH-TECH, L20** battery with protection against overload, battery discharge, overheating, short circuit. LED charge indicator.

- Belt clip.

- L.E.D. guide light.

- 2 mechanical speeds for better torque.

- Reversible and electronic with microprocessor.

- **BRUSHLESS motor: increased performance and service life**

- **3 Functions:**

Drill, Screwdriver and Hammer.

- Automatic chuck with safety lock.

- Clutch with 21+1+1+1+1 adjustment points for tightening limit control.



Cod.

SET PBL 2034 PK BRUSHLESS + AGR	2 x 4.0Ah	✓	✓	1.3333
--	-----------	---	---	---------------





ULTRALIGHT

BRUSHLESS ANGLE GRINDER 18V

AGBX L20

AGBX 125 L20

AGBX L20 AGBX 125 L20

No load speed	9000	9000	rpm
Disc diameter	ø115	ø125	mm
Insertion	M14	M14	
Weight	1.3	1.3	kg



BRUSHLESS motor: increased performance and service life

- Electronic **constant speed** system
- STAYER Li-ion HIGH-TECH, L20 battery with protection against overloading, battery discharge, overheating, short circuit. LED charge indicator.
- **Braking system** in less than 2 seconds
- Cooling system with protection grids
- Soft start

Cod.

AGBX 125 L2024 Set	2 x 4.0Ah	✓	✓	1.3296
AGBX 125 L2025 Set	2 x 5.0Ah	✓	✓	1.3297

Cod.

AGBX L20	X	X	X	1.3235
AGBX L2014 Set	1 x 4.0Ah	✓	✓	1.3288
AGBX L2015 Set	1 x 5.0Ah	✓	✓	1.3290
AGBX L2024 Set	2 x 4.0Ah	✓	✓	1.3291
AGBX L2025 Set	2 x 5.0Ah	✓	✓	1.3292
AGBX L2026 Set	2 x 6.0Ah	✓	✓	1.3293

BRUSHLESS ANGLE GRINDER 18V

AGB L20

AGB125 L20

AGB L20 AGB 125

No load speed	10000	10000	rpm
Disc size	ø115	ø125	mm
Insertion	M14	M14	
Weight	1.3	1.3	kg



BRUSHLESS motor: increased performance and service life

- Electronic **constant speed** system
- Hand-operated **paddle switch**
- **Powerful brushless motor** for increased efficiency, significantly reducing heating build-up and considerably increasing motor life and battery life.
- STAYER Li-ion HIGH-TECH, L20 battery with protection against overcharge, battery discharge, overheating, short circuit. **LED charge indicator.**
- Narrow ergonomically designed body, allows the grinder to be held with one hand.
- Braking system in less than 2 seconds
- Safety clutch against clogging and jamming
- Cooling system with protective grids
- Auxiliary side handle with 2 positions
- Soft start

Cod.

AGB125 L20	X	X	X	1.2833
AGB125 L2014 Set	1 x 4.0Ah	✓	✓	1.2839
AGB125 L2015 Set	1 x 5.0Ah	✓	✓	1.2840
AGB125 L2024	2 x 4.0Ah	✓	X	1.2841
AGB125 L2025 Set	2 x 5.0Ah	✓	✓	1.2842
AGB125 L2026 Set	2 x 6.0Ah	✓	✓	1.3300

Cod.

AGB L20	X	X	X	1.2386
AGB L 2014	1 x 4.0Ah	✓	X	1.2520
AGB L2014 Set	1 x 4.0Ah	✓	✓	1.2523
AGB L2015 Set	1 x 5.0Ah	✓	✓	1.2521
AGB L2024	2 x 4.0Ah	✓	X	1.2414
AGB L2025 Set	2 x 5.0Ah	✓	✓	1.2415
AGB L2026 Set	2 x 6.0Ah	✓	✓	1.3299

ORBITAL SANDER 18V

LOM L20

No load speed	2000-3500-5000-6500-8000-10000	rpm
Plate size	ø125	mm
Orbit	2.7	mm
Weight	1.1	kg

- Self adhering plate with 8 holes
- Built-in dust extraction system
- 6 levels electronic speed regulator
- Ergonomic design for single hand use
- L.E.D guide light.

Included
Dust collecting bag
x2 Sanding sheets
P120 & P400



				Cod.
LOM L20	X	X	X	1.2069
LOM L2012 Set	1 x 2.0Ah	✓	✓	1.2536
LOM L2022 Set	2 x 2.0Ah	✓	✓	1.2213

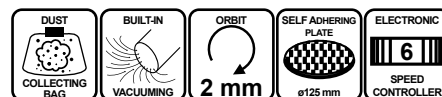

SANDER 18V

DELTA L20

Revolutions per minute	11000	rpm
Plate size	148x100	mm
Sandpaper	150x150x100	mm
Orbit	1.6	mm
Weight	0.85	kg

- Adhesive plate with 15 suction holes.
- Transparent dust collection tank.
- Ergonomic design for one-handed operation.



NEW
Check availability



				Cod.
DELTA L20	X	X	X	1.3302
DELTA L2012 Set	1 x 2.0Ah	✓	✓	1.3303
DELTA L2022 Set	2 x 2.0Ah	✓	✓	1.3304

- Includes
3 sheets of sandpaper.

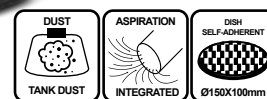

MILLING MACHINE 18V

PR8

No load speed	0-2600	rpm
Plate size	ø125	mm
clamp	6 - 8	
Orbit	2	mm
Weight	1.1	kg

- **BRUSHLESS motor:** increased performance and service life
- Effortless milling of wood edges, grooves and decorative motifs
- Suction adapter for a clean working environment.
- **Powerful brushless motor** for increased efficiency, significantly reducing heating and significantly increasing motor life and battery life.
- **STAYER Li-ion HIGH-TECH, L20** battery with protection against overcharge, battery discharge, overheating, short circuit. LED charge indicator.
- Light and comfortable to use thanks to its compact design and low weight of only 1.1 kg.

PR8 COMPACT L20



				Cod.
PR8 COMPACT L20	X	X	X	1.3246
PR8 COMPACT L20 2012	1 x 2.0Ah	✓	✓	1.3247
PR8 COMPACT L20 2022	2 x 2.0Ah	✓	✓	1.3248
PR8 COMPACT L20 2014	1 x 4.0Ah	✓	✓	1.3249
PR8 COMPACT L20 2024	2 x 4.0Ah	✓	✓	1.3250

PR8 PRO L20



				Cod.
PR8 PRO L20	X	X	X	1.3351
PR8 PRO L20 2012	1 x 2.0Ah	✓	✓	1.3252
PR8 PRO L20 2022	2 x 2.0Ah	✓	✓	1.3253
PR8 PRO L20 2014	1 x 4.0Ah	✓	✓	1.3254
PR8 PRO L20 2024	2 x 4.0Ah	✓	✓	1.3255



Adapter for PR8 COMPACT L20
12.925





RECIPROCATING SAW 18V

SS L20

Saws per minute	0-3000	spm
Saw displacement	22	mm
Max. wood cutting	180	mm
Max. metal profile cutting	100	mm
Max. solid steel cutting	10	mm
Max. aluminum cutting	25	mm
Weight	1.7	kg



- Pendular cut setting
- Quick blade change. Universal insertion
- Cutting depth regulator
- Speed controller trigger
- Safety switch lock
- L.E.D worklight

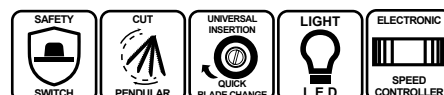

Cod.

				Cod.
SS L20	X	X	X	1.2080
SS L2012 Set	1 x 2.0Ah	✓	✓	1.2531
SS L2014 Set	1 x 4.0Ah	✓	✓	1.2532
SS L2022 Set	2 x 2.0Ah	✓	✓	1.2210
SS L2024 Set	2 x 4.0Ah	✓	✓	1.2216

RECIPROCATING SAW 18V

SSP L20

Saws per minute	0-3100	spm
Saw displacement	28	mm
Max. wood cutting	210	mm
Max. metal profile cutting	110	mm
Max. solid steel cutting	15	mm
Max. aluminum cutting	30	mm
Weight	2.7	kg



- Pendulum adjustment
- Quick blade change. Universal insertion
- Cutting depth regulator
- Speed regulator on switch
- Safety lock
- L.E.D. working light

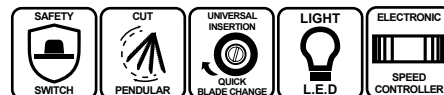

Cod.

				Cod.
SSP L20	X	X	X	1.2892
SSP L2014 Set	1 x 4.0Ah	✓	✓	1.3003
SSP L2022 Set	2 x 2.0Ah	✓	✓	1.3002
SSP L2024 Set	2 x 4.0Ah	✓	✓	1.3004
SSP L2025 Set	2 x 5.0Ah	✓	✓	1.3005

JIG SAW 18V

S L20

No load speed	0-2700	rpm
Saw displacement	20	mm
Max. wood cutting	90	mm
Max. steel cutting	8	mm
Max. aluminum cutting	12	mm
Tilted cut	0-45	°
Weight	1.7	kg

- Powerful motor 785
- Pendular cut setting with 4 positions
- Quick blade change. T insertion
- Aluminum base
- Speed regulator on the trigger
- Safety switch lock
- L.E.D guide light.
- Built-in blower
- Ready for coupling with an external vacuum cleaner



- Included
Lateral guide

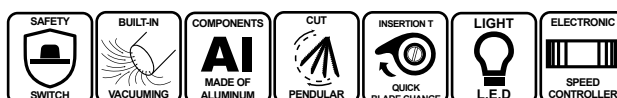

Cod.

				Cod.
S L20	X	X	X	1.2136
S L2012 Set	1 x 2.0Ah	✓	✓	1.2535
S L2022 Set	2 x 2.0Ah	✓	✓	1.2211
S L2024 Set	2 x 4.0Ah	✓	✓	1.2217

CIRCULAR SAW 18V

CP L20

No load speed	4200	rpm
Disc size	ø165 x 20	mm
Max 90° cutting capacity	54	mm
Max 45° cutting capacity	35	mm
Weight	3.2	kg

- Powerful motor 785
- Laser cutting guide
- Aluminum base
- Cutting depth regulator
- Safety switch lock
- Ready for coupling with an external vacuum cleaner

- Included
Lateral guide



				Cod.
CP L20	X	X	X	1.2232
CP L2012	1 x 2.0Ah	✓	X	1.2659
CP L2012 Set	1 x 2.0Ah	✓	✓	1.2533
CP L2014 Set	1 x 4.0Ah	✓	✓	1.2534
CP L2022 Set	2 x 2.0Ah	✓	✓	1.2236
CP L2024 Set	2 x 4.0Ah	✓	✓	1.2419

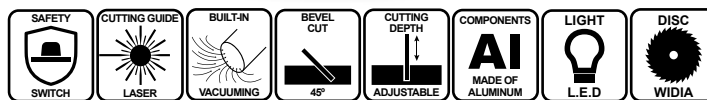

OSCILLATING MULTI TOOL 18V

MULTI L20

No load speed	5000-20000	rpm
Oscillation angle	3	°
Weight	1.1	kg

- Powerful motor 775
- 6 levels electronic speed regulator
- Quick accessory change with no tools
- L.E.D guide light
- Auxiliary handle



- Included
Sanding papers + Delta Plate + Scraper blade +Plunging saw & Semicircular saw

				Cod.
MULTI L20	X	X	X	1.2079
MULTI L2012 Set	1 x 2.0Ah	✓	✓	1.2530
MULTI L2022 Set	2 x 2.0Ah	✓	✓	1.2212

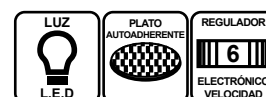

NAILER STAPPLER 18V

NS L20

Impacts per minute	30	ipm
T Nails	15-32	mm
Staples	15-25	mm
Weight	1.8	kg

- Powerful motor 750
- Suitable for "T" Nails from ø15 to 32 mm & staples from 15 to 25 mm.
- Specially designed for upholstery and wood working
- Pressure regulator
- Precision head with security sensor
- L.E.D guide light



			Cod.	Accessories	Cod.
NS L20	X	X	1.2642	Caja Clavos Longitud 15mm 1000pcs	12.889
NS L2012	1 x 2.0Ah	✓	1.2643	Caja Clavos Longitud 32mm 1000pcs	12.890
NS L2022	2 x 2.0Ah	✓	1.3301	Caja Grapas Profundidad 15mm 1000pcs	12.891

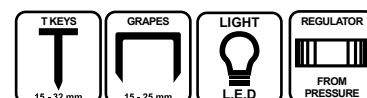



BRANCH PRUNER 18V

BPB 32 L20 BRUSHLESS

Max cutting diameter	ø32	mm
Cuts per second	1.4	s
Weight	0.95	kg

- Automatic branch pruner specially designed for gardening, agriculture, pruning vineyards and fruit trees.
- Double safety system.
- Powerful brushless motor for increased efficiency, significantly reducing heating and considerably increasing motor life and battery life.
- STAYER Li-ion HIGH-TECH, L20 battery with protection against overload, battery discharge, overheating, short circuit. LED charge indicator.
- On/Off switch.

- Included

Lubricant
x2 Service keys



				Cod.
BPB 32 L20	X	X	X	1.2759
BPB 32 L2012 Set	1 x 2.0Ah	✓	✓	1.2805
BPB 32 L2014 Set	1 x 4.0Ah	✓	✓	1.2807
BPB 32 L2022 Set	2 x 2.0Ah	✓	✓	1.2806
BPB 32 L2024 Set	2 x 4.0Ah	✓	✓	1.2808



- Trigger with safety lock.
- Automatic safety lock if the tool remains on for a long time without being used, or if a battery is inserted and suddenly tries to activate.
- Ergonomic non-slip handle.
- Particularly suitable for long-lasting tasks.

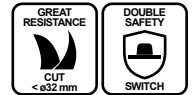

BRANCH PRUNER 18V

BPB40 AGRO L20 BRUSHLESS

Max cutting diameter	ø40	mm
Cuts per second	-	s
Weight	0.96	kg

- Automatic branch pruner specially designed for gardening, agriculture, vineyard and fruit tree pruning.
- Double safety system
- On/off switch.
- Trigger with safety lock.
- Automatic safety lock if the tool remains on for a long time without being used, or if a battery is inserted and suddenly tries to activate.
- Ergonomic non-slip handle.
- Particularly suitable for long-lasting tasks.



				Cod.
BPB 40 L20	X	X	X	1.2992
BPB 40 L2012 Set	1 x 2.0Ah	✓	✓	1.3006
BPB 40 L2014 Set	1 x 4.0Ah	✓	✓	1.3007
BPB 40 L2022 Set	2 x 2.0Ah	✓	✓	1.3008
BPB 40 L2024 Set	2 x 4.0Ah	✓	✓	1.3009



NEW

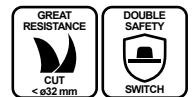

EXTENSION

Extension for branch pruner and battery-powered mini saw.
Ideal for cutting branches easily

NEW



MINI CHAIN SAW 18V

MINI OLMO L20

No load speed	0 - 5400	rpm
Cutting speed	8	m/s
Chain length	10	cm
Max cutting diameter	ø10	cm
Weight	1.35	kg

- Mini chain saw specially designed for gardening, agriculture, vine yard and pruit tree pruning.
- Specially designed to be used with one hand.
- Power controlled by trigger pressure.
- Safety switch lock.
- Anti sliding ergonomic handle.
- Specially meant for long duration tasks.

- Included

Lubricant
x2 Service keys



	X	X	X	Cod.
MINI OLMO L20	X	X	X	1.2794
MINI OLMO L2012 Set	1 x 2.0Ah	✓	✓	1.2809
MINI OLMO L2014 Set	1 x 4.0Ah	✓	✓	1.2811
MINI OLMO L2022 Set	2 x 2.0Ah	✓	✓	1.2810
MINI OLMO L2024 Set	2 x 4.0Ah	✓	✓	1.2812
MINI OLMO L2015 Set	1 x 5.0Ah	✓	✓	1.3305

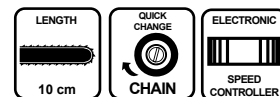

MINI CHAIN SAW 18V

MINI OLMO B L20 (Manual cooling)

No load speed	4.7	m/s
Cutting speed	15	cm
Chain length	ø10	cm
Max cutting diameter	1.54	kg
Weight	30	ml

- Mini chain saw specially designed for gardening, agriculture, vine yard and pruit tree pruning.
- Specially designed to be used with one hand.
- Quick change chain system for smooth and uninterrupted work.
- Trigger with pressure-controlled speed regulator to adapt to all types of tasks.
- Switch with safety lock to avoid accidents due to unintentional operation.
- Light and functional design especially suitable for long duration tasks, reducing operator fatigue..



	X	X	X	Cod.
MINI OLMO BL20	X	X	X	1.2991
MINI OLMO B L2012 Set	1 x 2.0Ah	✓	✓	1.3010
MINI OLMO B L2014 Set	1 x 4.0Ah	✓	✓	1.3011
MINI OLMO B L2022 Set	2 x 2.0Ah	✓	✓	1.3012
MINI OLMO B L2024 Set	2 x 4.0Ah	✓	✓	1.3013
MINI OLMO B L2015 Set	1 x 5.0Ah	✓	✓	1.3306

Special chain for faster cutting speed

NEW

Tilting head 32

Lubrication tank



Hand pump

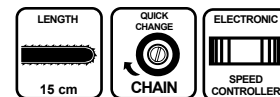

EXTENSION

Extension for branch pruner and battery-powered mini saw. Ideal for cutting branches easily



NEW



CHAIN SAW 18V OLMO 250 L20

Power	400	W
No load speed	0 - 3800	rpm
Chain length	250 / 300	mm
Max. cutting diameter	10	cm
Weight	2.9	kg

NEW
Check availability



- Saw specially designed for gardening, agriculture and fruit trees.
- Adjustable speed by pressing the trigger.
- Trigger with safety lock.

				Cod.
OLMO 250 L20	X	X	X	1.3239
OLMO 250 L2014 Set	1 x 4.0Ah	✓	✓	1.3240
OLMO 250 L2024 Set	2 x 4.0Ah	✓	✓	1.3241
OLMO 250 L2015 Set	1 x 5.0Ah	✓	✓	1.3242
OLMO 250 L2025 Set	2 x 5.0Ah	✓	✓	1.3243
OLMO 250 L2016 Set	1 x 6.0Ah	✓	✓	1.3244
OLMO 250 L2026 Set	2 x 6.0Ah	✓	✓	1.3245

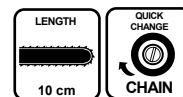

HEDGE TRIMMER 18V ROSE L20

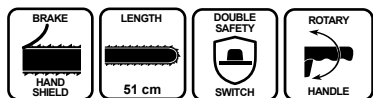
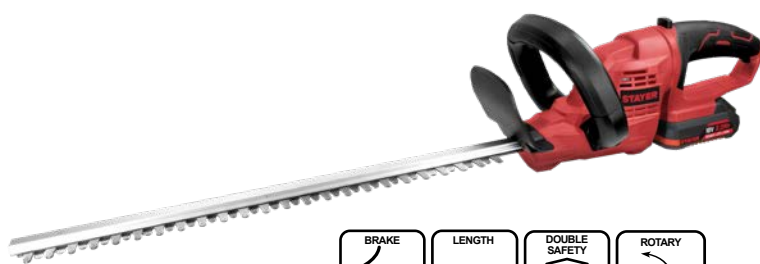

No load speed	2400	rpm
Teeth spacing	15	mm
Cutting length	510	mm
Rotary handle	0-45-90	°
Weight	2.25	kg

- Double sawing blade.
- Double safety switch
- Hand shield
- 5 positions rotary handle.

				Cod.
ROSE L20	X	X	X	1.2137
ROSE L2012 Set	1 x 2.0Ah	✓	X	1.2538
ROSE L2022 Set	2 x 2.0Ah	✓	X	1.2238
ROSE L2024 Set	2 x 4.0Ah	✓	X	1.3307

GRASS CUTTER 18V GRASS CUTTER L20

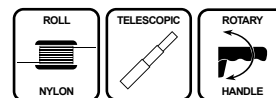

Cutting diameter	ø254	mm
Wire thickness	ø1.6	mm
Roll length	3	m
Weight	2	kg

- Telescopic grass cutter with nylon thread for gardening
- Aluminum structure.
- Double safety switch with power controller.
- Automatic thread feeding system.
- 180° rotary handle.
- Telescopic height to adapt to every user (1 - 1.36m).

				Cod.
GRASS CUTTER L20	X	X	X	1.2761
GRASS C L2022 Set	2 x 2.0Ah	✓	✓	1.2815
GRASS C L2024 Set	2 x 4.0Ah	✓	✓	1.2816

TELESCOPIC HEDGE TRIMMER / PRUNER 18V

MULTI GARDEN CUTTER L20

CHAIN SAW

Cutting speed	8	m/s
Tooth spacing	3/8"	
Bar length	20	cm
Max. Cutting capacity	20	cm
Weight	2.1	kg

HEDGE TRIMMER

No load speed	1300	spm
Bar length	43	cm
Weight	1.8	kg

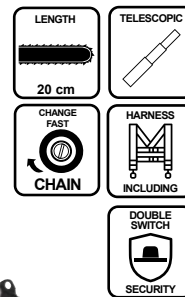

- Telescopic pruner with chainsaw and hedge trimmer functions.
- Easily interchangeable heads for smooth, uninterrupted work.
- Ergonomic non-slip handles for long work.



MGC L20	X	X	X	1.2795
MGC L2022 Set	2 x 2.0Ah	✓	✓	1.2813
MGC L2024 Set	2 x 4.0Ah	✓	✓	1.2814

BLOWER 18V

VENTO L20

No load speed	12000	rpm
Air speed	190	km/h
Noise level	85	dB-w(A)
Weight	1.75	kg

- Powerful constant service motor RS-7855.
- Detachable tube
- 60 cm tube
- Air flow of 68m3/h
- Anti sliding handle
- Ergonomic design



Cod.

VENTO L20	X	X	X	1.2138
VENTO L2012 Set	1 x 2.0Ah	✓	X	1.2537
VENTO L2022 Set	2 x 2.0Ah	✓	X	1.2237

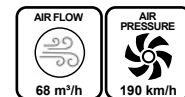

SPRAYER 18V

SP L20

Max. working pressure	4	Bar
Flow	> 0.8	L/min
Tank capacity	15	L
Spears length	800	mm
Weight	4.6	kg

- Sprayer for low viscosity liquids. specially designed for gardening and horticulture.
- Flow system with constant and flashing spraying for different pesticides and liquids.
- Double back support for comfortable long tasks
- Insulated battery housing to avoid any kind of dampening.

BATTERY HOUSING



SP L20	X	X	X	1.2762
SP L2014 Set	1 x 4.0Ah	✓	X	1.2820
SP L2015 Set	1 x 5.0Ah	✓	X	1.2819
SP L2022 Set	2 x 2.0Ah	✓	X	1.2817
SP L2024 Set	2 x 4.0Ah	✓	X	1.2818



BLOWER 36V

VENTO 36V L20

No load speed	0-20000	rpm
Air speed	160	km/h
Noise level	95	dB-w(A)
Air flow rate	470-650-720	m³/h
Weight	2.4	kg



- Powerful constant service motor 897.
- Double battery insertion to reach 36V for maximum performance.
- The tool requires 2 matching batteries with the same amps and charge level
- Turbo feature to boost the tool's airflow for 2 seconds- Con sistema de Boost Mode.
- Easily removable tube
- Double switch to prevent unintentional operation
- Non-slip handle
- Ergonomic design
- Shoulder carrying strap.

				Cod.
VENTO 36V L20	X	X	X	1.2763
VENTO 36V L2024 Set	2 x 4.0Ah	✓	✓	1.2822
VENTO 36V L2025 Set	2 x 5.0Ah	✓	✓	1.2823
VENTO 36V L2026 Set	2 x 6.0Ah	✓	✓	1.3312

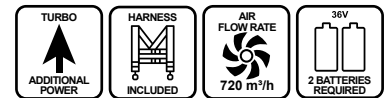

GRASS CUTTER 36V

BRUSH CUTTER 36V L20 BRUSHLESS

No load speed	0 - 7100	rpm
Thread cutting diameter	ø350	mm
Wire thickness	ø2	mm
Disc size	ø250 x 2.5	mm
Weight	4	kg



- Telescopic brushcutter with wire and disc for cutting grass, weeds and bushes.
- High resistance aluminum structure.
- Double safety trigger with electronic speed regulator by pressure.
- Powerful brushless motor for increased efficiency, significantly reducing heat build-up and considerably increasing motor life and battery life.
- STAYER Li-ion HIGH-TECH, L20 battery with protection against overcharge, battery discharge, overheating, short circuit. LED charge indicator.
- Automatic wire feeding system.
- Double 180° rotating handle to suit all types of work.
- Telescopic handle to adapt to the user's height. 2 extendable tubes.

				Cod.
BC 36V L20	X	X	X	1.2764
BC 36V L2024 Set	2 x 4.0Ah	✓	✓	1.2825
BC 36V L2025 Set	2 x 5.0Ah	✓	✓	1.2826
BC 36V L2026 Set	2 x 6.0Ah	✓	✓	1.3313

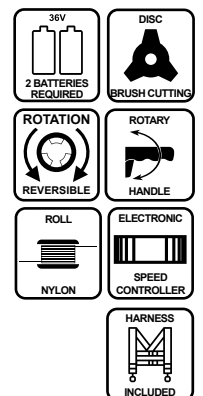

FLASH LIGHT L20

FL 18V L20

Cod. 1.3106

LED power	21	W
Luminous intensity	2500	lm
Battery life	3-6	h
Illumination modes	3	
Weight	0.9	Kg

NEW
Check availability

- Flashlight with 3.7V battery, with light capacity equivalent to 21W LED.
- Different lighting modes with different powers to adapt to all kinds of situations and needs:
- Hanging hook, possibility to use with tripod, tripod.
- STAYER Li-ion HIGH-TECH, L20 battery with overcharge, battery discharge, overheat and short-circuit protection.
- 3 to 6 hours of uninterrupted light depending on the type of lighting chosen.
- Particularly flat design for wall mounting indoors and outdoors. indoors and outdoors.
- IK07 and IP54 protection, dust-tight against dust. dust-tight



				Cod.
FL 18V L20	X	X	X	1.3106
FL 18V L2012 Set	1 x 2.0Ah	✓	✓	1.3308
FL 18V L2022 Set	2 x 2.0Ah	✓	✓	1.3309
FL 18V L2014 Set	1 x 4.0Ah	✓	✓	1.3310
FL 18V L2024 Set	2 x 4.0Ah	✓	✓	1.3311

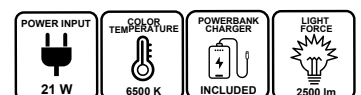

L20 SERIES BATTERIES - 18V

- 2.0 Ah** - Lithium batteries for STAYER L20 SERIES
Cod. 12.575 - Protected against: Overcharge, discharge, overheating & shortcuts
- 4.0 Ah** - Battery level indicator
Cod. 12.577
- 5.0 Ah**
Cod. 12.589
- 6.0 Ah**
Cod. 12.858

2.0Ah Battery

1 row with 5 lithium cells connected in line.
Voltage = 5 cells x 3.6 V/cell = 18 V
Amps = 2.0 Ah

4.0Ah Battery

2 rows connected in parallel containing 5 Lithium cells each connected in line (for a total of 10 cells).
Voltage = 5 cells x 3.6 V/cell = 18 V
Amps = 2.0 Ah/row x 2 Rows = 4.0 Ah

5.0Ah Battery

2 rows connected in parallel containing 5 Lithium cells each connected in line (for a total of 10 cells).
Lithium INR 1865 25 R
Voltage = 5 cells x 3.6 V/cell = 18 V
Amps = 2.5 Ah/row x 2 Rows = 5.0 Ah

6.0Ah Battery

3 rows connected in parallel containing 5 Lithium cells each connected in line (for a total of 15 cells).
Lithium INR 1865 25 R
Voltage = 5 cells x 3.6 V/cell = 18 V
Amps = 2 Ah/row x 3 Rows = 6.0 Ah



L20 BATTERY CHARGERS 18V

- 2.0 A** - Charger for batteries compatible with STAYER L20 SERIES.
Cod. 12.576 Intelligent charger with 2 lights to show the battery charge level.
- 4.0 - 5.0 A** - Protection against overcharge and overheat, increasing the battery lifespan.
Cod. 12.578



L20 CHARGERS 18V

- 2.0 A - 6.0 A**
Cod. 12.916
- Charger compatible with all STAYER L20 range.
Integrated fan.
Amperage sensing.



L20 INTELLIGENT CHARGER 18V

- 2.0 - 8.0 A**
Cod. 12.859
- Charger for batteries compatible with STAYER L20 SERIES.
- Suitable for batteries ranging from 2.0 to 8.0 Ah.
- The charger adapts its current to the connected battery amperage.
- Digital display for maximum battery level control.
- Protection against overcharge and overheat, increasing the battery lifespan.





L20 SERIES STAND



CARRY BAGS & TROLLEYS

INJECTION CARRY CASE

Cod. 12.906

USB BACKPACK

Cod. 1.5939

MULTI SETS BAG

Cod. 1.2393

MAX OPENING BAG

Cod. 1.1944

TROLLEY

Cod. 1.2508



DRILL / HAMMER DRILL / SCREWDRIVER 12V

PBL 122 DPK

Cod. 1.2990

PBL 122 DK

Cod. 1.2989

	PBL 122 DPK		PBL 122 DK	
Battery voltage - Lithium	12	V	12	V
Battery capacity	2.0	Ah	2.0	Ah
No load speed	0-350/0-1350	rpm	0-350/0-1350	rpm
Impacts	0-21000	ipm	-	
Chuck insertion	3/8"	UNF	3/8"	UNF
Max. screw diameter	ø10	mm	ø10	mm
Tightening Torque	32	Nm	32	Nm
Settings	25 + 2		18 + 2	
Weight	0.9	kg	0.9	kg

- 2 Functions: Screwdriver and Hammer Drill.

- 2 mechanical speeds.
- Electronic speed control on the trigger.
- L.E.D. guide light.
- Reversible direction of rotation.

Includes:

- Injection Case
- 2.0 Ah charger
- x2 batteries 2.0 Ah



PBL 122 DPK

PBL 122 DK



SET OF 2 MACHINES 12V

PBL 122 DPK + ISL 122 D

Cod. 1.3136

ISL 122 D

	ISL 122 D	
Battery voltage - Lithium	12	V
Battery capacity	2.0	Ah
No load speed	0-2400	rpm
Impacts	0-3000	ipm
Chuck insertion	1/4"	UNF
Tightening Torque	100	Nm
Weight	0.9	kg

- Impact Screwdriver with aluminum gearbox

- 1/4" hexagonal insert for screwdriver bits.
- Electronic speed control on trigger.
- L.E.D. light indicator in the working area.
- Reversible direction of rotation.

Includes:

- HD-PE case
- 2.0 Ah charger
- x2 batteries 2.0Ah
- Set of bits and wrenches



PBL 122 DPK

ISL 122 DK

NEW
Check availability

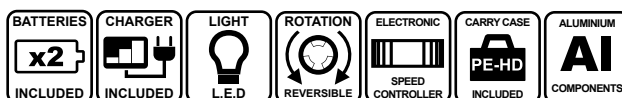



DRILL / HAMMER DRILL / SCREWDRIVER 12V

PBL 122 CPK

Cod. 1.2055

Battery voltage - Lithium	12	V
Battery capacity	2.0	Ah
No load speed	0-400/0-1400	rpm
Impacts	0-21000	ipm
Chuck insertion	3/8"	UNF
Max. screw diameter	ø10	mm
Tightening Torque	28	Nm
Settings	18 + 2	
Weight	0.9	kg

- 2 Functions: Screwdriver & Hammer drill
- 2 Mechanical speeds for enhanced power & speed.
- Power controlled by trigger pressure.
- L.E.D guide light
- Reversible rotation.

Included:

- HD-PE Carry Case
- Charger 2.0 Ah
- x2 Batteries 2.0 Ah



COMPATIBLE
WITH **SS L12**
SS 122 K
ISL 112C



RECIPROCATING SAW 12V

SS L12

Cod. 1.2549

SS 122 K

Cod. 1.2548



COMPATIBLE
WITH **PBL 122 CPK**
ISL 122 C

Battery voltage - Lithium	12	V
Battery capacity	2.0	Ah
No load speed	0-3000	rpm
saw displacement	13	mm
Max. wood cutting	150	mm
Max. metal profile cutting	70	mm
Max pipe cutting	100	mm
Weight	1	kg

- **Specially suited for one hand use**
- Designed for plumbing & pruning: wood, metal sheets & metal pipes, drywall, PVC pipes, branches & logs.
- L.E.D guide light.
- Power controlled by trigger pressure.
- Quick blade change. Universal insertion

SS 122 K:

- HD-PE Carry Case
- Charger 2.0 Ah
- x2 Batteries 2.0 Ah

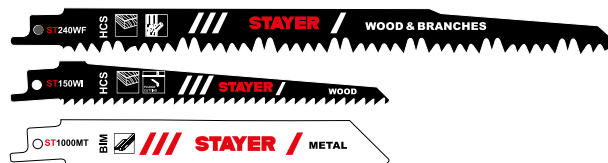

- Included:**
- x1 Pruning saw, x1 Wood saw, x1 Metal saw



SCREWDRIVER 3.6V

BL 50 CK

Cod. 1.2082

Battery voltage - Lithium	3.6	V
Battery capacity	1.3	Ah
No load speed	200	rpm
Chuck Capacity	1/4"	UNF
Tightening Torque	4	Nm
Max. screw diameter	ø8	mm
Settings	7	
Weight	0.3	kg

- Screwdriver with 2 workmodes: die & gun
- Built-in battery
- 10 Screwdriving settings + 1 drilling mode
- L.E.D lamp.
- Reversible.

Included:

- x1 Charger
- 44 Accessories carry case:
- 32 Screwdriver bits
- 8 Socket wrenches
- 2 Metal bits
- 2 Adaptadors 1/4"

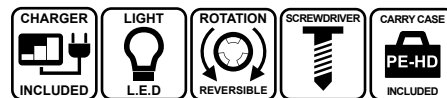

LED LAMP 3.6V

FL 700

Cod. 1.3032

Lithium battery voltage	3.7	V
Battery capacity	4.4	Ah
LED power	3-7	W
Luminous intensity	250-700	lm
Battery life	3-6	h
Charging port	USB-C	
Lighting modes	3	
Weight	460	g

- Magnet to stick it to shelves and scaffolding
- Hook to hang it from shelves
- USB-C port to use it as a mobile charger or power bank.
- Between 3 and 6 hours of uninterrupted light depending on the type of lighting chosen.
- Light and compact design of 112 x 104 x 52 mm and 460g.

NEW

- Flashlight with integrated 3.7V battery, with light capacity equivalent to 7W LED, with USB port to charge mobile phones.
- Different lighting modes with different powers to adapt to all kinds of situations and needs:
 - Concentrated lighting mode 3W
 - Total area lighting mode 7W
 - Standard area lighting mode 3W
- Rotative and foldable multifunction support that allows the spotlight to be used in various ways:
 - Handle to carry it by hand
 - Tripod to place it on flat surfaces



CHARGER BL 50 CK - 3.6V

CHARGER 1.3 A

Cod. 8293.390



CHARGER & BATTERY - 12V

BATTERY 2.0 Ah

Cod. 12.573

CHARGER 2.0 A

Cod. 12.574

Compatible with the entire range
PBL 122 CPK / ISL 122 C/ SS L12



CHARGER & BATTERY - 12V

BATTERY 2.0 Ah

Cod. 12.899

CHARGER 2.0 A

Cod. 12.900

Compatible with all the L12 Series
PBL 122 D-DPK / ISL 122 D





DRILLS

DRILLS

SCREWDRIVER

384 B

Cod. 1.6008

Power	600	W
No load speed	0 - 4500	rpm
Insertion	1/4"	UNF
Max. Self-tapping screws	N.14	ISO
Max. metric screws	ø8	M
Weight	1.8	kg

- Electric screwdriver INSERTION 1/4" UNF
- Specially designed for drywall pannels
- Depth screwing regulator on the head.
- Power controlled by trigger pressure
- Reversible with lever located over the trigger.
- Ergonomic anti sliding handle



DRILL

TM 6 BA

Cod. 1.431

Power	400	W
No load speed	0 - 3000	rpm
Insertion	3/8" x 24	UNF
Chuck Capacity	ø1.5 - 6	mm
Weight	1.1	kg

- No impacts drill
- Compact and lightweight design for wood & drywall
- Keyless chuck
- Power controlled by trigger pressure
- Reversible with lever located over the trigger.



DRILL

TM 10 CA

Cod. 1.1369

Power	450	W
No load speed	0 - 3000	rpm
Insertion	3/8" x 24	UNF
Chuck Capacity	ø1.3 - 10	mm
Weight	1.3	kg

- No impacts drill
- Compact and lightweight design for wood & drywall
- Keyless chuck
- Speed regulator located on the trigger
- Reversible with lever located over the trigger.
- Anti sliding ergonomic handle
- Belt clip.





HAMMER DRILL

TM 710 BA

Cod. 1.1977

TM 710 BAK

Cod. 1.1978

Power	710	W
No load speed	0 - 2800	rpm
Impacts	0 - 44800	ipm
Chuck Capacity	ø2 - 13	mm
Insertion	1/2" x 20	UNF
Max. wood drilling	ø25	mm
Max. steel drilling	ø13	mm
Max. masonry drilling	ø13	mm
Weight	1.9	kg

- Drill with 2 functions: drill & impact drill

- Keyless chuck
- Speed regulator located on the trigger
- Reversible with button located over the trigger.
- Anti sliding ergonomic handle

Included:
- Auxiliary lateral handle
- Depth regulator

TM 710 BAK
Included:
- HD-PE Carry Case

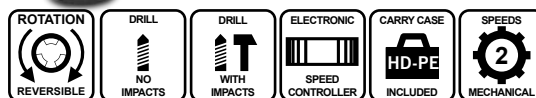

HAMMER DRILL

TM 750 A

Cod. 1.5447

TM 750 AK

Cod. 1.5449

Power	750	W
No load speed	0 - 3000	rpm
Impacts	0 - 45000	ipm
Chuck Capacity	ø1.5 - 13	mm
Insertion	1/2" x 20	UNF
Max. wood drilling	ø28	mm
Max. steel drilling	ø13	mm
Max. masonry drilling	ø13	mm
Weight	2.3	kg

- Drill with 2 functions: drill & impact drill

- Keyless chuck
- Speed regulator located on the trigger
- Reversible with lever located over the trigger.
- Anti sliding ergonomic handle

Included:
- Auxiliary lateral handle
- Depth regulator

TM 750 AK
Included:
- HD-PE Carry Case

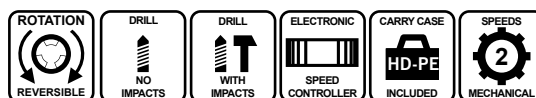

HAMMER DRILL

TM 851 BA

Cod. 1.2755

TM 851 BAK

Cod. 1.2684

Power	850	W
No load speed	0 - 3000	rpm
Impacts	0 - 48000	ipm
Chuck Capacity	ø1.5 - 13	mm
Insertion	1/2" x 20	UNF
Max. wood drilling	ø28	mm
Max. steel drilling	ø13	mm
Max. masonry drilling	ø16	mm
Weight	2.4	kg

- Drill with 2 functions: drill & impact drill

- Aluminum gearbox
- Metal keyless chuck
- Speed regulator located on the trigger
- Reversible with button located over the trigger.
- Anti sliding ergonomic handle

TM 851 BAK
Included:
- HD-PE Carry Case



TALADRO PERCUTOR

TM 950 AK

Cod. 1.1516

Power	950	W
No load speed	0 - 10000/ 0 - 3000	rpm
Impacts	0 - 16000/0 - 44800	ipm
Chuck Capacity	ø1.5 - 13	mm
Insertion	1/2" x 20	UNF
Max. wood drilling	ø30	mm
Max. steel drilling	ø13	mm
Max. masonry drilling	ø16	mm
Weight	3	kg



Included:
 - Auxiliary lateral handle
 - Depth regulator
 - HD-PE Carry Case

- Drill with 2 functions: drill & impact drill
- Aluminum gearbox with 2 Mechanical speeds
- Specially suited for metal at low rpm & construction at max rpm
- Metal keyless safety chuck
- Speed regulator located on the trigger. Reversible rotation

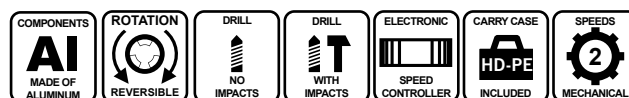

HAMMER DRILL

TM 1100

Cod. 1.1735

Power	1100	W
No load speed	0 - 900/ 0 - 2500	rpm
Impacts	0 - 14400/0 - 40000	ipm
Chuck Capacity	ø16	mm
Insertion	5/8" x 16	UNF
Max. wood drilling	ø32	mm
Max. steel drilling	ø16	mm
Max. masonry drilling	ø16	mm
Weight	3.5	kg



- Drill with 2 functions: drill & impact drill
- Aluminum gearbox with 2 Mechanical speeds
- ø16 mm key chuck.
- Speed regulator located on the trigger. Reversible rotation

Included:
 - Auxiliary lateral handle
 - Depth regulator

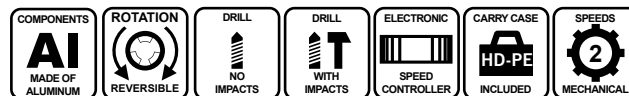

FOR THE TOUGHEST JOBS





HAMMERS

ROTARY HAMMER SDS-PLUS

HD 26 BK

Cod. 1.1418

Power	800	W
No load speed	0 - 1200	rpm
Impacts	0 - 5300	ipm
Impact energy	2.8	J
Insertion	SDS-PLUS	
Max. wood drilling	ø30	mm
Max. steel drilling	ø13	mm
Max. masonry drilling	ø26	mm
Max. core drilling	ø60	mm
Weight	2.8	kg

- Hammer with 3 Functions

- 1- **Rotary:** for metal, wood & plastic
- 2- **Rotary with percussion** for construction materials
- 3- **Chiseller** for construction materials

- Vario - lock to adjust the chisel position

- Reversible by stator.
- Motor with Soft Start & safety clutch



- For concrete and masonry anchoring ø4-26 mm (optimal ø4-12 mm.)

- Included:**
- Auxiliary lateral handle
 - Depth regulator
 - HD-PE Carry Case



ROTARY HAMMER SDS-PLUS

HD 27 CK

Cod. 1.1967

Power	800	W
No load speed	0 - 1300	rpm
Impacts	0 - 5500	ipm
Impact energy	2.8	J
Insertion	SDS-PLUS	
Max. wood drilling	ø30	mm
Max. steel drilling	ø13	mm
Max. masonry drilling	ø26	mm
Max. core drilling	ø68	mm
Weight	2.8	kg

- Hammer with 3 Functions

- 1- **Rotary:** for metal, wood & plastic
- 2- **Rotary with percussion** for construction materials
- 3- **Chiseller** for construction materials

- Vario - lock to adjust the chisel position

- Reversible by lever.
- Motor with safety clutch



- For concrete and masonry anchoring ø4-28 mm (optimal ø4-12 mm.)

- Included:**
- Auxiliary lateral handle
 - Depth regulator
 - HD-PE Carry Case



ROTARY HAMMER SDS-PLUS

HD 3 CK

Cod. 1.2314

Power	1050	W
No load speed	0 - 1100	rpm
Impacts	0 - 4600	ipm
Impact energy	5	J
Insertion	SDS-PLUS	
Max. wood drilling	ø32	mm
Max. steel drilling	ø13	mm
Max. masonry drilling	ø26	mm
Max. core drilling	ø60	mm
Weight	3.5	kg

- Hammer with 4 Functions

- 1- **Rotary:** for metal, wood & plastic
- 2- **Rotary with percussion** for construction materials
- 3- **CHISELLER** for construction materials
- 4- **Vario - lock** to adjust the chisel position

- Electronic speed regulator
- VAT: vibration absorbing system



- Included:**
- Auxiliary lateral handle
 - Depth regulator
 - HD-PE Carry Case





ROTARY HAMMER SDS-PLUS

HD 5 CK

Cod. 1.1562

Power	1500	W
No load speed	0 - 850	rpm
Impacts	0 - 4300	ipm
Impact energy	5	J
Insertion	SDS-PLUS	
Max. wood drilling	ø40	mm
Max. steel drilling	ø13	mm
Max. masonry drilling	ø30	mm
Max. core drilling	ø70	mm
Weight	5	kg

- Hammer with 4 Functions

- 1- **Rotary**: for metal, wood & plastic
- 2- **Rotary with percussion** for construction materials
- 3- **CHISELLER** for construction materials
- 4- **Vario - lock** to adjust the chisel position

- Electronic speed regulator
- **VAT**: vibration absorbing system

- Motor with safety clutch
- For concrete and masonry anchoring ø8-30 mm (optimal ø10-20 mm.)

Included:

- Auxiliary lateral handle
- Depth regulator
- HD-PE Carry Case



ROTARY HAMMER SDS-PLUS

HD XT 6JK

Cod. 1.3088

Power	1500	W
No load speed	260 - 1050	rpm
Impacts	1380 - 5570	ipm
Impact energy	6	J
Insertion	SDS-PLUS	
Max. wood drilling	ø 40	mm
Max. steel drilling	ø 13	mm
Max. masonry drilling	ø 32	mm
Max. core drilling	ø 75	mm
Weight	5	kg

- Martillo con 3 funciones

- 1- **Rotary with percussion** for construction materials
- 2- **CHISELLER** for construction materials
- 3- **Vario - lock** to adjust the chisel position

- Electronic speed regulator
- **VAT**: vibration absorbing system

INCLUDED:



NEW
Check availability



ROTARY HAMMER SDS-PLUS

HD 6 DK

Cod. 1.2312

Power	1500	W
No load speed	0 - 850	rpm
Impacts	0 - 4300	ipm
Impact energy	7	J
Insertion	SDS-PLUS	
Max. wood drilling	ø40	mm
Max. steel drilling	ø13	mm
Max. masonry drilling	ø32	mm
Max. core drilling	ø80	mm
Weight	5	kg

- Hammer with 4 Functions

- 1- **Rotary**: for metal, wood & plastic
- 2- **Rotary with percussion** for construction materials
- 3- **CHISELLER** for construction materials
- 4- **Vario - lock** to adjust the chisel position

- Electronic speed regulator
- **VAT**: vibration absorbing system

Included:

- Auxiliary lateral handle
- Depth regulator
- HD-PE Carry Case



ROTARY HAMMER SDS-MAX

HD 40 BK

Cod. 1.2037

Power	1100	W
No load speed	235 - 480	rpm
Impacts	1350 - 2750	ipm
Impact energy	10	J
Insertion	SDS-MAX	
Max. drill capacity	ø40	mm
Max. core drilling	ø80	mm
Weight	6.5	kg

- Hammer with 3 Functions

- 1- **Rotary with percussion** for construction materials
- 2- **CHISELLER** for construction materials
- 3- **Vario - lock** to adjust the chisel position

- Constant speed by tacometer
- Electronic speed regulator
- Motor with mechanic safety clutch
- Soft Start
- **VAT:** vibration absorbing system

Included:

- Auxiliary lateral handle
- HD-PE Carry Case



ROTARY HAMMER SDS-MAX

HD 45 BK

Cod. 1.3332

Power	1600	W
No load speed	0 - 560	rpm
Impacts	3800	ipm
Impact energy	10	J
Insertion	SDS-MAX	
Max. drill capacity	ø45	mm
Max. core drilling	ø100	mm
Weight	7	kg

Hammer with 3 Functions

- 1- **Rotary with percussion** for construction materials
- 2- **CHISELLER** for construction materials
- 3- **Vario - lock** to adjust the chisel position

- **12 funciones** de colocación del cincel en el portaherramientas.
- Constant speed by tacometer
- Electronic speed regulator
- Motor with mechanic safety clutch
- Soft Start
- **VAT:** vibration absorbing system



VARIO-LOCK

NEW
Check availability

- **VAT:** vibration absorbing system

- Included:**
- Auxiliary lateral handle
 - HD-PE Carry Case

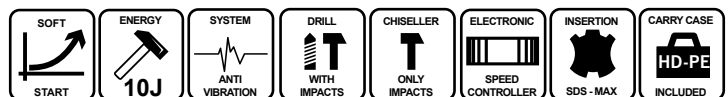

ROTARY HAMMER SDS-MAX

HD 50 BK

Cod. 1.1741

Power	1200	W
No load speed	280 - 550	rpm
Impacts	2900	ipm
Impact energy	20	J
Insertion	SDS-MAX	
Max. drill capacity	ø45	mm
Max. core drilling	ø120	mm
Weight	8.5	kg

- Hammer with 3 Functions

- 1- **Rotary with percussion** for construction materials
- 2- **CHISELLER** for construction materials
- 3- **Vario - lock** to adjust the chisel position

- Constant speed by tacometer
- Electronic speed regulator
- Motor with mechanic safety clutch
- Soft Start
- **VAT:** vibration absorbing system



Included:

- Auxiliary lateral handle
- HD-PE Carry Case





DEMOLITION HAMMER SDS-PLUS

MD 4 BK

Cod. 1.2921

Power	950	W
Impacts	4100	ipm
Impact energy	5	J
Insertion	SDS-PLUS	
Weight	3.5	kg

- Hammer with 2 Functions

- 1- **Chiseller** for construction materials
- 2- **Vario - lock** to adjust the chisel position
- Specialized mechanism with no rotation, only impacts
- **VAT:** sistema de reducción de vibraciones

Included:

- Auxiliary lateral handle
- x1 Pointer
- HD-PE Carry Case

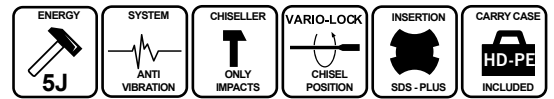

DEMOLITION HAMMER SDS-MAX

MD 6 CK

Cod. 1.1930

Power	1200	W
Impacts	2850	ipm
Impact energy	15	J
Insertion	SDS-MAX	
Weight	6.5	kg

- Hammer with 2 Functions

- 1- **Chiseller** for construction materials
- 2- **Vario - lock** to adjust the chisel position
- Specialized mechanism with no rotation, only impacts
- **VAT:** vibration absorbing system

Included:

- Auxiliary lateral handle
- x1 Pointer
- HD-PE Carry Case

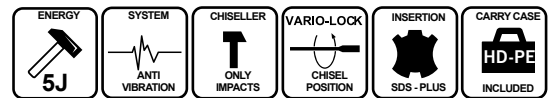

DEMOLITION HAMMER SDS-MAX

MD 10 K

Cod. 1.1364

Power	1500	W
Impacts	1000 - 1900	ipm
Impact energy	6 - 25	J
Insertion	SDS-MAX	
Weight	10	kg

- Hammer with 2 Functions

- 1- **Chiseller** for construction materials
- 2- **Vario - lock** to adjust the chisel position
- Specialized mechanism with no rotation, only impacts
- **VAT:** vibration absorbing system
- Electronic power and impacts regulator
- Soft Start
- Carbon brush wear out light level indicator

Included:

- Auxiliary lateral handle
- x1 Pointer
- HD-PE Carry Case

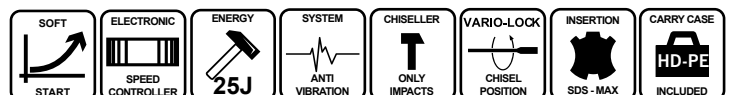

DEMOLITION HAMMER HEX 30

MD 15 BK

Cod. 1.2377

Power	1750	W
Impacts	1900	ipm
Impact energy	45	J
Insertion	HEX 30	
Weight	15	kg

- High performance electropneumatic system for demolition works.
- Compact and aerodynamic for an easy access to reduced spaces.
- **Double VAT:** vibration absorbing system.
- Additional vibration reducing system with springs located over the insertion to further reduce the user's exhaustion.

Included:

- Auxiliary lateral handle
- x1 Chisel
- x1 Pointer
- Trolley

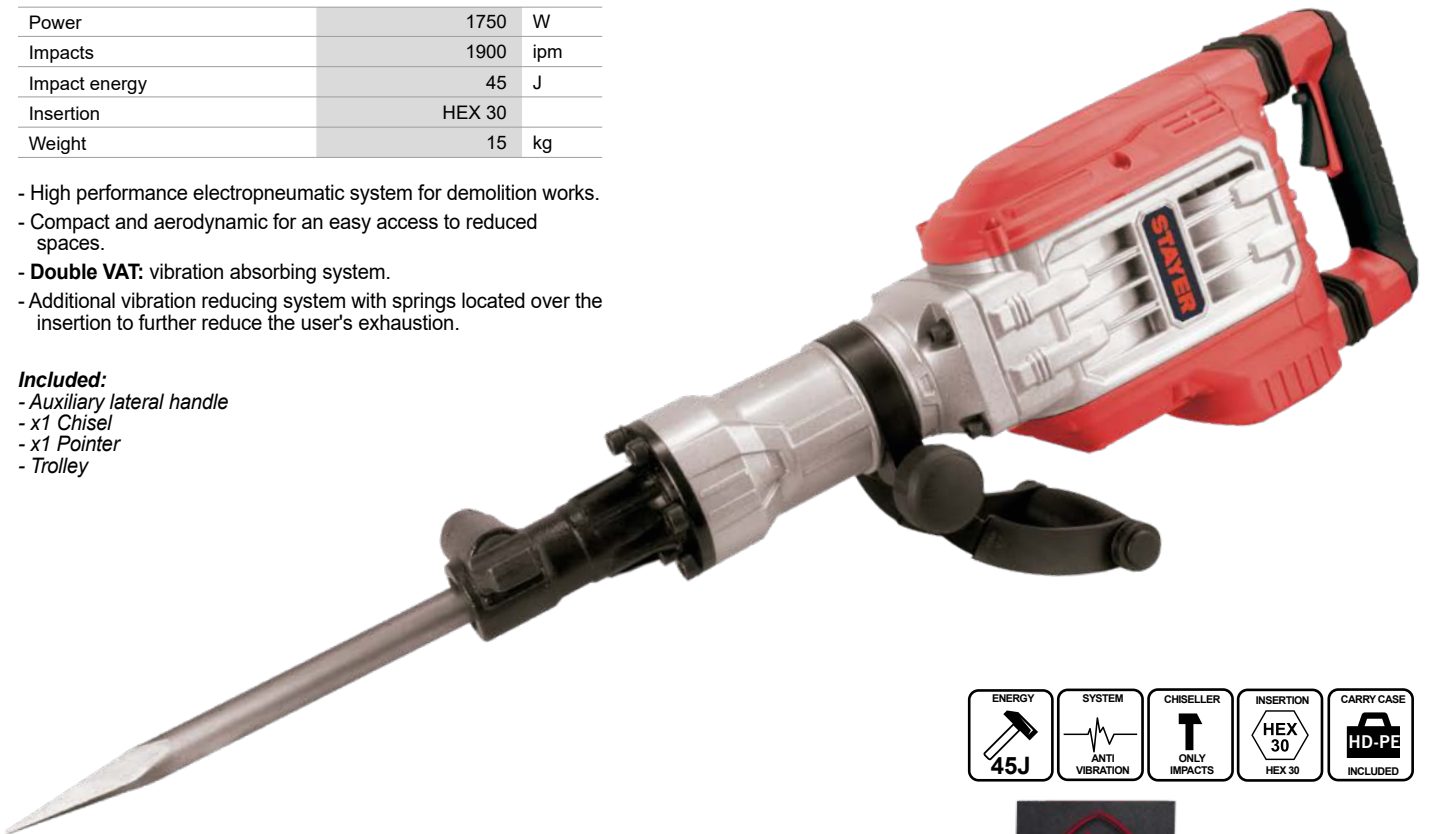

<p>ENERGY 45J</p>	<p>SYSTEM ANTI VIBRATION</p>	<p>CHISELLER ONLY IMPACTS</p>	<p>INSERTION HEX 30 HEX 30</p>	<p>CARRY CASE HD-PE INCLUDED</p>
------------------------------	----------------------------------	-----------------------------------	---	---

STANDS





WALL SANDER

HOT AIR GUNGS & MIXER

HOT AIR GUN

SU 650 EDK

Cod. 1.834

Power	2000	W
Airflow	250 - 500	l/min
Temperature	50 - 650	°C
Weight	0.9	kg

- Hot air gun with ceramic resistance
- Temperature & Airflow adjustable by microprocessor
- L.C.D screen with temperature control by 5 °C steps & airflow in 5 levels.
- Dries and peels varnish off. Folds plastic materials. Separates adhesive papers.

Included:

- Nozzle set
- HD -PE Carry Case

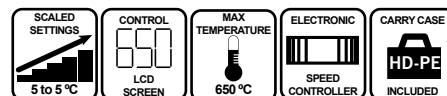

HOT AIR GUN

DX 1800 B

Cod. 1.2951

Power	1800	W
Airflow	300 - 500	l/min
Temperature	350 - 600	°C
Weight	0.9	kg

- Hot air gun with ceramic resistance
- 2 preset working modes airflow & Temperature:
 - 1- 350°C with 300 l/min
 - 2- 600°C with 500 l/min
- Dries and peels varnish off. Folds plastic materials. Separates adhesive papers.
- Reinforced head against high temperatures.

Included:

- x3 Nozzles
- x1 Scraper

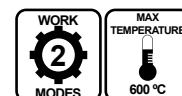

MIXER

M 1100 C

Cod. 1.2361

M 1100 CK

Cod. 1.2362

Power	1200	W
No load speed	180-430 / 300-680	rpm
Whisk diameter	ø120	mm
Insertion	M14	
Tightening Torque	14 - 30	Nm
Weight	4.8	kg

- Mixer with 2 Mechanical speeds
- Aluminum structure
- S1 constant service motor
- Suitable for paint and liquids as well as mortar and viscous materials
- 6 Levels electronic speed regulator.
- Ergonomic handles

Included:

- x1 whisk H2 - ø120 mm

M 1100 CK

Included:

- HD -PE Carry Case



MIXER

M 1200 C

Cod. 1.1474

M 1200 CK

Cod. 1.1475

Power	1200	W
No load speed	200-400 / 350-700	rpm
Whisk diameter	ø120	mm
Insertion	M14	
Tightening Torque	20.5	Nm
Weight	4.8	kg

- Mixer with 2 Mechanical speeds
- Aluminum structure
- S1 constant service motor
- Suitable for paints and liquids as well as mortar and viscous materials
- 6 Levels electronic speed regulator.
- Ergonomic handles
- Soft Start

Included:

- x1 whisk H2 - ø120 mm

M 1200 CK

Included:

- HD -PE Carry Case

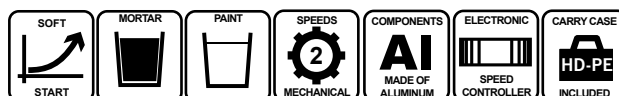

MIXER

M 1600

Cod. 1.1476

M 1600 K

Cod. 1.1477

Power	1600	W
No load speed	180-380 / 300-650	rpm
Whisk diameter	ø160	mm
Insertion	M14	
Tightening Torque	17 - 36	Nm
Weight	6	kg

- Mixer with 2 Mechanical speeds
- Aluminum structure
- S1 constant service motor
- Suitable for paint and liquids as well as mortar and viscous materials
- 6 Levels electronic speed regulator.
- Ergonomic handles
- Soft Start

Included:

- x1 whisk H2 - ø160 mm

M 1600 K

Included:

- x1 whisk H3 - 140 mm.
- HD-PE Carry Case

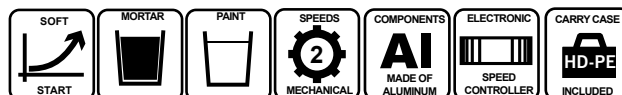

DUAL MIXER

DM 1600

Cod. 1.2649

Power	1600	W
No load speed (superior)	290-480	rpm
No load speed (inferior)	380-620	rpm
Capacity	90	L
Whisk diameter (superior)	ø140	mm
Whisk diameter (inferior)	ø112	mm
Insertion	M18	
Whisk length	600	mm
Weight	5	kg

- Aluminum structure
- S1 constant service motor
- Suitable for paint and liquids as well as mortar and viscous materials
- 6 Levels electronic speed regulator.
- Ergonomic handles
- Soft Start

Included:

- x1 whisk WK3 / M18 - 600 mm
- Upper whisk ø120 mm
- Lower whisk ø120 mm
- Carry bag

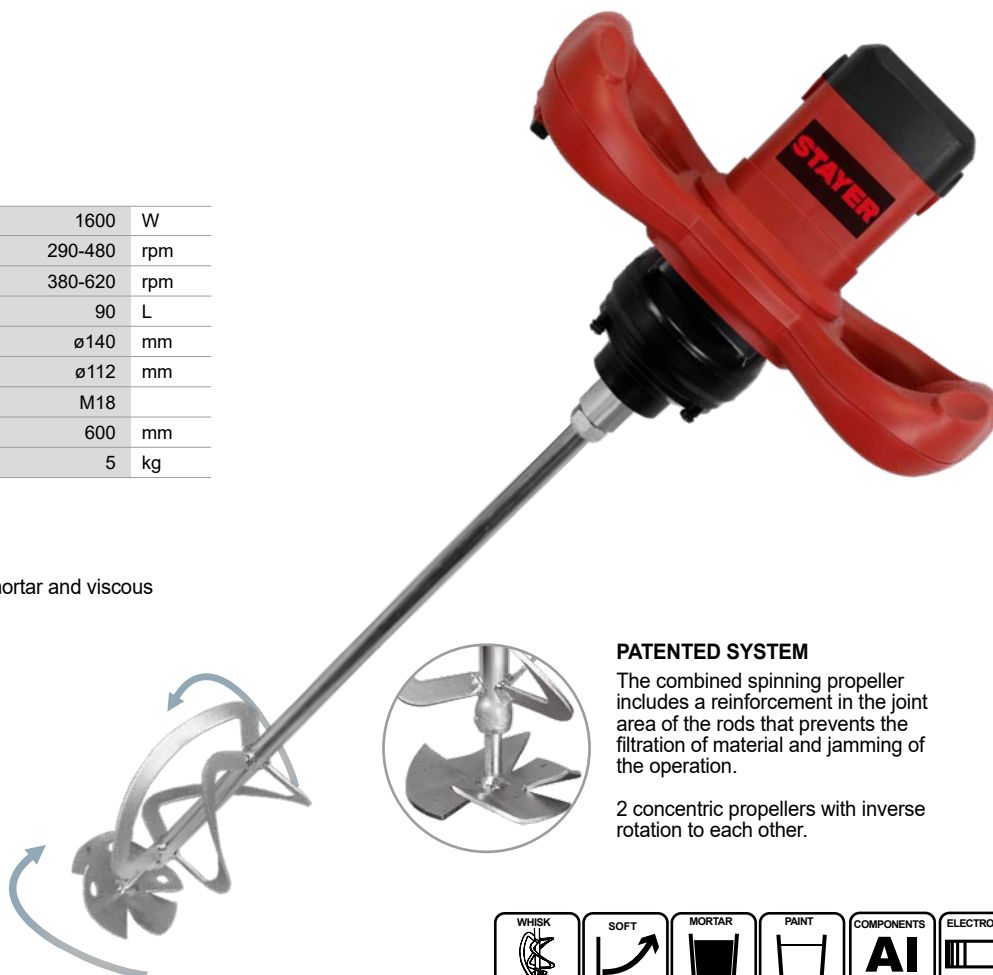

PATENTED SYSTEM

The combined spinning propeller includes a reinforcement in the joint area of the rods that prevents the filtration of material and jamming of the operation.

2 concentric propellers with inverse rotation to each other.

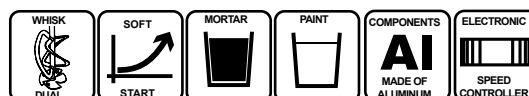



TELESCOPIC WALL SANDER

LP 700 E

Cod. 1.1450

Power	710	W
No load speed	800 - 1700	rpm
Work height	1600	mm
Plate size	ø225	mm
Vacuum coupling	ø45	mm
Head tiling	90	°
Weight	4.3	kg
Hose	3.5	m

- Built-in vacuuming system.
- Ready for coupling with an external vacuum cleaner.
- 2 Presets: Ceiling & Wall.
- Detachable carter for edges and corners sanding.
- 6 levels electronic speed regulator

Included:

- 5 Sanding sheets ø225 mm (P60, P80, P100, P180, P240)
- Hose 4m
- Vacuum coupling



**2 PRESETS
CEILING / WALL**

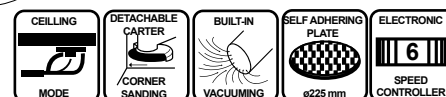

TELESCOPIC WALL SANDER

LP 710 E

Cod. 1.2140

Power	710	W
No load speed	1000 - 2100	rpm
Work height	1100- 1800	mm
Plate size	ø225	mm
Vacuum coupling	ø37,5	mm
Head tilting	90	°
Weight	4.4	kg
Hose	3.5	m

- Enhanced transmission wall sander
- Tilttable head to avoid wall scratching
- Coupling for an external vacuum cleaner.
- Detachable carter for edges and corners sanding.
- 6 levels electronic speed regulator

Included:

- 6 Sanding sheets ø225 mm (P80, P100, P120, P150, P180, P240)
- Hose 3.5 m
- Vacuum coupling



**OPTIMIZED TRANSMISSION
WITH SHORT**

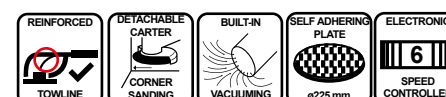

TELESCOPIC WALL SANDER

LP 710 DT

Cod. 1.2420

Power	710	W
No load speed	1000 - 2100	rpm
Work height	1100 - 1700	mm
Plate size	ø225	mm
Vacuum coupling	ø37.5	mm
Head tilting	90	°
Weight	4.4	kg
Hose	3.5	m

- Wall sander with anti dust sealed motor.
- Direct transmission
- Tilttable head to avoid wall scratching
- Built-in vacuuming system.
- Coupling for an external vacuum cleaner.
- 6 levels electronic speed regulator

**DIRECT TRANSMISSION
WITHOUT SHAFT**



Included:

- 6 Sanding sheets ø225 mm (P80, P100, P120, P150, P180, P240)
- Hose 3.5 m
- Vacuum coupling



TELESCOPIC WALL SANDER

LP 700 BRUSHLESS

Cod. 1.2912

Power	500	W
No load speed	1000 - 2100	rpm
Work height	ø225	mm
Plate size	ø38 - 47	mm
Head tilting	90	°
Weight	3.5	kg
Hose	4	m

- Wall sander with brushless motor located on the plate to avoid breakdowns and with a lighter weight.
- Powerful brushless motor for increased efficiency, significantly reducing heat build-up and considerably increasing motor life and battery life.
- Foldable for an easy transport and storage.
- Direct transmission
- Tiltable head to avoid wall scratching
- Lightweight 3.5 kg
- Reinforced aluminum structure
- Coupling for an external vacuum cleaner.
- Detachable carter for edges and corners sanding.
- 6 levels electronic speed regulator

MOTOR BRUSHLESS



Included:
- Hose 3.5 m
- Vacuum coupling

COMPONENTS AI MADE OF ALUMINUM	LIGHTWEIGHT	DETACHABLE CARTER CORNER SANDING	BUILT-IN VACUUMING	SELF ADHERING PLATE ø225 mm	ELECTRONIC SPEED CONTROLLER 7
---	-------------	-------------------------------------	-----------------------	--------------------------------	---

HAND WALL SANDER

HP 750 BE

Cod. 1.2239

Power	750	W
No load speed	1200 - 2200	rpm
Plate size	ø180	mm
Weight	2.4	kg

- Vertical motor wall sander.
- Built-in vacuuming system.
- Removes plastic paint, gotele & flattens drywall.
- Coupling for an external vacuum cleaner.
- Specially designed to completely sand walls, reaching corners and hard to reach areas.
- Detachable carter for edges and corners
- Levels electronic speed regulator



DETACHABLE CARTER CORNER SANDING	BUILT-IN VACUUMING	SELF ADHERING PLATE ø180 mm	ELECTRONIC SPEED CONTROLLER 6
-------------------------------------	-----------------------	--------------------------------	---

HAND WALL SANDER

HP 1010

Cod. 1.2129

Power	1010	W
No load speed	1000 - 1950	rpm
Plate size	ø225	mm
Weight	2.8	kg

- Wall sander with horizontal motor.
- Built-in vacuuming system.
- Adjustable disc height
- Removes plastic paint, gotele & flattens drywall.
- An external vacuum cleaner.
- Designed for both walls and ceiling sanding.
- Detachable carter for edges and corners sanding.
- 6 levels electronic speed regulator

Included:

- 6 Sanding sheets ø225 mm (P80, P100, P120, P150, P180, P240)
- Hose
- Vacuum coupling



DETACHABLE CARTER CORNER SANDING	BUILT-IN VACUUMING	SELF ADHERING PLATE ø180 mm	ELECTRONIC SPEED CONTROLLER 6
-------------------------------------	-----------------------	--------------------------------	---



TELESCOPIC WALL SANDER

LP 1050 AVS BRUSHLESS

Cod. 1.3315

Power	1050	W
No load speed	1500 - 2100	rpm
Work height	120-205	mm
Plate size	ø225	mm
Head tilt angle	90	°
Weight	3.2	kg

- Wall sander with brushless motor located on the plate to avoid breakdowns.
- Direct transmission
- Easy to work on the ceiling.
- Integrated suction system.
- Powerful brushless motor that allows to increase the efficiency, reducing the heating and increasing considerably the life of the motor and the battery life.
- Tilting head to avoid marks on the walls
- Removable carter for edges and corners sanding.
- Lightweight 3.2 kg.
- Reinforced aluminum structure.
- Speed regulator.

LED LIGHT
360°

ASPIRATION FAN

BRUSHLESS ENGINE LIGHTER

HANGING DUST BAG

TELESCOPIC

NEW
Check availability

AVS
AUTOMATIC VACUUM SYSTEM

INTEGRATED SUCTION
NO NEED FOR ADDITIONAL VACUUM CLEANER



TELESCOPIC WALL SANDER

LP 750 AVS

Cod. 1.3314

Power	750	W
No load speed	1000 - 1850	rpm
Work height	135-180	cm
Plate size	ø225	mm
Plate	8	agujeros
Head tilt angle	120	°
Weight	3.5	kg

- Wall sander
- Direct transmission
- Integrated suction system, which allows a vacuum on the walls, gripping and facilitating the movement of the plate.
- Tilting head to avoid marks on the walls
- Plegable para un fácil transporte y almacenaje.
- Removable carter for edges and corners sanding.
- LED light 360°.
- Lightweight 3.5 kg.
- Reinforced aluminum structure.

LED LIGHT
360°



ASPIRATION FAN

TELESCOPIC FOLDABLE

NEW
Check availability

AVS
AUTOMATIC VACUUM SYSTEM

INTEGRATED SUCTION
NO NEED FOR ADDITIONAL VACUUM CLEANER



HAND WALL SANDER

HP 1200
Cod. 1.3316

Power	1200	W
No load speed	2600	rpm
Plate size	ø225	mm
Weight	2.5	kg

- With led light for better visibility in the working area.
- Variable speed control 6 positions.
- Separate dust absorption system, which protects the motor from dust ingress.
- Removable carter for edges and corners sanding.
- Large handle.
- Dust bag with carrying belt.
- 360° LED light.

Included:

- Sanding sheets (gr 80/100/120/150/180 y 240 gr)
- 1 Adapter
- Dust bag



NEW
Check availability



WALL AND FLOOR TROWEL

CWS 410
Cod. 1.3145

Power	750	W
No load speed	100	rpm
Plate size	ø375	mm
Smoothed size	ø410	mm
Weight	3.5	kg

- The electroportable trowel is ideal for troweling, sanding, scraping, cleaning and roughing of walls and ceilings of mortars, plasters, thermal insulation panels...
- 750W polishing / sanding / smoothing machine with self-adhesive plate for smoothing, polishing and finishing of cement works.
- Balanced handles for easy sliding on the surface plastic plate for rough smoothing, sponge pad for finishing smoothing 375 mm sanding plate for covering large surfaces.
- Thermal smoothing wall grinding.
- Speed regulator to adapt the tool to the work to be done.
- Auxiliary upper handle for stable and homogeneous polishing.
- Spindle lock button for maximum safety against accidental start-up.
- Extension accessory (separate).

Included:



Smoothed plate
Cod. 12.930

It is suitable for rough smoothing and compacting concrete and structuring plasters.



Sandpaper
Cod. 12.929

For sanding insulation boards, polystyrene boards, mineral insulation.
24" grit



Sponge
Cod. 12.928

For finishing smoothing and cleaning of wet cement.
410mm



NEW
Check availability





AMOLADORAS

MINI ANGLE GRINDER ø115 mm

SAB 720

Cod. 1.2750

SAB 721

Cod. 1.2982



Power	720	W
No load speed	11000	rpm
Disc size	ø115	mm
Spindle thread	M14	
Weight	1.6	kg

- Reduced and compact angle grinder
- Extremely versatile & lightweight.

Included:

- 2 positions auxiliary handle.

SAB 721

For disc ø125 mm

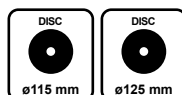

MINI ANGLE GRINDER

SAB 750 B

Cod. 1.3236

ERGONOMIC DESIGN

NEW
Check availability



Power	750	W
No load speed	13000	rpm
Disc size	ø115	mm
Spindle thread	M14	
Weight	1.45	kg

- Reduced and compact angle grinder
- Fully sealed switch.

- Extremely light and versatile

Included:

- 2 positions auxiliary handle.



MINI ANGLE GRINDER ø115 mm

SAB 800 CR

Cod. 1.1940

SAB 801 CR

Cod. 1.2009



Power	800	W
No load speed	11000	rpm
Disc size	ø115	mm
Spindle thread	M14	
Weight	1.7	kg

- Lightweight angle grinder with compact & balanced design.
- Powerful S1 constant service motor.
- Anti abrasion systems: double shielding, protection polymer, special cording & collector barrier.
- Assembled under pressure with 2 safety bolts
- Cooling systems: elongated rotor, cooling fan & 6 grids on the head.

Included:

- 2 positions auxiliary handle.

SAB 801 CR

For ø125 mm discs

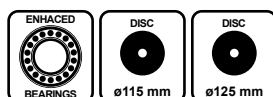

MINI ANGLE GRINDER ø115 mm

SAB 900 CR

Cod. 1.1719

SAB 901 CR

Cod. 1.1738



Power	900	W
No load speed	11000	rpm
Disc size	ø115	mm
Spindle thread	M14	
Weight	1.7	kg

- Lightweight angle grinder with compact & balanced design.

- Powerful S1 constant service motor 1.2 HP.
- Double shielded bearings
- Anti abrasion systems: double shielding, protection polymer, special cording & collector barrier.
- Assembled with 2 safety bolts
- Cooling systems: elongated rotor, cooling fan

Included:

- 3 Positions auxiliary handle

SAB 901 CR

For ø125 mm discs

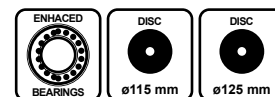



MINI ANGLE GRINDER ø125 mm

SAB 1011 B

Cod. 1.1640

SAB 1011 BE

Cod. 1.1687



SAB 1011 B SAB 1011 BE

Power	1000	1000	W
No load speed	10500	2800 - 11000	rpm
Disc size	ø125	ø125	mm
Spindle thread	M14	M14	
Weight	1.8	1.8	kg

- Angle grinder with compact & balanced design.
- Powerful S1 constant service motor.
- Double shielded bearings
- Anti abrasion systems: double shielding, protection polymer, special cording & collector barrier.
- Assembled with 2 safety bolts
- Cooling systems: elongated rotor, cooling fan & 6 grids on the head.

Included:

- 3 Positions auxiliary handle

SAB 1011 BE

6 Levels speed regulator

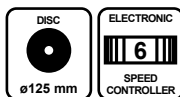

MINI ANGLE GRINDER ø125mm

SAB 1051 PS

Cod. 1.2506



Power	1050	W
No load speed	11000	rpm
Disc size	ø125	mm
Spindle thread	M14	
Weight	1.9	kg

- Lightweight angle grinder with compact & balanced design.
- Specially designed for industrial use.
- Safety paddle switch
- Powerful S1 constant service motor.
- Switch lock.
- Cooling systems: elongated rotor, cooling fan & 6 grids on the head.
- Anti sliding rubber coated body to reduce vibrations.

Included:

- 2 positions Auxiliary handle.

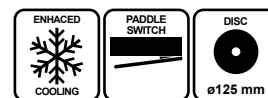

MINI ANGLE GRINDER ø125 mm

SAB 1351 CS

Cod. 1.1786



Power	1300	W
No load speed	2800 - 11000	rpm
Disc size	ø125	mm
Spindle thread	M14	
Weight	1.8	kg

- Maximum power 1300W
- Angle grinder with tacometer to keep constant power under load.
- 6 Levels electronic speed regulator
- Soft Start.
- External carbon brush replacement without tool disassembly.

Included:

- 3 Positions auxiliary handle

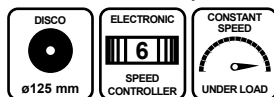

MINI AMOLADORA ANGULAR ø125 mm

SAB 1601 CS

Cod. 1.1970



Power	1600	W
No load speed	2800 - 11000	rpm
Disc size	ø125	mm
Spindle thread	M14	
Weight	1.8	kg

- Maximum power 1600W
- Angle grinder with tacometer to keep constant power under load.
- 6 Levels electronic speed regulator
- Soft Start.
- External carbon brush replacement without tool disassembly.

Included:

- 2 positions Auxiliary handle

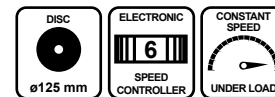

MINI ANGLE GRINDER ø125 mm

SAB 1201 IND

Cod. 1.2477



INDUSTRIAL USE

Power	1200	W
No load speed	11000	rpm
Disc size	ø125	mm
Spindle thread	M14	
Weight	1.8	kg

- Mini angle grinder for industrial use.
- Reinforced protections.
- No electronic plate for power surges.
- External carbon brush replacement without tool disassembly.
- Ready for industrial use under adverse conditions.

Included:

- 3 Positions auxiliary handle

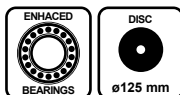

MINI ANGLE GRINDER Ø125 mm

SAB 1401 CE IND

Cod. 1.2793



INDUSTRIAL USE

Power	1400	W
No load speed	2800 - 10000	rpm
Disc size	ø125	mm
Spindle thread	M14	
Weight	2.2	kg

- Mini angle grinder for industrial use.
- Angle grinder with tacometer to keep constant power under load.
- External carbon brush replacement without tool disassembly.
- 6 levels electronic speed regulator.
- Ready for industrial use under adverse conditions.

Included:

- 3 Positions auxiliary handle

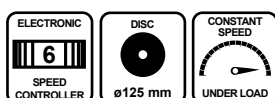

MINI ANGLE GRINDER ø125 mm

SAB 1101 CS

Cod. 1.2827



INDUSTRIAL USE

Power	1100	W
No load speed	2800 - 11000	rpm
Disc size	ø125	mm
Spindle thread	M14	
Weight	1.8	kg

- Specially designed to be used with 2 hands.
- Constant power under load.
- Anti sliding ergonomic rear handle.
- Flat head for narrow areas
- Long body, 28 cm without the head.
- 6 Levels electronic speed regulator.
- External carbon brush replacement without tool disassembly.
- Ready for industrial use under adverse conditions.

Included:

- Auxiliary handle with 2 positions

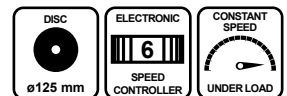

MINI ANGLE GRINDER ø125 mm

SAB 1701CS IND

Cod. 1.3138

NEW

MINI ANGLE GRINDER ø150 mm

SAB 1750CS IND

Cod. 1.3112



INDUSTRIAL USE

SAB 1701 CS IND SAB 1750 CS IND

Power	1700	1700	W
No load speed	2800-10000	2800-10000	rpm
Disc size	ø125	ø150	mm
Spindle thread	M14	M14	
Weight	3 kg	3	kg

- Mini angle grinder for industrial use.
- Angle grinder with tacometer to keep constant power under load.
- 6 levels electronic speed regulator.
- External carbon brush replacement without tool disassembly.
- Ready for industrial use under adverse conditions.

Included:

- 2 positions auxiliary handle

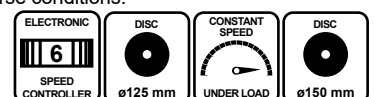



ANGLE GRINDER ø230 mm

AGR 2000

Cod. 1.2792

Power	2000	W
No load speed	6500	rpm
Disc size	ø230	mm
Spindle thread	M14	
Weight	4.2	kg

- Specially suited for workshops.
- External carbon brush replacement without tool disassembly.
- Soft Start
- Paddle switch with safety lock trigger



Included:
- 3 Positions auxiliary handle

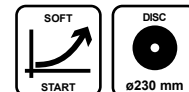

ANGLE GRINDER ø180 / ø230 mm

AGR 21-23 C

Cod. 1.2555

AGR 21-18 C

Cod. 1.2701

AGR 21-23 C AGR 21-18 C

Power	2100	2100	W
No load speed	6500	8000	rpm
Disc size	ø230	ø180	mm
Spindle thread	M14	M14	
Weight	4.2	4.2	kg

- **Powerful S1 constant service motor 2100W.**
- Reinforced transmission to reduce noises & improve the tool performance on long duration works
- Paddle switch with safety lock trigger
- Reinforced induction, quality gears & bearings.
- Specially suited for workshop and construction tasks.
- External carbon brush replacement without tool disassembly.



Included:
- 3 Positions auxiliary handle

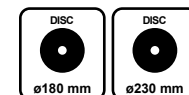

ANGLE GRINDER ø230 mm

AGR 22-23 C

Cod. 1.1909

Power	2200	W
No load speed	6500	rpm
Disc size	ø230	mm
Spindle thread	M14	
Weight	4.4	kg

- **Powerful S1 constant service motor 2200W.**
- **Rear rotary handle**
- Paddle switch with safety lock trigger
- Quality components: ball bearings & needles on every support. High performance sprocket & core.
- Specially suited for workshop and construction tasks.
- External carbon brush replacement without tool disassembly.



Included:
- 3 Positions auxiliary handle
- **OPTIONAL: HD-PE Carry Case**



ANGLE GRINDER \varnothing 180 / \varnothing 230 mm

AGR 24-23 CAL

Cod. 1.1816

AGR 24-18 CAL

Cod. 1.1895

	AGR 24-23 CAL	AGR 24-18 CAL	
Power	2400	2400	W
No load speed	6500	8000	rpm
Disc size	\varnothing 230	\varnothing 180	mm
Spindle thread	M14	M14	
Weight	4.4	4.4	kg



- Powerful S1 constant service motor 2400W.
- Rear rotary handle
- Paddle switch with safety lock trigger & NVR system
- Specially suited for workshop, quarry and construction tasks.
- External carbon brush replacement without tool disassembly.
- Soft Start

Included:
 - 3 Positions auxiliary handle
 - OPTIONAL: HD-PE Carry Case

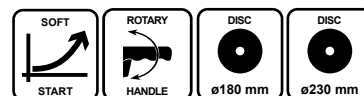

ANGLE GRINDER \varnothing 230 mm

SAB 26-23 AL

Cod. 1.1689

Power	2600	W
No load speed	6500	rpm
Disc size	\varnothing 230	mm
Spindle thread	M14	
Weight	4.4	kg



- Powerful S1 constant service motor 2600W.
- Quality components: ball bearings & needles on every support. High performance sprocket & core.
- Specially suited for workshop, quarry and construction tasks.
- External carbon brush replacement without tool disassembly.
- Soft Start
- Paddle switch with safety lock trigger

Included:
 - 3 Positions auxiliary handle

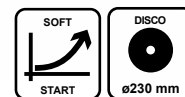

CONCRETE CUTTING MACHINE \varnothing 350 mm

CCM 350

Cod. 1.3352

Power	3200	W
Voltage	220/230	V
No load speed	2600	
Disc size	\varnothing 300-350	rpm
Max. cutting depth	300 (122) / 345 (147)	mm
Cutting width	25,4	mm
Weight	11	kg

NEW
 Check availability



- Particularly suitable for construction work that requires cutting of bulky or deep pieces.
- Powerful brushless motor for increased efficiency, significantly reducing heat build-up and considerably increasing motor life and battery life.
- Soft start
- Cooling.
- PRCD protection switch

Included:
 - Disc \varnothing 300mm





Angle grinder suction housing

Aspiration casing for cutting

Cod. 12.465

Aspiration casing for cutting in construction materials.
Grinder neck Ø 39 - 52mm, using washers.
-Fixing wrench with long nipples, for the disc fixing washer.
-Knob for suction housing.



Color	Size	Wall thickness
BLACK	51.5 x 45 mm	3 mm
BLACK	51.5 x 42 mm	4.5 mm (STAYER compatible)
BLACK	51.5 x 40 mm	5.5 mm
BLACK / RED	51.5 x 44 mm	3.45 mm
METAL	51.5 x 48 mm	1.5 mm (STAYER compatible)
BLACK / RED	51.5 x 43 mm	4 mm

6 WASHERS



MINI GRINDER CUTTING WITHOUT SUCTION HOUSING

Eje 14:
SAB801C, SAB901C, SAB1011B,
SAB1051PS, SAB1201IND,
SAB1351C, SAB1601.



MINI GRINDER CUTTING WITH SUCTION HOUSING



Aspiration casing for roughing

Cod. 12.459

Aspiration housing for roughing in construction materials.

Grinder neck Ø 39 - 52mm, using washers.

-Curved wrench, for the washer to fix the disc.



Color	Size	Wall thickness
NEGRO	51.5 x 45 mm	3 mm
NEGRO	51.5 x 42 mm	4.5 mm
NEGRO	51.5 x 40 mm	5.5 mm
NEGRO / ROJO	51.5 x 44 mm	3.45 mm
METÁLICO	51.5 x 48 mm	1.5 mm
NEGRO / ROJO	51.5 x 43 mm	4 mm

Quick tightening nut

Cod. 11.4624

Compatible with all M14 brands
One-click locking of M14 nuts.
Diameter Ø 50mm.



Grinder holder Ø115-125mm

Cod. 12.300

The grinder holder can fix the machine firmly to control the cutting, make the work easier and safer.



DIE GRINDER

SD 27 CE

Cod. 1.1705

- Die grinder with great power (**750W**) with **Speed regulator** for mounted points and burrs with $\varnothing 6 / \varnothing 6.3 / \varnothing 8$ mm shaft.
- **Soft Start**: the tool reaches its full power 2 seconds after being switched on.
- **Electronic speed regulator with 6 levels** ranging from 10.000 up to 30.000 rpm
- **Built-in tacometer** to keep constant power under load.
- Specially designed motor to withstand dust.
- Electronic system to limit the input current on the tool switch on, keeping the constant speed even at low rpm.
- Safety switch against unintentional activations.
- Specially designed to grind weld lines, polish & brighten all types of materials, from wood to paint or metal. Excelet performance removing metal barbs & sharpening.
- Specially suited for corundum mounted burrs, flap wheels, hard metal burrs & wire brushes

Power	750	W
No load speed	10000 - 30000	rpm
Collet	$\varnothing 6 / \varnothing 6.3 / \varnothing 8$	mm
Weight	1.7	kg

Included:
 - x3 collets
 $\varnothing 6$ mm
 $\varnothing 6.3$ mm
 $\varnothing 8$ mm

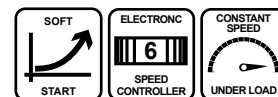

DIE GRINDER

SD 150 B

Cod. 1.2198



Power	1100	W
No load speed	6000	rpm
Collet	14	mm
Weight	4	kg

- Die grinder with powerful **S1** constant service motor.
- **Soft Start & Restart protection**
- Paddle switch with safety lock trigger
- Support for suspension belt.
- Specially meant for metal grinding and polishing.
- External carbon brush replacement without tool disassembly

Included:

- Grinding wheel $\varnothing 150 \times 20 \times 20$ mm



DUAL SAW FOR METAL CUTTING

DS 125

Cod. 1.1125



Power	950	W
No load speed	4200	rpm
Disc size	$\varnothing 125$	mm
Max. cutting depth	30	mm
Weight	3.2	kg

- Dual saw with **2** Widia discs $\varnothing 125$ mm.
- **Two opposed rotating discs** for a clean and quick cut without deformation.
- **Lubrication system with wax bars.**
- Rear rotary handle a $\pm 90^\circ$
- Safety paddle switch.
- Specially designed for metal cutting without sparks.

Included:

- Auxiliary handle
- x2 Widia discs $\varnothing 125$ mm Z32 (Cod. 1.1132)
- Wax bars (Cod. 11.5846)





POWER TOOLS

FOR WOOD, METAL & CONSTRUCTION

DIAMOND DISC WALL CHASER ϕ 125 mm

CD 125

Cod. 1.1254

Power	1500	W
No load speed	8500	rpm
Disc size	ϕ 125	mm
Cutting width	7 - 30	mm
Max. cutting depth	3 - 29	mm
Weight	5	kg

- Wall chaser with 2 diamond discs ϕ 125 mm.
- Adjustable cutting width with 2 diamond discs & 6 washers 4.5 mm included
- Overload control system. During a power surge, the machine switches off instantly until the safe situation returns, after 1 sec. it turns on again itself.
- Ready for coupling with an external vacuum cleaner.
- Cutting depth regulator.
- Paddle switch.
- External carbon brush replacement without tool disassembly.
- Soft Start



Included:

- Auxiliary handle
- Support roll
- x2 diamond discs ϕ 125 mm.
- x6 Washers 4.5 mm

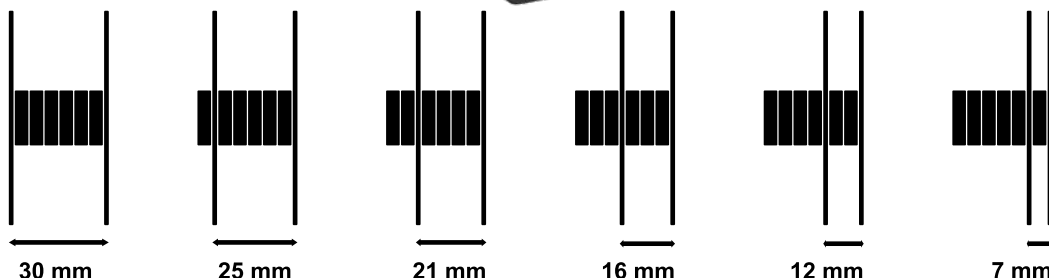

6 Different cutting widths



DIAMOND DISC WALL CHASER ϕ 150 mm

CD 150 B2 K (2 Diamond discs)

Cod. 1.2798

CD 150 B4 K (4 Diamond discs)

Cod. 1.2796

Power	2400	W
No load speed	8000	rpm
Disc size	ϕ 150	mm
Cutting width	7 - 35	mm
Max. cutting depth	8 - 43	mm
Weight	6	kg

- Wall chaser with 2 diamond discs ϕ 150 mm. (Optional 4)
- Adjustable cutting width with 2 diamond discs & washers included.
- Able to use up to 4 diamond discs. 25 mm slashes with 4 discs do not require chisel, 35 mm drastically reduce the need of chisel depending on the material cut.
- Ready for coupling with an external vacuum cleaner.
- Cutting depth regulator.
- Paddle switch.
- External carbon brush replacement.
- Soft Start

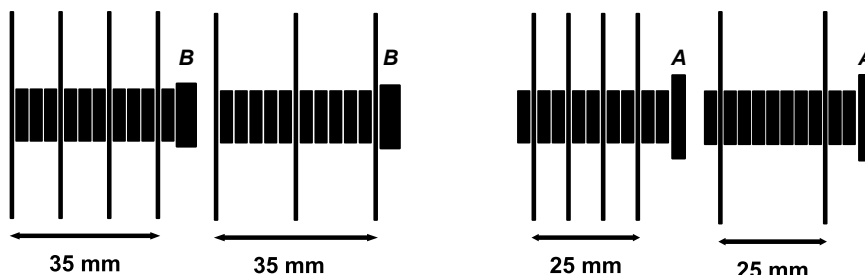

Included:

- Auxiliary handle
- Support rolls
- x2 diamond discs ϕ 150mm.
- x10 Washers 3 mm
- x1 Closing washer 20 mm
- x1 Closing washer 25 mm
- HD-PE Carry Case



DIAMOND DISC WALL CHASER \varnothing 180 mm

CD 180 K

Cod. 1.6007

Power	1800	W
No load speed	4100	rpm
Disc size	\varnothing 180	mm
Cutting width	9 - 51	mm
Max. cutting depth	15 - 54	mm
Weight	7.7	kg

- Wall chaser with 2 diamond discs \varnothing 180 mm.
- Adjustable cutting width with 2 diamond discs & washers included.
- 15 possible cutting configurations .
- Overload control system. During a power surge, the machine switches off instantly until the safe situation returns, after 1 sec. it turns on again itself.
- Ready for coupling with an external vacuum cleaner.
- Cutting depth regulator.
- Paddle switch.
- External carbon brush replacement without tool disassembly.
- Soft Start
- Wheels on the base for better slashing.

Included:

- Auxiliary handle
- x4 wheels
- x2 diamond discs \varnothing 180 mm.
- Washers:
 - x2 Washers 5mm
 - x1 Washer 10mm
 - x1 Washer 12mm
 - x1 Washer 15mm
- HD-PE Carry Case



MILLING CUTTER WALL CHASER

RF 1100 K

Cod. 1.1654

Power	1100	W
No load speed	1600	rpm
Milling cutter diameter	\varnothing 78	mm
Cutting width	25	mm
Max. cutting depth	11 - 30	mm
Weight	6.5	kg

- Wall chaser with \varnothing 78 mm milling cutter & Cutting width 25 mm.
- Specially meant for bricks, cell concrete, soft materials & rendered concrete.
- Ready for coupling with an external vacuum cleaner.
- Cutting depth regulator.
- Paddle switch.
- Clean slashes with a single pass.

Included:

- Vacuum coupling
- Milling cutter \varnothing 78 mm
- HD-PE Carry Case



CIRCULAR SAW Ø125 mm

CP 125

Cod. 1.1565

Power	1400	W
No load speed	12000	rpm
Disc size	ø125 x 22.2	mm
Max. cut at 45°	34	mm
Max. cut at 90°	40	mm
Weight	3.3	kg

- Mini circular saw with great power (1400W) Compact & balanced design.
- Anti dust protection system & quality bearings.
- Suitable for all kind of ø125 x 22.2 mm. discs. For all types of materials, from wood & laminated to porcelanic & marble.

CP 125 + Multimaterial disc (Cod. 1.2397)

- Included:
- Lateral guide
 - x1 multimaterial disc



OPTIONAL CP 125 + Diamond disc (Cod. 1.1565)

- Included:
- Lateral guide
 - x1 diamond disc

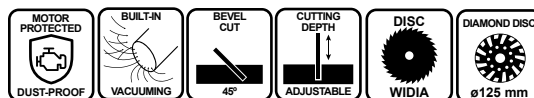

CIRCULAR SAW FOR METAL & SANDWICH PANELS ø230 mm

CM 230 K

Cod. 1.5977

Power	1700	W
No load speed	2600	rpm
Disc size	ø230 x 25.4	mm
Max. cut at 90°	84	mm
Max. cut at 45°	56	mm
Weight	7.1	kg

- Circular saw for widia discs of ø230 mm.
- Designed for dry cutting at low speeds without refrigeration needed.
- Specially designed for metal & sandwich panels cutting
- Oversized base for precision cuts.
- Cutting depth regulator.
- Bevel cuts 45°.

- Included:**
- Cutting guide
 - Widia disc ø230 x 25.4 mm





CIRCULAR SAW WITH GUIDE ø125 mm

SCP 125 DIAMANT

Cod. 1.2829

Power	1400	W
No load speed	13800	rpm
Disc size	ø125 x 22.2	mm
Max. cut at 45°	22	mm
Max. cut at 90°	39	mm
Guide (x3 segments)	1500 x 183 x 9.5	mm
Weight	2.5-	kg

- Circular saw for ceramic materials, porcelanic, natural & artificial stone.
- Aluminum cutting guide 1.5 meters (x3 segments 50 cm).
- Water cooling system. The tool includes a faucet coupling and a hose with flow regulator.
- Power cable with normative safety switch to work with water.
- The tool includes 2 suction cups & 2 clamps to secure the material to be cut, for maximum precision
- Cutting depth regulator.
- Bevel cuts 45°.
- Anti sliding ergonomic handle

Included:

- 1.5 m. Cutting guide with 3 segments of 50 cm
- STAYER Turbo Extrafino Profesional H10 disc ø125 mm.
- Hose with flow regulator & faucet coupling
- x2 Suction cups for the guide
- x2 Clamps for the guide
- Carry bag



X2 SUCTION CUPS FOR CUTTING GUIDE



X2 CLAMPS FOR CUTTING GUIDE

PRCD SAFETY SWITCH



WATER COOLING HOSE

GUIA DE CORTE:
0.5 metros Cod. 12.888
1 Metro Cod. 12.894



WATER COOLING HOSE



Included DIAMOND DISC TURBO EXTRAFINO PROFESIONAL H10 Ø125 MM

CIRCULAR SAW WITH GUIDE ø185 mm

CPT 3000 E

Cod. 1.1726

Power	1400	W
No load speed	2000 - 5000	rpm
Disc size	ø185 x 30	mm
Max. cut at 90°	67	mm
Max. cut at 45°	47	mm
Max. cut at 90° with guide	62	mm
Max. cut at 45° with guide	44	mm
Weight	4	kg

- Circular saw for widia discs of ø185 mm.
- Aluminum cutting guide 3 meters (3 segments of 1 meter).
- Electronic speed regulator
- Electronic system to keep constant speed under load.
- Specially suited for aluminum, wood & laminated floor.
- Ready for coupling with an external vacuum cleaner.
- Cutting depth regulator.
- Bevel cuts 45°.
- Ergonomic handles

Included:

- 3m. guide made of 3 segments 1m
- Widia disc ø185 x 30 mm

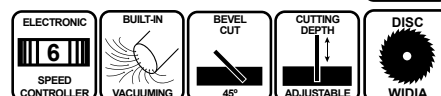

CIRCULAR SAW \varnothing 190 mm

CP 190 D

Cod. 1.2662

Power	1600	W
No load speed	5500	rpm
Disc size	\varnothing 190 x 30	mm
Max. cut at 90°	66	mm
Max. cut at 45°	44	mm
Weight	4	kg

- Circular saw for widia discs of \varnothing 190 mm.
- Specially suited for wood & laminated floors
- Ready for coupling with an external vacuum cleaner.
- Cutting depth regulator.
- Bevel cuts 45°.
- Ergonomic handles

Include:

- Cutting guide
- Widia disc \varnothing 190 x 30 mm

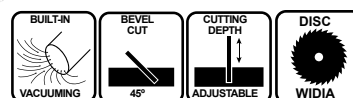

CIRCULAR SAW \varnothing 235 mm

CP 236

Cod. 1.5916

Power	2000	W
No load speed	4500	rpm
Disc size	\varnothing 235 x 30	mm
Max. cut at 90°	85	mm
Max. cut at 45°	58	mm
Weight	7.2	kg

- Circular saw for widia discs of \varnothing 235 mm.
- Aluminum cast base with 29 cm scale.
- Specially suited for wood & laminated floors
- Ready for coupling with an external vacuum cleaner.
- Cutting depth regulator.
- Bevel cuts 45°.

Included:

- Cutting guide
- Widia disc \varnothing 235 x 30 mm

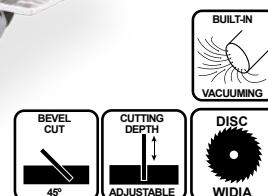

PROFESSIONAL QUALITY

SPEED & PRECISION

> CP 190D

STAYER



CIRCULAR SAW \varnothing 190 mm

CP 190 G

Cod. 1.3318

Power	1600	W
No load speed	5500	rpm
Disc size	\varnothing 190 x 30	mm
Max. cut at 90°	66	mm
Max. cut at 45°	45	mm
Weight	5	kg

- Circular saw for widia discs of \varnothing 190 mm.
- Specially suited for wood & laminated floors
- Ready for coupling with an external vacuum cleaner.
- Cutting depth regulator.
- Bevel cuts 45°.
- Ergonomic handles

Include:

- Cutting guide
- Widia disc \varnothing 190 x 30 mm



OPTIONAL

Cutting guide 1meter

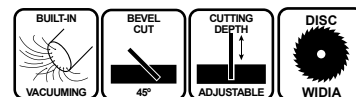

CIRCULAR SAW \varnothing 235 mm

CP 236 G

Cod. 1.3319

Power	2000	W
No load speed	4500	rpm
Disc size	\varnothing 235 x 30	mm
Max. cut at 90°	85	mm
Max. cut at 45°	60	mm
Weight	8.8	kg



OPTIONAL

Cutting guide 1meter

COMPATIBLE GUIDES

Cod. 12.917

CP 190 G // CP236G



JIG SAW

JS 80 B PE

Cod. 1.3186

Power	650	W
No load speed	500 - 3000	rpm
Max. cut wood	80	mm
Max. cut steel	8	mm
Max. cut Aluminum	22	mm
Weight	2.1	kg
Bevel cut	0-15-30-45	

- Quick blade change. T Insertion
- Pendular cutting. 3 Positions
- Prepared for bevel cuts from 0 to 45°.
- 6 levels electronic speed regulator
- Ready for coupling with an external vacuum cleaner

Includes:

- Laser cutting guide
- x1 Wood saw
- x1 Metal saw
- Lateral guide



NEW
Check availability

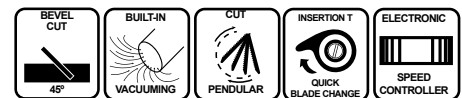

JIG SAW

S 90 PE

Cod. 1.1457

Power	800	W
No load speed	0 - 3000	rpm
Max. cut wood	100	mm
Max. cut steel	10	mm
Max. cut plastic	100	mm
Bevel cut	0 - 15 - 30 - 45	°
Weight	2.3	kg

- Quick blade change. T Insertion
- Pendular cutting. 3 Positions
- 6 levels electronic speed regulator
- Ready for coupling with an external vacuum cleaner
- Laser cutting guide

Included:

- Lateral guide

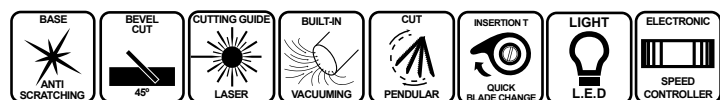

JIG SAW

S 110 PE

Cod. 1.5936

Power	780	W
No load speed	0 - 3000	rpm
Max. cut wood	110	mm
Max. cut steel	8	mm
Max. cut plastic	100	mm
Bevel cut	0 - 15 - 30 - 45	°
Weight	2.9	kg

- Quick blade change. T Insertion
- Aluminum cast head
- Pendular cutting. 3 Positions
- 6 levels electronic speed regulator
- Ready for coupling with an external vacuum cleaner
- Laser cutting guide

Included:

- Lateral guide
- x2 saw blades





RECIPROCATING SAW

SS 210 B

Cod. 1.2765

Power	1050	W
Saws per minute	0 - 2800	spm
Saw displacement	29	mm
Max. cut wood	210	mm
Max. cut steel	20	mm
Max. cut Aluminum	30	mm
Max. cut PVC/profiles	110	mm
Weight	3.4	kg



- Quick blade change. Universal insertion
- Rotary handle
- Electronic speed regulator.
- Rubber coated housing
- Adjustable depth regulator with no tools
- L.E.D worklight

Included:
- x1 Saw blade 150 mm.

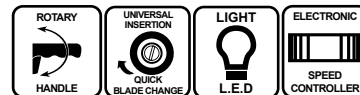

RECIPROCATING SAW

SS 280 P

Cod. 1.2001

Power	1200	W
Saws per minute	800 - 2800	spm
Saw displacement	28	mm
Max. cut wood	230	mm
Max. cut steel	25	mm
Max. cut aluminum	35	mm
Max. cut PVC/profiles	120	mm
Weight	3.7	kg



- Quick blade change. Universal insertion
- Pendular cutting. 4 Positions
- 6 levels electronic speed regulator
- Rubber coated housing
- Adjustable depth regulator with no tools
- L.E.D worklight

Included:
- x2 Saw blades

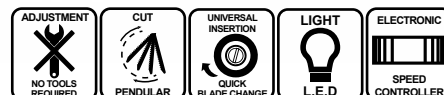

OSCILLATING MULTI TOOL

MULTI TOOL PRO 300 K

Cod. 1.1567

Power	300	W
No load speed	15000 - 23000	rpm
Orbit	3.2	mm
Weight	1.5	kg



- Oscillating multi tool with quick accessory replacement.
- Flat open insertion with great compatibility.
- Electronic speed regulator
- Built-in vacuuming. Ready for coupling with an external vacuum cleaner.
- Great versatility: cuts & sands all kind of materials from wood & metals to porcelanic. Also suitable for paint scraping & carpets.

Included:
- Hose
- Self adhering sanding sheets
- Self adhering delta plate
- Semicircular saw HCS
- Die saw HCS
- Scraper
- HD - PE Carry Case



POLISHER

LU 260 CE

Cod. 1.1931

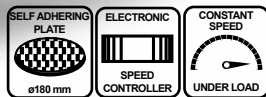

Power	1200	W
No load speed	600 - 3200	rpm
Plate size	ø180	mm
Spindle	M14	
Weight	3	kg

- Self adhering plate ø180 mm.
- Constant speed electronic system under load
- 6 levels electronic speed regulator
- Specially suited for metal sanding & polishing
- Adjustable auxiliary handle.
- Ergonomic rear handle
- External carbon brush replacement without tool disassembly.

Included:

- Self adhering plate
- Wool pad

POLISHER

PL 2500 E

Cod. 1.5678

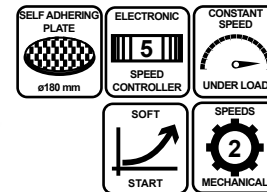

Power	800	W
No load speed	800 / 1200 - 4000	rpm
Plate size	ø170	mm
Spindle	M14	
Weight	2.3	kg

- Polisher with self adhering plate ø170 mm.
- Constant speed electronic system under load
- 5 levels electronic speed regulator
- 2 Mechanical speeds to adapt to all kind of jobs
- Vertical motor to reach narrow areas.
- Specially suited for metal sanding & polishing
- External carbon brush replacement without tool disassembly.
- Soft Start
- Plate lock against unintentional activations.

Included:

- Self adhering plate
- Wool pad

DRUM SANDER

LS 1200 B

Cod. 1.2010

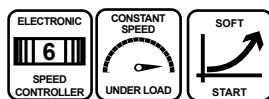

Power	1300	W
No load speed	900 - 3000	rpm
Max roll diameter	ø100 - 125	mm
Max roll width	100	mm
Spindle	M8	
Weight	4.6	kg

- Drum sander with S1 constant service motor for rolls ø100 - 125 mm
- Constant speed under load
- 6 levels electronic speed regulator.
- External carbon brush replacement without tool disassembly.
- Soft Start
- Spindle lock for easy roll replacement
- Specially suited for rust removal, sanding, polishing on metals as well as wood structuring.

Included:

- Auxiliary handle

DRUM SANDER

LSR 1200

Cod. 1.1804



Power	1300	W
No load speed	1000 - 3000	rpm
Max roll diameter	ø125	mm
Max roll width	100	mm
Spindle	M8	
Weight	4.1	kg

- Drum sander built with an angle grinde's body,
- S1 constant service motor for rolls ø125 mm
- Constant speed electronic system under load
- 6 levels electronic speed regulator.
- External carbon brush replacement without tool disassembly.
- Soft Start.
- Spindle lock for easy roll replacement.
- Carter with front roll to ease the work.
- Specially suited for rust removal, sanding, polishing on metals as well as wood structuring.

Included:

- Auxiliary handle

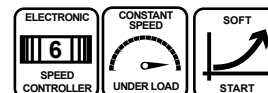



ROTORBITAL SANDER

RO 125

Cod. 1.2404

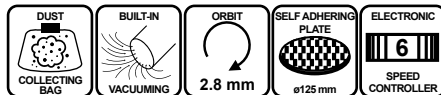

Power	300	W
No load speed	4000 - 12000	rpm
Plate size	ø125	mm
Orbit	2.8	mm
Weight	1.4	kg

- 6 levels electronic speed regulator
- Self adhering plate
- Low vibration

Included:

- Auxiliary lateral handle.
- Dust collecting bag.
- Sanding disc

ROTORBITAL SANDER

RO 752 EK

Cod. 1.1495



Power	750	W
No load speed	1600 - 5800	rpm
Plate size	ø150	mm
Orbit	5	mm
Vibrations per minute	3200 - 11600	mm
Forced rotation	180 - 700	mm
Weight	2.4	kg

3 Functions with adjustable orbit:

- 1- Eccentric movement at high RPM: for roughing down, heavy sanding & borders.
- 2- Eccentric movement at low RPM: for sanding and polishing.
- 3- Eccentric movement without forced rotation (Rotorbital) for fine sanding & moldings.

- Self adhering plate
- Built-in vacuuming
- Soft Start

Included:

- 3 Sanding sheets
- Wool pad.
- Foam plate
- HD-PE Carry Case
- Auxiliary handle.

ROTORBITAL SANDER

RO 150 E

Cod. 1.638



Power	450	W
No load speed	4000 - 13000	rpm
Plate size	ø150	mm
Orbit	2.5	mm
Weight	2.4	kg

- 5 levels electronic speed regulator
- Self adhering plate

Included:

- Auxiliary lateral handle.
- Dust collecting bag.
- Sanding disc

ROTORBITAL SANDER BRUSHLESS MOTOR

RO 2.5 BRUSHLESS

Cod. 1.2663

RO 5 BRUSHLESS

Cod. 1.2194



	RO 2.5 BRUSHLESS	5 BRUSHLESS	
Power	400	400	W
No load speed	4000 - 10000	4000 - 10000	rpm
Plate size	ø150	ø150	mm
Orbit	2.5	5	mm
Weight	1.28	1.28	kg

SPECIAL for BODYWORK **SPECIAL for WOOD**

- **Powerful motor brushless** with 400 W that increases the tool's lifespan while enhancing its power.
- Suitable for woodworking, bodywork, Corian counters.
- **Self adhering plate 150 mm with 15 holes** for an optimal vacuuming.
- **Paddle switch** with anti sliding handle.
- Symetric structure, allows to use the tool with both hands.
- **7 levels speed regulator** : 4000/ 5000/ 6000/ 7000/ 8000/ 9000 & 10.000 rpm.
- **Tacometer to keep the tool's power constant under heavy duty**

ORBITAL SANDER WITH 3 PLATES

LOM 130 3P

Cod. 1.2543

Power	190	W
No load speed	11000	rpm
Orbit	2	mm
Weight	1.3	kg

- Compact sander for **wood & drywall**.
- Designed to be used single-handedly.
- Suitable for damp sanding.
- Rubber coated head to reduce vibrations.
- Dust protection between the plate and the motor
- Double sanding sheet holding system: **Self adhering plate & clamps**
- Built-in vacuuming. Ready for coupling with an external vacuum cleaner.
- Unique model, **capable to double face sanding**.
- Specially designed for wood blinds sanding

Included:

- Dust collecting bag.
- Rectangular plate 85 x 135 mm.
- Double face plate 85 x 200 mm / 85 x 60 mm.
- Delta plate 89 x 225 mm.
- **x11 Rectangular sanding sheets** 85 x 135 mm.
x2 P40 / x3 P60 / x4 P80 / x2 P120
- **x11 Delta sanding sheets** 90 x 225 mm.
x2 P40 / x3 P60 / x4 P80 / x2 P120
- **x11 Double face Sanding sheets** 80 / 85 x 255 / 260 mm.
x2 P40 / x3 P60 / x4 P80 / x2 P120



Included X33 Sanding sheets

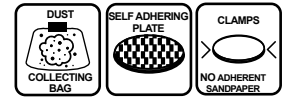

ORBITAL SANDERS

DELTA 150

Cod. 1.2374



- One-handed delta sander
- Anti vibration system.
- Built-in vacuuming
- Self adhering plate

Included:

- Dust collecting bag
- Split sanding delta sheets
x2 P60 / x2 P80 / x2 P120

Power	150	W
No load speed	14000	rpm
Plate size	150 x 150 x 100	mm
Weight	0.9	kg

LOM 180

Cod. 1.2553



- Aluminum base.
- Clamps for no adherent sandpapers
- Built-in vacuuming
- Self adhering plate
- Ergonomic design

Included:

- Dust collecting bag.
- x1 Sanding sheet.

Power	260	W
No load speed	12000	rpm
Plate size	90 x 185	mm
Orbit	2	mm
Weight	2.4	kg

LOM 230

Cod. 1.2135



- Powerful S1 constant service motor.
- Clamps for no adherent sandpapers
- Built-in vacuuming
- Self adhering plate
- Ergonomic design with reduced vibrations

Included:

- Dust collecting bag
- x2 Sanding sheets P80.

Power	400	W
No load speed	12000	rpm
Plate size	115 x 230	mm
Orbit	2	mm
Weight	2.9	kg

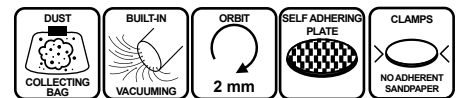
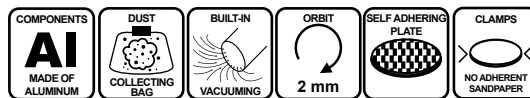
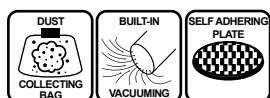



BELT SANDER

LEN 610

Cod. 1.5636



Power	1200	W
No load speed	500	rpm
Belt size	100 x 610	mm
Sanding surface	100 x 155	mm
Weight	2.3	kg

- **Belt sander with powerful belt transmission motor.**
- Powerful Built-in vacuuming system.
- Ready for coupling with an external vacuum cleaner.
- Aluminum structure.
- Double handles for safe sanding.
- Quick and easy sanding belt replacement.

Included:

- x1 Sanding sheet P80
- Vacuum coupling
- Dust collecting bag



PIPE SANDER

LT 1401 EK

Cod. 1.1368

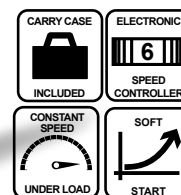

Power	1400	W
No load speed	750 - 3000	rpm
Belt speed	2.7 - 8.5	m/s
Belt size	40 x 760	mm
Weight	3.7	kg

- **Powerful sander with S1 constant service motor**
- **Constant speed electronic system under load**
- 6 levels electronic speed regulator
- Wide sanding arc 270°. For pipes up to \varnothing 180 mm.
- High stability pulleys with double bearings.
- Sanding belt quick replacement with no tools
- Adjustable belt tension
- Soft Start

Included:

- Auxiliary handle
- Aluminum carry case
- x9 Sanding belts 40 x 760 mm (x3 P60 / x3 P120 / x3 P240)



PLANER

P 910 B

Cod. 1.2754



Power	900	W
No load speed	16000	rpm
Routing depth	0 - 3	mm
Depth levels	14	
Planing width	82	mm
Weight	2.8	kg

- **Powerful cepillo with powerful belt transmission motor**
- **Depth regulator by milimeter quaters**
- Powerful Built-in vacuuming system.
- Ready for coupling with an external vacuum cleaner.
- Quick blade change

Included:

- Lateral guide
- Dust collecting bag
- Blade set

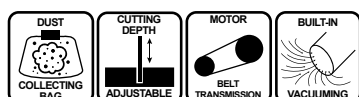

BISCUIT JOINER

BJ 120 B

Cod. 1.2691



Power	900	W
No load speed	11000	rpm
Max. routing	13 x 4	mm
Biscuits	0 - 10 - 20	n°
Milling cutter size	\varnothing 100 x 4 x 22	mm
Tilted cut	0 - 90°	mm
Max. work height	35	mm
Weight	3.2	kg

- **Biscuit joiner for wood panels.**
- **Specially designed for marquetry & cabinetry**
- Ready for n° 0, n° 10 & n°20 biscuits
- Routing 45° and up to 35 mm height

Included:

- Milling cutter
- Dust collecting bag

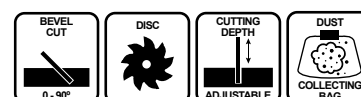

HINGE ROUTER

PRP 6

Cod. 1.2141

Power	480	W
No load speed	27000	rpm
Collet	ø6 - ø8	mm
Routing depth	0 - 30	mm
Weight	1.6	kg

- **Light router specially designed for hinge placing on wood profiles and doors .**

- Millimetric guide with depth regulator for maximum routing control.
- Ready for coupling with an external vacuum cleaner.
- Quick router bit replacement with no additional tools needed.



Included:

- x1 die router bit ø14 mm
- Vacuum coupling
- Lateral guide

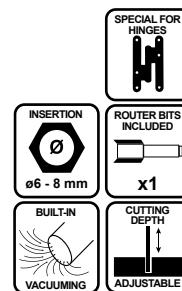

ROUTER

PR 6

Cod. 1.653

Power	550	W
No load speed	32000	rpm
Collet	ø6	mm
Routing depth	0 - 30	mm
Weight	1.8	kg

- **Lightweight router.**

- Millimetric guide with depth regulator for maximum routing control.
- Adjustable lateral guide.
- External carbon brush replacement without tool disassembly.

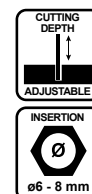

Included:

- Lateral guide
- Precision guide for curved routing

ROUTER

PR 10 EK

Cod. 1.1310

Power	1800	W
No load speed	8000 - 30000	rpm
Collet	ø6 / 6.3 / 8 / 12 / 12.7	mm
Routing depth	0 - 60	mm
Weight	4	kg

- **Double handle router for router bits from ø6 mm up to ø12.7 mm.**

- **6 levels electronic speed regulator**
- Millimetric guide with depth regulator for maximum routing control.
- Turret system for flattening irregular surfaces.
- Ready for template routing
- Ready for coupling with an external vacuum cleaner.

Included:

- x6 Router bits
- x6 Clamps ø6 / 6.3 / 8 / 12 / 12.7 mm.
- Lateral guide
- Template platform
- HD-PE Carry Case





BLOWER

SP 700

Cod. 1.2409

Power	480	W
No load speed	0 - 16000	rpm
Airflow	3	m ³
Weight	1.6	kg

- Lightweight blower for dust, leaves and workshop cleaning.
- Cable 2m.
- Flexible pipe.
- Ergonomic handle
- Trigger interlock for extender tasks.



SOLIDS & LIQUIDS VACUUM CLEANER / BLOWER

BVAC 2000

Cod. 1.2181

Power	1200	W
Socket power output	2000	W
Suction capacity	17	Kpa
Tank capacity	30	L
Hose size	ø38 x 1500	mm
Telescopic tube	40 - 80	cm
Cable	5	m
Weight	9.5	kg

- Solids & Liquids vacuum cleaner.
- HEPA Filter cleaning button blocking the nozzle.
- Output power socket to switch tools.
- Built-in blower.
- Tank level indicator.
- Built-in accessories housing.
- 4 Wheels to ease works on great surfaces.

Included:

- Flexible hose
- Vacuum coupling
- Telescopic tube
- 2 Positions brush
- Flat nozzle
- Round brush
- HEPA Filter

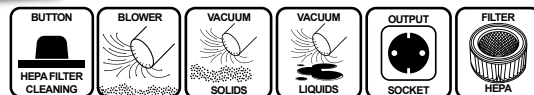
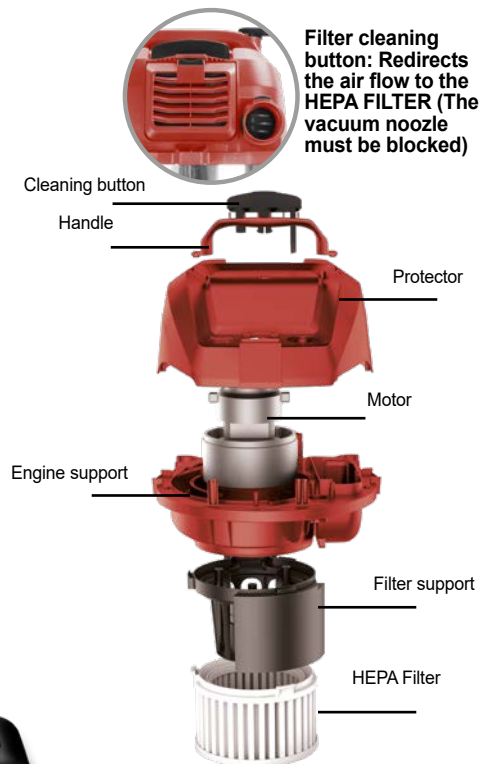

SOLIDS & LIQUIDS VACUUM CLEANER / BLOWER

BVAC 2200 E

Cod. 1.1898

Power	1600	W
Socket power output	2200	W
Suction capacity	18	Kpa
Tank capacity	30	L
Hose size	ø32 x 3000	mm
Telescopic tube	40 - 80	cm
Cable	4.5	m
Weight	6	kg

Included:

- Flexible hose
- Vacuum coupling 27 to 40 mm
- Telescopic tube
- Bristle brush (for carpets)
- Floor brush (for liquids).
- Flat nozzle
- Round brush
- HEPA Filter
- x2 washable dust bags

- Solids & Liquids vacuum cleaner with triple filter.
- HEPA Filter cleaning button blocking the nozzle.

- Output socket to connect a tool to the vacuum cleaner. Activating the connected tool activates the vacuum cleaner simultaneously. When the tool is stopped the vacuum keeps working for 8 seconds to completely remove dust.

- Built-in blower.
- Electronic power regulator.
- Quick and easy conversion, DRY to WET system (Change the filter for solids and install the sponge/filter for liquids).
- 4 Wheels to ease works on great surfaces.
- Class protection IPX4

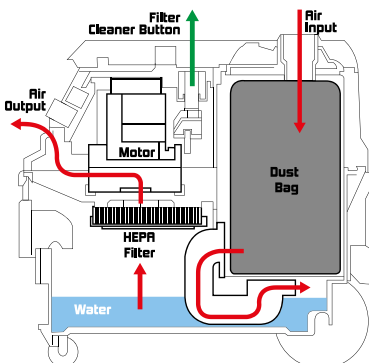

SOLIDS & LIQUIDS VACUUM CLEANER

VAC 2030

Cod. 1.1690

VAC 2050 C

Cod. 1.1198

VAC 2030 VAC 2050 C

Power	1200	1200	W
Socket power output	2000	2000	W
Suction capacity	17	17	Kpa
Tank capacity	30	50	L
Hose size	ø38 x 1500	ø38 x 1900	mm
Telescopic tube	40 - 80	40 - 80	cm
Cable	4.5	4.5	m
Weight	11	11	kg

- Solids & Liquids vacuum cleaner.
- VAC 2050 C Includes an HEPA Filter, Draining hose & greater tank capacity.
- Output socket to connect a tool to the vacuum cleaner. Activating the connected tool activates the vacuum cleaner simultaneously. When the tool is stopped the vacuum keeps working for 8 seconds to completely remove dust.
- Soft Start.
- 4 Wheels to ease works on great surfaces

Included:

- Flexible hose
- Vacuum coupling
- Telescopic tube
- 2 Positions brush
- Flat nozzle
- Round brush
- Dust bag

VAC 2030

Included:

- Washable filter bag
- Sponge filter

VAC 2050 C

Included:

- HEPA Filter
- Anti-static chain

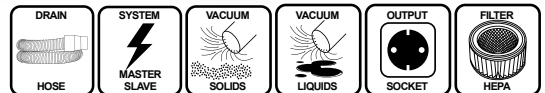

SOLIDS & LIQUIDS VACUUM CLEANER

BVAC 2400 DM

Cod. 1.2412

Power	1200 - 2400	W
Socket power output	2000	W
Suction capacity	23	Kpa
Tank capacity	60	L
Hose size	ø38 x 4000	mm
Cable	4.5	m
Weight	23	kg

**DOUBLE ENGINE
MAXIMUM POWER**

- Solids & Liquids vacuum cleaner with 2 independent motors of 1200W each one.
- HEPA Filter cleaning button blocking the nozzle.
- Output power socket to switch tools. The tool & the vacuum cleaner must be activated separately.
- Internal buoy to control the tank level.
- Draining hose built-in the tank.
- 4 Wheels to ease works on great surfaces.
- Class protection IPX4

Included:

- Flexible hose
- Vacuum coupling
- Metal 2 pieces tube
- Bristle brush (for carpets)
- Floor brush (for liquids).
- Flat nozzle
- Round brush
- HEPA Filter

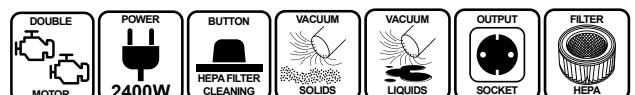



MITRE SAWS

BAND SAWS & CHOP SAWS

MITRE SAW ø210 mm

SC 210 CW

Cod. 1.2947

Power	1200	W
No load speed	4500	rpm
Disc size	ø210 x 30	mm
Weight	12	kg



Cutting capacity: Max. Length x Max. Height (LxH)

Straight 90°	Mitre 45/90°	Bevel 90/45°	Combined 45/45°	Upper Table
120 x 55mm	65 x 55 mm	120 x 35 mm	40 x 23 mm	0-33 mm

- Mitre saw with upper saw table for widia discs of ø210 mm.
- Single-phase motor 1200W.
- Aluminum tough design.
- Rotary table with angle presets at every 5°
- Scaled cutting guide

Included:

- Widia disc TCT ø210 x 30 mm
- Expandable cutting supports.
- Parallel upper guide.
- Disc protector.
- Vertical clamp
- Dust collecting bag

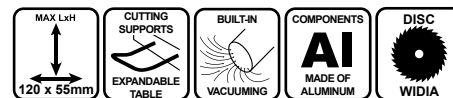

COMBINED MITRE SAW ø250 mm

SC 250 CW

Cod. 1.2943

Power	1800	W
No load speed	4800	rpm
Disc size	ø255 x 30	mm
Weight	16	kg



Cutting capacity: Width x Height (W x H)

Straight 90°	Mitre 45/90°	Bevel 90/45°	Compound 45/45°	Upper Table
150 x 70 mm	110 x 70 mm	150 x 40 mm	110 x 40 mm	0 - 38 mm

- Combined mitre saw with upper saw table for widia discs of ø210 mm.
- Single-phase motor 1800W.
- Aluminum design.
- Rotary table with angle presets at every 5°
- Scaled cutting guide

Included:

- Widia disc TCT ø250 x 30 mm
- Expandable cutting supports.
- Parallel upper guide.
- Disc protector.
- Vertical clamp
- Dust collecting bag

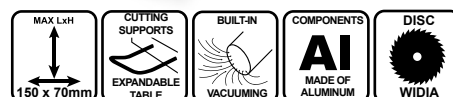



MITRE SAW $\varnothing 254$ mm

SC 250 W PRO

Cod. 1.1377

Power	1500	W
No load speed	3800	rpm
Disc size	$\varnothing 254 \times 30$	mm
Weight	14.5	kg

Cutting capacity: Max. Length x Max. Height (LxH)

Straight 90°	Mitre 45/90°	Bevel 90/45°	Combined 45/45°	Upper Table
155 x 70mm	105 x 70 mm	150 x 50 mm	55 x 50 mm	0-43 mm

- Mitre saw with upper saw table for widia discs of $\varnothing 254$ mm.
- Single-phase motor 1500W.
- Rotary table with angle presets at -45°, -22.5°, 0°, +22.5°, +45°

Included:

- Widia disc TCT $\varnothing 254 \times 30$ mm
- Length regulator.
- Parallel upper guide.
- Upper table goniometer.
- Disc protector
- Dust collecting bag

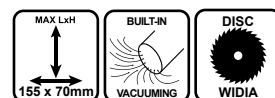

MITRE SAW $\varnothing 254$ mm

SC 265 W

Cod. 1.1105

Power	1500	W
No load speed	3800	rpm
Disc size	$\varnothing 254 \times 30$	mm
Weight	15.5	kg

Cutting capacity: Max. Length x Max. Height (LxH)

Straight 90°	Mitre 45/90°	Bevel 90/45°	Combined 45/45°	Upper Table
155 x 70mm	105 x 70 mm	150 x 20 mm	55 x 50 mm	0-43 mm

- Mitre saw with upper saw table for widia discs of $\varnothing 254$ mm.
- Aluminum cast table
- Single-phase motor 1500W.
- Base & upper table made of aluminum.
- Rotary table with angle presets at -45°, -22.5°, 0°, +22.5°, +45°

Included:

- Widia disc TCT $\varnothing 254 \times 30$ mm
- Length regulator.
- Parallel upper guide.
- Upper table goniometer.
- Disc protector
- Dust collecting bag

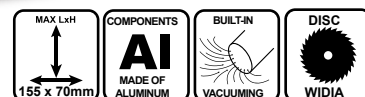





MITRE SAW ø254 mm

SC 2600 W

Cod. 1.1760

Power	1900	W
No load speed	2900	rpm
Disc size	ø254 x 30	mm
Weight	16.5	kg

Cutting capacity: Max. Length x Max. Height (LxH)

Straight 90°  135 x 55mm	Mitre 45/90°  90 x 55 mm	Bevel 90/45°  125 x 45 mm	Combined 45/45°  65 x 45 mm	Upper Table  0-45 mm
---	---	--	--	---

- Mitre saw with upper saw table for widia discs of ø254 mm.
- Cast luminium tough design with 3.2 mm. thickness
- Reinforced snode built in a single piece not attached to the base.
- Rotary table with angle presets at every 5°
- Adjustable upper table height.

Included:

- Widia disc TCT ø254 x 30 mm
- Expandable cutting supports.
- Parallel upper guide.
- Disc protector.
- Vertical clamp
- Dust collecting bag



MAX LxH 135 x 55mm	CUTTING SUPPORTS EXPANDABLE TABLE	BUILT-IN VACUUMING	COMPONENTS MADE OF ALUMINUM AI	DISC WIDIA
-----------------------	--------------------------------------	-----------------------	---	---------------





MITRE SAW ø254 mm

SC 251 NW

Cod. 1.2579

Power	1800	W
No load speed	5000	rpm
Disc size	ø254 x 30	mm
Weight	16.5	kg

Cutting capacity: Max. Length x Max. Height (LxH)

Straight 90°  127 x 75mm	Mitre 45/90°  90 x 75 mm	Bevel 90/45°  127 x 50 mm	Combined 45/45°  85 x 50 mm	Upper Table  52 mm
---	---	--	--	---

- Mitre saw with upper saw table for widia discs of ø254 mm.
- Max cutting capacity thank to the motor position.
- Single-phase motor 1800W.
- Cast aluminum tough design.
- Rotary table with angle presets at every 5°
- Scaled cutting guide

Included:

- Widia disc TCT ø254 x 30 mm
- Expandable cutting supports.
- Parallel upper guide.
- Disc protector.
- Vertical clamp
- Dust collecting bag



MAX LxH 127 x 75mm	CUTTING SUPPORTS EXPANDABLE TABLE	BUILT-IN VACUUMING	COMPONENTS MADE OF ALUMINUM AI	DISC WIDIA
-----------------------	--------------------------------------	-----------------------	---	---------------



NEW

MITRE SAW ø305 mm

SC 305 CW

Cod. 1.2944

Power	1800	W
No load speed	4800	rpm
Disc size	ø315 x 30	mm
Weight	29	kg

Cutting capacity: Max. Length x Max. Height (LxH)

Straight 90°	Mitre 45/90°	Bevel 90/45°	Combined 45/45°	Upper Table
170 x 100mm	118 x 100 mm	170 x 67 mm	118 x 62 mm	0 - 50 mm

- Mitre saw with upper saw table for widia discs of ø305 mm.
- Max. cutting precision.
- Belt transmission on both models.
- Reduced noise.
- Aluminum base & upper table.
- Great size table 476 x 326 mm.
- Rotary table with angle presets at every 5°
- Adjustable upper table height.

Included:

- Widia disc TCT ø315 x 30 mm
- Length regulator.
- Parallel upper guide.
- Disc protector.
- Vertical clamp
- Dust collecting bag



--	--	--	--	--

MITRE SAW ø305 mm

SC 305 W

Cod. 1.2578

SC 305 IW (INDUCTION MOTOR)

Cod. 1.2192

Power	1600	W
No load speed	3000	rpm
Disc size	ø305 x 30	mm
Weight	26	kg

Cutting capacity: Max. Length x Max. Height (LxH)

Straight 90°	Mitre 45/90°	Bevel 90/45°	Combined 45/45°	Upper Table
170 x 90mm	110 x 90 mm	170 x 60 mm	55 x 70 mm	0-50 mm

- Mitre saw with upper saw table for widia discs of ø305 mm.
- Max. cutting precision.
- Belt transmission on both models.
- Reduced noise.
- Aluminum base & upper table.
- Great size table 476 x 326 mm.
- Rotary table with angle presets at every 5°
- Adjustable upper table height.

Included:

- Widia disc TCT ø305 x 30 mm
- Length regulator.
- Parallel upper guide.
- Disc protector.
- Vertical clamp
- Dust collecting bag



**Belt transmission
Silent motor**



--	--	--	--	--	--

MITRE SAW - BELT TRANSMISSION \varnothing 315 mm

SCC 315 W

Cod. 1.2111

Power	2000	W
No load speed	4000	rpm
Disc size	\varnothing 315 x 30	mm
Weight	22	kg



Cutting capacity: Max. Length x Max. Height (LxH)

Straight 90°	Mitre 45/90°	Bevel 90/45°	Combined 45/45°	Upper Table
165 x 100mm	115 x 100 mm	170 x 65 mm	62 x 62 mm	0-45 mm

- Mitre saw with upper saw table for widia discs of \varnothing 315 mm.
- Max. cutting height 110 mm.
- Powerful belt transmission motor 2000W.
- Reduced noise.
- Aluminum base & upper table.
- Rotary table with angle presets at -45, -30°, -15°, -7.5°, 0°, +15°, +30°, +45°, +60°

Included:

- Widia disc TCT \varnothing 315 x 30 mm
- Expandable cutting supports.
- Parallel upper guide.
- Disc protector.
- Vertical clamp
- Dust collecting bag



**Belt transmission
Silent motor**

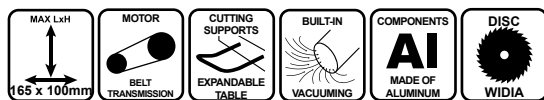

Mitre saw bench

T100C

Cod. 1.2889

Maximum load	150	Kg
Dimensions	19.85 x 6.40 x 9.35.	cm
Adjustable height	825-935	mm
Adjustable width	940-1985	mm
Maximum support surface	710 x 510	mm
Weight	9.8	Kg

High quality aluminum structure ideal for all project needs. Ergonomic lever quick clamps to fix the legs, work piece quick release mechanism.

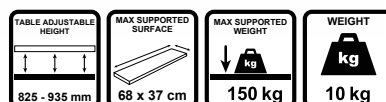

TELESCOPIC MITRE SAW $\varnothing 216$ mm

SCR 216 W

Cod. 1.2183

Power	1700	W
No load speed	4700	rpm
Disc size	$\varnothing 210 / 216 \times 30$	mm
Weight	12	kg

Cutting capacity: Max. Length x Max. Height (LxH)

Straight 90°	Mitre 45/90°	Bevel 90/45°	Combined 45/45°
340 x 65 mm	240 x 65 mm	340 x 40 mm	240 x 40 mm

- Telescopic mitre saw for widia discs of $\varnothing 216$ mm.
- Sliding head for great length cuts.
- Laser cutting guide
- Base made of aluminum.
- Rotary table with angle presets at $-45^\circ / -30^\circ / -22.5^\circ / -15^\circ / 0^\circ / +15^\circ / +22.5^\circ / +30^\circ / +45^\circ$

Included:

- Widia disc TCT $\varnothing 210 \times 30$ mm
- Expandable cutting supports.
- Vertical clamp
- Dust collecting bag

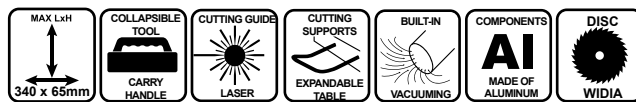

TELESCOPIC MITRE SAW $\varnothing 255$ mm

SCR 255 CW

Cod. 1.1676

Power	1800	W
No load speed	6000	rpm
Disc size	$\varnothing 255 \times 30$	mm
Weight	17.5	kg

Cutting capacity: Max. Length x Max. Height (LxH)

Straight 90°	Mitre 45/90°	Bevel 90/45°	Combined 45/45°
340 x 90 mm	240 x 90 mm	340 x 50 mm	240 x 45 mm

- Telescopic mitre saw for widia discs of $\varnothing 255$ mm.
- Sliding head for great length cuts.
- Belt transmission silent motor
- Laser cutting guide
- Base made of aluminum.
- Rotary table with angle presets at $-45^\circ / -30^\circ / -22.5^\circ / -15^\circ / 0^\circ / +15^\circ / +22.5^\circ / +30^\circ / +45^\circ$

Included:

- Widia disc TCT $\varnothing 255 \times 30$ mm
- Expandable cutting supports.
- Vertical clamp
- Dust collecting bag



**Belt transmission
Silent motor**

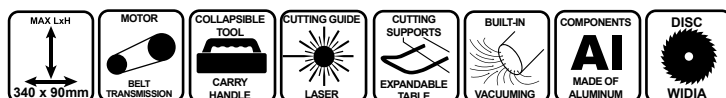

TELESCOPIC MITRE SAW \varnothing 315 mm

SCR 315 W

Cod. 1.1933

Power	1800	W
No load speed	3500	rpm
Disc size	\varnothing 315 x 30	mm
Weight	19	kg



**Belt transmission
Silent motor**

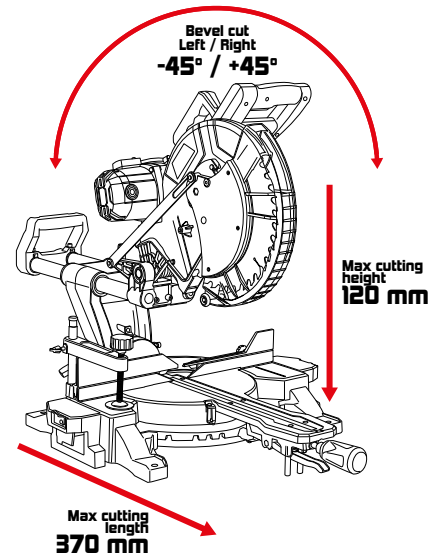

Cutting capacity: Max. Length x Max. Height (LxH)				
Straight 90°	Mitre 45/90°	Bevel 90/45°	Combined 45/45°	Combined Right.
370x105 mm	370x65 mm 370x35 mm	255x105 mm	255x65 mm	255x35 mm

- Telescopic mitre saw for widia discs of \varnothing 315 mm.
- Tilttable head rightwards and leftwards
- 120 mm max cutting height.
- Sliding head for great length cuts.
- Belt transmission silent motor
- Laser cutting guide
- Base made of aluminum.
- Scaled cutting guide for mayor exactitud
- Rotary table with angle presets at
-45° / -30° / -22.5° -15° / 0° / +15° / +22.5° / +30° / +45°

Included:

- Widia disc TCT \varnothing 315 x 30 mm
- Expandable cutting supports.
- Vertical clamp
- Dust collecting bag



 CUTTING SUPPORTS EXPANDABLE TABLE	 BUILT-IN VACUUMING	 COMPONENTS MADE OF ALUMINUM	 DISC WIDIA
 MAX LxH 370 x 120mm	 MOTOR BELT TRANSMISSION	 COLLAPSIBLE TOOL CARRY HANDLE	 CUTTING GUIDE LASER

ABRASIVE DISC CHOP SAW \varnothing 355 mm

TV 509 D

Cod. 1.1976

Power	2400	W
No load speed	4000	rpm
Disc size	\varnothing 355 x 25.4	mm
Weight	17	kg

Cutting capacity

Cuts at 90°	●	\varnothing 120	mm
(profile & solid)	■	115 x 115	mm
	└┘	120 x 120	mm
	▬	210 x 85	mm
Cuts at 45°	●	\varnothing 120	mm
(profile & solid)	■	100 x 100	mm
	└┘	100 x 100	mm
	▬	130 x 100	mm



- Metal chop saw with abrasive discs.
- Adjustable horizontal clamp -15° to +45° built-in.
- Single-phase motor
- Adjustable depth regulator
- Bevel cuts 0° a -45°
- Collapsible tool for transport & storage

Included:

- Iron cutting abrasive disc \varnothing 355 x 3.0 x 25.4 mm (Cod. 5.511)

 COLLAPSIBLE TOOL CARRY HANDLE	 BEVEL CUT 45°	 CUTTING DEPTH ADJUSTABLE	 DISC ABRASIVE
-----------------------------------	-------------------	------------------------------	-------------------



WIDIA DISC CHOP SAW \varnothing 185 mm

TD 185 (BRUSHLESS)

Cod. 1.3320

Power	1500	W
No load speed	1900 / 2300 / 2800	rpm
Disc size	\varnothing 185	mm
Weight	11	kg

Cutting capacity

Cuts at 90°		\varnothing 55	mm
(profile & solid)		45 x 45	mm
		35 x 85	mm
Cuts at 45°		\varnothing 45	mm
(profile & solid)		40 x 40	mm
		30 x 80	mm



Includes:
- Steel Disc 185 mm
Cod: 12.931



With the fastest cuts on the market



- **Brushless motor:** High torque and stable speed..
- **Powerful brushless motor** for increased efficiency, significantly reducing heat build-up and considerably increasing motor life and battery life.
- **Cutting-off machine** for fast and clean cutting of metals.
- **Hardened steel base.**
- **Soft start**
- **Constant speed.**
- **Aluminum cutting.**
- **Protection against disconnection (anti-rearming) and overload.**
- **Power on and overload indicator.**
- **3 speeds:**
 - 1900 rpm: Ferrous metals.
 - 2300 rpm: Non-ferrous metals
 - 2800 rpm: Stainless steel

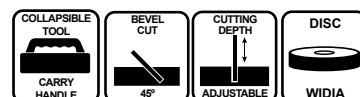

WIDIA DISC CHOP SAW \varnothing 355 mm

TD 355 B

Cod. 1.2507

Power	2200	W
No load speed	1500	rpm
Disc size	\varnothing 355 x 25.4	mm
Weight	22	kg

Cutting capacity

Cuts at 90°		\varnothing 130	mm
(profile & solid)		120 x 120	mm
		120 x 120	mm
		185 x 95	mm
Cuts at 45°		\varnothing 120	mm
(profile & solid)		90 x 90	mm
		90 x 90	mm
		105 x 90	mm



- **Metal chop saw with widia discs TCG.**
- **Adjustable horizontal clamp** -15° to +45° built-in.
- **Single-phase motor**
- **Iron cast base**
- **Adjustable depth regulator**
- **Bevel cuts 0° a -45°**
- **Collapsible tool** for transport & storage

Included:

- Widia disc TCG with sandwich teeth \varnothing 355 x 3 x 25.4 mm
10 times better performance over standard widia discs
(Cod. 12.660)

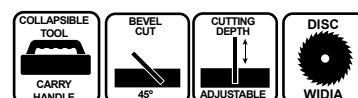

BAND SAW

SN 1435 B

Cod. 1.1460

Power	1/2	HP
No load speed	2000 - 4000	rpm
Blade size	1435 x 12.7 x 0.65	mm
Speed	38/80	m/min
Weight	21	kg

Cutting capacity

Cuts at 90° (profile & solid)	●	ø125	mm
	■	125 x 125	mm
	■	125 x 127	mm
Cuts at 45° (profile & solid)	●	ø80	mm
	■	80 x 80	mm
	■	80 x 100	mm
Cuts at 60° (profile & solid)	●	ø45	mm
	■	45 x 45	mm
	■	45 x 60	mm

- Powerful band saw.
- 2 Speed levels.
- Quick iron cast clamp 125 mm.
- Cast aluminum arc. Steel base.
- Length regulator.
- Bevel cuts 0° to 60°
- Adjustable blade tension.
- Collapsible tool for transport & storage.

Included:

- Bimetal saw blade



BAND SAW

SN 1735

Cod. 1.5882

Power	2000	W
Blade size	1735 x 13 x 0.65	mm
Speed	30 - 80	m/min
Weight	38	kg

Cutting capacity

Cuts at 90° (profile & solid)	●	ø155	mm
	■	155 x 155	mm
	■	165 x 150	mm
Cuts at 45° (profile & solid)	●	ø110	mm
	■	110 x 110	mm
	■	120 x 100	mm

- Band saw with powerful Single-phase motor.
- Quick clamp 165 mm.
- 2 Speed levels.
- Soft Start.
- Arc & base made of cast aluminum.
- Band tension wheel.

Included:

- Bimetal saw blade

OPTIONAL:

- Bench 57 x 46 x 80 cm
Weight 16 kg
Cod. 1.454

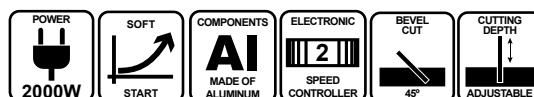

INDEX



Mitre Saws
96



Cordless Tools
97



Impact Drills
98



Rotary Hammers
99



Angle Grinders
100



Sanders
101



Saws & Planer
102

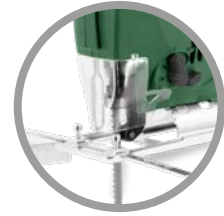

Jig Saws
103



Multi Tools
103



Bench Grinders
104



**Ash Cleaner &
Compressor**
105



Garden
106







STAYER



MITRE SAW SC 210 CW

Cod. 1.2945

Power	1200	W
No load speed	4500	rpm
Disc size	ø210 x 30	mm
Weight	12	kg

Cutting capacity: Width x Height (W x H)				
Straight 90°	Mitre 45/90°	Bevel 90/45°	Compound -45/45°	Upper Table
				
120 x 55mm	65 x 55 mm	120 x 35 mm	40 x 23 mm	0-33 mm

- Combined mitre saw with upper cutting table for ø210 mm widia discs.
- Single-phase 1200W motor.
- Robust aluminum design.
- Pre-adjusted rotary table for cuts at every 5°.
- Adjusted cutting guide

Included:



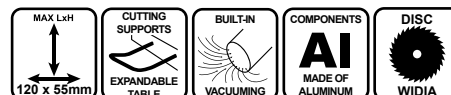

- TCT widia disc ø210 x 30 mm.
- Lower table extenders.
- Upper parallel guide.
- Lower disc cover.
- Vertical clamp
- Dust bag



MITRE SAW SC 250 W

Cod. 1.589

Power	1800	W
No load speed	4200	rpm
Disc size	ø250 x 30	mm
Weight	15.5	kg

Cutting capacity: Width x Height (W x H)				
Straight 90°	Mitre 45/90°	Bevel 90/45°	Compound -45/45°	Upper Table
				
130 x 80 mm	90 x 75 mm	130 x 52 mm	71 x 30 mm	0 - 40 mm

- Aluminum base and upper table.
- Vertical clamp
- Integrated suction.
- Automatic locking of the rotary table for cutting at 22.5°-45°-90°.
- Widia TCT Z40 disc.
- Lateral support for easy cutting of long pieces.
- 1 scalimeter to measure the cutting length.
- Sliding support to facilitate cutting at 45° inclined.

Included:

- Widia TCT disc ø250 x 30 mm.
- Lower table extenders.
- Upper parallel guide.
- Lower disc cover.
- Vertical clamp
- Dust bag

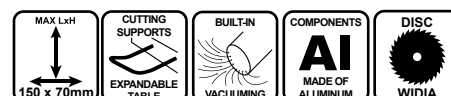



DRILL / SCREWDRIVER 12V

BHL 111 BK

Cod. 1.3063

Battery voltage - Lithium	12	V
Battery capacity	2.0	Ah
No load speed	0-350/0-1350	rpm
Chuck Capacity	ø1.5 - ø10	mm
Chuck insertion	3/8" x 24	UNF
Tightening Torque	32	Nm
Settings	16 + 2	
Max. wood drilling	ø20	mm
Max. masonry drilling	ø10	mm
Max. steel drilling	ø10	mm
Weight	0.9	kg



CHARGER & BATTERY

CHARGER 1.5 A

Cod. 12.900

BATTERY 1.5 Ah

Cod. 12.899

- 2 Functions: Screwdriver & Drill
- 2 Mechanical speeds for enhanced power & speed.
- Power controlled by trigger pressure.
- Reversible rotation.

Included:

- x1 Charger
- x2 Batteries 2.0Ah
- HD-PE Carry Case



DRILL / SCREWDRIVER / HAMMER DRILL 14.4V - 18V

Cod. 1.2914

BHL 114 CPK

Cod. 1.2012

BHL 118 BPK

Cod. 1.2988

BHL 118 CPK

NOVEDAD

Battery voltage - Lithium	14.4	18	18	V
Battery capacity	1.5	1.5	2	Ah
No load speed	0-400/0-1500	0-750/0-1500	0-750/0-1500	rpm
Impacts	0-6000 / 0-22000	0-6000 / 0-22000	0-6000 / 0-22000	
Chuck Capacity	ø0.8 - ø10	ø0.8 - ø10	ø0.8 - ø10	mm
Chuck insertion	3/8" x 24	3/8" x 24	3/8" x 24	UNF
Tightening Torque	25	32	32	Nm
Settings	17 + 1	17 + 1	17 + 1	
Max. wood drilling	ø30	ø32	ø32	mm
Max. masonry drilling	ø10	ø10	ø10	mm
Max. steel drilling	ø10	ø10	ø10	mm
Max. screws diameter	ø12	ø12	ø12	
Weight	1	1.5	1.5	kg

- 3 Functions: Drill, Screwdriver & Hammer drill
- Keyless Chuck with safety lock.
- Tightening torque with 17 + 1 settings.
- Belt clip: comfortable retaining clip to hang the tool on the belt between jobs.
- L.E.D. guide light at working area.

- 2 Mechanical speeds for a better tightening torque.
- Reversible and electronic with microprocessor.

Included:

- x1 Charger
- x2 Batteries 2.0Ah
- HD-PE Carry Case

BHL 114 CPK

CHARGER 1.5 A - 14.4V

Cod. 12.476

BATTERY 1.5 Ah - 14.4V

Cod. 12.478

BHL 118 BPK

CHARGER 2.0 A - 18V

Cod. 12.479

BATTERY 2.0 Ah - 18V

Cod. 12.477

BHL 118 CPK

CHARGER 2.0 A - 18V

Cod. 12.902

BATTERY 2.0 Ah - 18V

Cod. 12.901



HAMMER DRILL

TH 610

Cod. 1.1381

TH 610 A

Cod. 1.1382

Power	600	W
No load speed	0 - 3000	rpm
Impacts	0 - 41600	ipm
Chuck Capacity	ø2 - 13	mm
Insertion	1/2" x 20	UNF
Max. wood drilling	ø25	mm
Max. steel drilling	ø13	mm
Max. masonry drilling	ø13	mm
Weight	2	kg

TH 610

Included:

- Key chuck
- Auxiliary handle ajustable
- Depth regulator

TH 610 A

Included:

- Keyless chuck
- Auxiliary handle ajustable
- Depth regulator

- Drill with 2 functions: drill & impact drill
- Speed regulator located on the trigger
- Reversible by lever over the trigger



HAMMER DRILL

TH 710 BA

Cod. 1.2723

TH 710 BAK

Cod. 1.2690

Power	750	W
No load speed	0 - 3000	rpm
Impacts	0 - 48000	ipm
Chuck Capacity	ø2 - 13	mm
Insertion	1/2" x 20	UNF
Max. wood drilling	ø25	mm
Max. steel drilling	ø13	mm
Max. masonry drilling	ø13	mm
Weight	1.8	kg

TH 710 BA

Included:

- Auxiliary handle ajustable
- Depth regulator

TH 710 BAK

Included:

- Auxiliary handle ajustable
- Depth regulator
- HD-PE Carry Case

- Drill with 2 functions: drill & impact drill
- Keyless chuck
- Speed regulator located on the trigger
- Reversible with button located over the trigger.

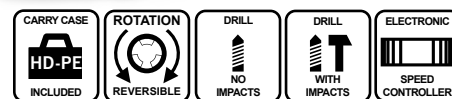

HAMMER DRILL

TH 1000 AK

Cod. 1.558

Power	1000	W
No load speed	0 - 3000	rpm
Impacts	0 - 44800	ipm
Chuck Capacity	ø2 - 13	mm
Insertion	1/2" x 20	UNF
Max. wood drilling	ø25	mm
Max. steel drilling	ø13	mm
Max. masonry drilling	ø13	mm
Weight	2.3	kg

- Drill with 2 functions: drill & impact drill
- Keyless chuck
- Speed regulator located on the trigger
- Reversible with button located over the trigger.

Included:

- Auxiliary handle ajustable
- Depth regulator
- HD-PE Carry Case





ROTARY HAMMER SDS-PLUS

MH 26 K

Cod. 1.1805

Power	800	W
No load speed	0 - 1300	rpm
Impacts	0 - 5500	ipm
Impact energy	2.8	J
Insertion	SDS-PLUS	
Max. wood drilling	ø30	mm
Max. steel drilling	ø13	mm
Max. masonry drilling	ø26	mm
Max. core drilling	ø68	mm
Weight	2.8	kg

- Hammer with 4 Functions

- 1- **Rotary**: for metal, wood & plastic
 - 2- **Rotary with percussion** for construction materials
 - 3- **CHISELLER** for construction materials
 - 4- **Vario - lock** to adjust the chisel position
- Electronic speed regulator
 - Safety clutch

Included:

- Auxiliary lateral handle
- Depth regulator
- HD-PE Carry Case

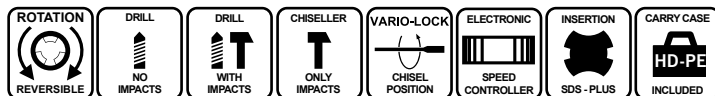

ROTARY HAMMER SDS-PLUS

MH 6 CK

Cod. 1.2313

Power	1700	W
No load speed	0 - 850	rpm
Impacts	4000	ipm
Impact energy	7	J
Insertion	SDS-PLUS	
Max. wood drilling	ø40	mm
Max. steel drilling	ø13	mm
Max. masonry drilling	ø26	mm
Max. core drilling	ø65	mm
Weight	5	kg

- Hammer with 4 Functions

- 1- **Rotary**: for metal, wood & plastic
 - 2- **Rotary with percussion** for construction materials
 - 3- **CHISELLER** for construction materials
 - 4- **Vario - lock** to adjust the chisel position
- VAT: vibration absorbing system
 - Safety clutch

Included:

- Auxiliary lateral handle
- Depth regulator
- HD-PE Carry Case



MINI ANGLE GRINDER \varnothing 115 mm

FH 700 C

Cod. 1.2730

Power	700	W
No load speed	11000	rpm
Disc size	\varnothing 115	mm
Spindle thread	M14	
Weight	1.6	kg

- Lightweight angle grinder with compact & balanced design.
- Powerful S1 constant service motor.
- Safety switch

Included:

- Auxiliary handle with 2 positions



MINI ANGLE GRINDER \varnothing 115 mm / \varnothing 125 mm

FH 900 G

Cod. 1.3020

FH 901 G

Cod. 1.2856

Power	900	W
No load speed	11000	rpm
Disc size	\varnothing 115	mm
Spindle thread	M14	
Weight	1.8	kg

- Lightweight angle grinder with compact & balanced design.
- Powerful S1 constant service motor.
- Safety switch

Included:

- Auxiliary handle with 2 positions

FH 901 F

For \varnothing 125 mm discs

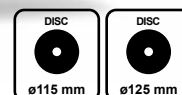

PROFESSIONAL QUALITY

LIGHT & COMPACT

> FH700C



GREEN LINE



DELTA SANDER

LD 141 B

Cod. 1.2781



Power	110	W
No load speed	12500	rpm
Plate size	140 x 140 x 80	mm
Weight	0.65	kg

- One-handed delta sander
- Anti vibration system.
- Built-in vacuuming
- Self adhering plate

Included:

- Vacuum coupling
- x1 Sanding sheet delta

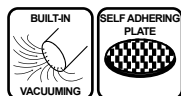

DELTA SANDER

LD 141 C

Cod. 1.3021



NEW
Check availability

Power	135	W
No load speed	14000	rpm
Plate size	140 x 140 x 80	mm
Weight	0.8	kg

- One-handed delta sander
- Anti vibration system.
- Built-in vacuuming
- Self adhering plate

Included:

- Vacuum coupling
- x1 Sanding sheet delta



ORBITAL SANDERS

LH 187 C

Cod. 1.1126



- Clamps for no adherent sandpapers
- Built-in vacuuming
- Self adhering plate

Included:

- Vacuum coupling.
- x2 Sanding sheets.

Power	150	W
No load speed	12000	rpm
Plate size	90 x 187	mm
Orbit	2	mm
Weight	1.2	kg

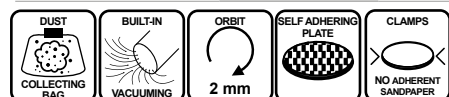

ROTORBITAL SANDER

LR 125 CE

Cod. 1.2190



- 6 levels electronic speed regulator
- Self adhering plate
- Low vibration

Included:

- Dust deposit.
- Sanding disc

Power	300	W
No load speed	12000	rpm
Plate size	ø125	mm
Orbit	2	mm
Weight	1.5	kg

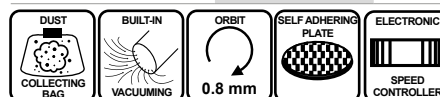

RECIPROCATING SAW

SSH 210

Cod. 1.2766



Power	900	W
Saws per minute	0 - 3000	spm
Saw displacement	22	mm
Max. cut wood	180	mm
Max. cut steel	10	mm
Max. cut aluminum	25	mm
Max. cut PVC/profiles	100	mm
Weight	3.2	kg

- Quick blade change. Universal insertion
- Rotary handle
- Electronic speed regulator.
- Rubber coated housing
- Adjustable depth regulator

Included:
- x1 Saw blade 150 mm.

NEW
Check availability

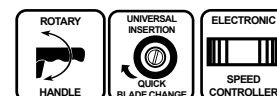

CIRCULAR SAW

CH 185 C

Cod. 1.1544

Power	1300	W
No load speed	4500	rpm
Size del disco	ø185 x 16	mm
Max. corte 90°	65	mm
Max. corte 45°	44	mm
Weight	4.8	kg

- Circular saw for widia discs of ø185 mm.
- Ready for coupling with an external vacuum cleaner.
- Cutting depth regulator.
- Bevel cuts 45°.
- Ergonomic handles

Included:
- Cutting guide
- Widia disc ø190 x 30 mm

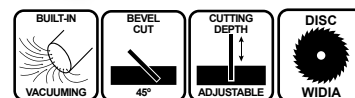

PLANER

PH 82 C

Cod. 1.2585

Power	710	W
No load speed	17000	rpm
Routing depth	0 - 2	mm
Depth levels	10	
Planing width	82	mm
Weight	2.4	kg

- Powerful planer with transmission belt motor
- Depth regulator by quarters of millimeter
- Powerful Built-in vacuuming system.
- Ready for coupling with an external vacuum cleaner.
- Quick blade change

Included:
- Lateral guide
- Dust collecting bag
- Blade set

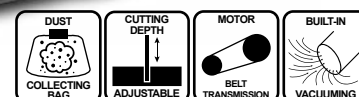



JIG SAW

JS 55 CE

Cod. 1.2782

Power	500	W
No load speed	0 - 3000	rpm
Max. cut wood	55	mm
Max. cut steel	3	mm
Max. cut aluminum	6	mm
Weight	2	kg

- Quick blade change. T insertion
- Bevel cuts 0 a 45°
- Electronic speed regulator
- Ready for coupling with an external vacuum cleaner

Included:

- Lateral guide
- x1 Saw for wood
- x1 Saw for metal

NEW
Check availability

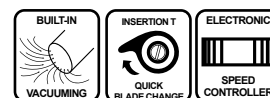

JIG SAW

JS 80 BPE

Cod. 1.2722

Power	650	W
No load speed	500 - 3000	rpm
Max. cut wood	80	mm
Max. cut steel	8	mm
Max. cut aluminum	22	mm
Weight	2.1	kg

- Quick blade change. T insertion
- Pendular cutting. 3 levels
- Bevel cuts 0 a 45°
- 6 levels electronic speed regulator
- Ready for coupling with an external vacuum cleaner

Included:

- Lateral guide
- x1 Saw for wood
- x1 Saw for metal

NEW
Check availability



MULTI TOOL

MULTIDRILL 130

Cod. 1.651

Power	130	W
No load speed	8000 - 33000	rpm
Insertion	ø32	mm
Weight	0.5	kg

- Great precision multi tool
- Electronic speed regulator
- For all kind of materials
- Suitable for a great range of accessories. Insertion ø32 mm
- For drilling, sanding polishing, cutting & milling

Included:

- Extensible flexible shaft 110 mm.
- 200 Accessories

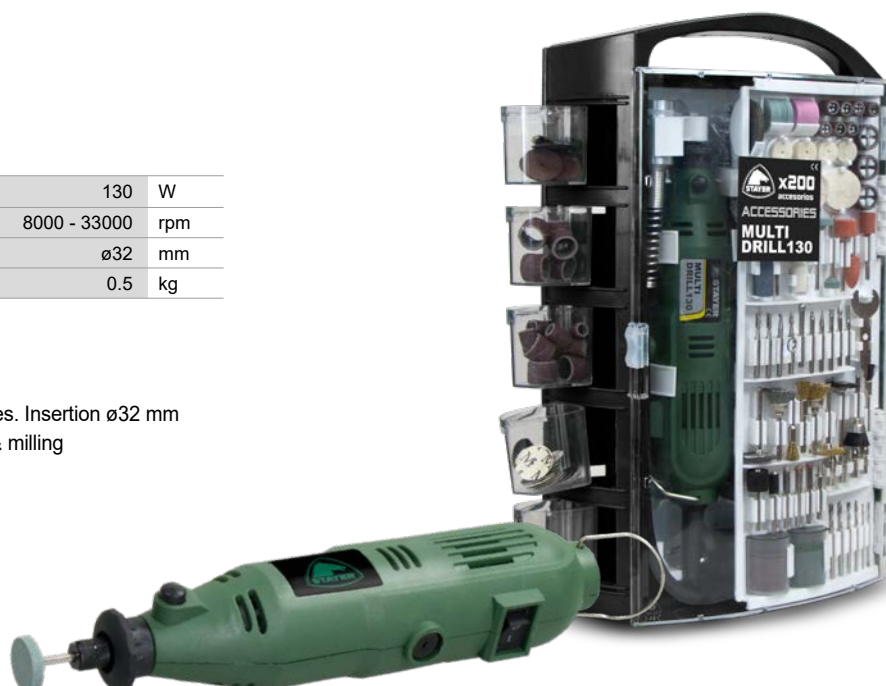

BENCH GRINDER

E 150 C

Cod. 2.534



Power	150	W
No load speed	2950	rpm
Grinding wheel	ø150 x 16 x 12.7	mm
Weight	5.7	kg

- **Powerful induction motor class E**
- Sealed ball bearings.
- Solid cast housing.
- Adjustable workpiece supports
- Transparent protectors against projections

Included:

- x1 Grinding wheel ø150 mm A36
- x1 Grinding wheel ø150 mm A60



BENCH GRINDER

EP 200 BM

Cod. 2.402



Power	350	W
No load speed	2950	rpm
Grinding wheel	ø200 x 20 x 16	mm
Weight	11.5	kg

- **Powerful flat curve motor over bearings**
- **Motor Dust protection sealing**
- Sealed ball bearings.
- Electromagnetic antidust switch.
- Adjustable workpiece supports
- Transparent protectors against projections

Included:

- x1 Grinding wheel ø200 mm A36
- x1 Grinding wheel ø200 mm A60



COMBINED BENCH GRINDERS

ECA 150 B

Cod. 2.404



- **Bench grinder & Sharpener**
- **Powerful flat curve motor over bearings. Dust protection sealing**
- Electromagnetic antidust switch.
- Adjustable workpiece supports
- Transparent protectors against projections

Included:

- x1 Grinding wheel ø150 mm
- x1 Sharpening grinding wheel (wet/dry) ø200 mm

Power	350	W
No load speed	2950	rpm
Grinding wheel	ø150 x 20 x 12.7	mm
Sharpening wheel	ø200 x 40 x 20	mm
Weight	8.5	kg

ECP 150 B

Cod. 2.403



- **Bench grinder & Brush**
- **Powerful flat curve motor over bearings. Dust protection sealing**
- Electromagnetic antidust switch.
- Adjustable workpiece supports
- Transparent protectors against projections

Included:

- x1 Grinding wheel ø150 mm
- x1 Cepillo ø150 mm

Power	350	W
No load speed	2950	rpm
Grinding wheel	ø150 x 20 x 12.7	mm
Brush	ø150	mm
Weight	7	kg

ECL 150 B

Cod. 2.405



- **Bench grinder & Belt sander**
- **Powerful flat curve motor over bearings. Dust protection sealing**
- Electromagnetic antidust switch.
- Adjustable workpiece supports
- Transparent protectors against projections

Included:

- x1 Grinding wheel ø150 mm
- x1 Sanding sheet belt 50 x 686 mm.

Power	350	W
No load speed	2950	rpm
Grinding wheel	ø150 x 20 x 12.7	mm
Belt sanding sheet	50 x 686	mm
Weight	10	kg



HOT AIR GUN

SUH 2000 E

Cod. 1.380

SUH 2000 EK

Cod. 1.5786

Power	2000	W
Airflow	250 - 450	l/min
Temperature	50 - 450 / 90 - 600	°C
Weight	0.9	kg

- Hot air gun with ceramic resistance
- Adjustable temperature & airflow.
- 2 workmodes
- Dries and peels varnish off. Folds plastic materials. Separates adhesive papers

SUH 2000 EK

Included:

- Nozzle set
- HD-PE Carry Case

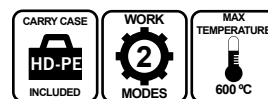

PAINT GUN

EPG 300

Cod. 1.738

Power	400	W
Spray pressure	0.1 - 0.2	Bar
Tank capacity	0.8	L
Feeding capacity	300	g/min
Max. viscosity	30	DIN/sec
Nozzle	ø2.5	mm
Weight	0.9	kg

- Compact paint gun
- Safety nozzle lock.
- Paint flow regulator
- Nozzle with 3 work modes
- Quick tool disassembly
- Viscosity regulator

Included:

- Nozzle

Optional:

Nozzle 1.80 mm for low viscosity paint.
Cod. 5015.192

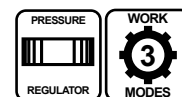

PAINT GUN

EPG 800

Cod. 1.2828

Power	800	W
Spray pressure	0.1 - 0.3	Bar
Tank capacity	900	ml
Feeding capacity	1100	ml/min
Max. viscosity	70	DIN/sec
Nozzle	ø2.5	mm
Weight	2.9	kg

- Compressor paint gun
- Paint flow regulator
- Nozzle with 3 work modes
- Viscosity regulator

Included:

- Nozzle
- Hose 1.8 m
- Carry band



NEW
Check availability



MINI COMPRESSOR

MINICOM B 12V

Cod. 1.2637

Voltage	12	V
No load speed	1200 - 1400	rpm
Max. Pressure	18	Kpa
Air Flow	30	l/min
Weight	0.5	kg

- Compact air compressor for cars
- Connection to the car lighter.
- Pressure gauge for maximum control.

Included:

- x3 Nozzles
- Cable 3m.



ASH CLEANER

BC 1200 D

Cod. 1.1072

Power	1200	W
Suction capacity	19	Kpa
Tank capacity	20	L
Hose size	ø38 x 1000	mm
Weight	4.5	kg

- Specially designed for stoves, chimneys, barbeques. Suitable for dust, leafs, sawdust.
- Metal tank with high thermic resistance.
- Heat resistant flexible hose.
- Aluminum nozzle resistant against abrasion and wear out.
- HEPA Filter with metal protection.

Included:

- Hose
- Aluminum nozzle
- HEPA Filter

Optional

- HEPA Filter + Filter cover (washable)
Cód. 8190.98

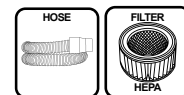

ELECTRIC CHAIN SAW

OLMO 22-400 B

Cod. 1.1119

Power	2200	W
No load speed	9000 - 13000	rpm
Cutting speed	13.5	m/s
Oil capacity	120	ml
Bar length	400	mm
Weight	5	kg

Included:

- Chain and bar.
- Chain cover
- Screwdriver & service key

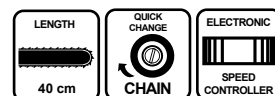



GENERATORS • CHAINSAWS
HIGH PRESSURE CLEANERS • PUMPS

HIGH PRESSURE CLEANER

HL 105 B

Cod. 1.2008

Power	1400	W
Speed	16300	rpm
Flow rate	5.5	l/min
Maximum flow rate	6.2	l/min
Max. Pressure	105	Bar
Work Pressure	70	Bar
Max. water input pressure	4	Bar
Protection	IPX5	
Weight	5.8	kg

- High pressure cleaner with S1 constant service motor.
- Total Sop System (TSS). Automatically switches off the pump when releasing the trigger to avoid tool damage.
- High pressure hose 5m.
- Cable 5 m.

Included:

- Gun with Safety switch lock.
- Turbo lance
- Vario power lance
- Connector
- Water filter



HIGH PRESSURE CLEANER

HL 135

Cod. 1.3321

Power	1600	W
Speed	16300	rpm
Flow rate	5.5	l/min
Maximum flow rate	7	l/min
Max. Pressure	135	Bar
Work Pressure	105	Bar
Max. water input pressure	5	Bar
Protection	IPX5	
Cable length	5	m
Hose	5	m
Weight	5.8	kg

- High pressure cleaner with S1 constant service motor.
- Total Sop System (TSS). Automatically switches off the pump when releasing the trigger to avoid tool damage.

Included:

- Gun with Safety switch lock.
- Turbo lance
- Vario power lance
- Connector
- Water filter



NEW
Check availability

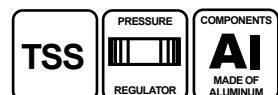



HIGH PRESSURE CLEANER

HLC 2000

Cod. 1.1996

Power	2000	W
Speed	14500	rpm
Flow rate	6.7	l/min
Max. Pressure	150	Bar
Work Pressure	130	Bar
Max. water input pressure	4	Bar
Protection	IPX5	
Weight	8.8	kg

- High pressure cleaner with S1 constant service motor.
- Total Sop System (TSS). Automatically switches off the pump when releasing the trigger to avoid tool damage.
- Flow rate Water regulable.
- Built-in soap tank.
- High pressure hose 5m.
- Cable 5 m.

Included:

- Gun with Safety switch lock.
- Connector
- Set 3 Nozzles: Turbo / 90° / Fan
- Water filter

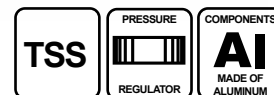

HIGH PRESSURE CLEANER

HL 2200

Cod. 1.3322

Power	2200	W
Speed	15000	rpm
Flow rate	6.5	l/min
Max. Pressure	160	Bar
Work Pressure	110	Bar
Max. water input pressure	5	Bar
Protection	IPX5	
Weight	8.7	kg

- High pressure cleaner with S1 constant service motor.
- Total Sop System (TSS). Automatically switches off the pump when releasing the trigger to avoid tool damage.
- Built-in soap tank.
- High pressure hose 5m.
- Built-in hose roll
- Cable 5 m.

Included:

- Gun with Safety switch lock.
- Turbo lance
- Vario power lance
- Water filter



NEW
Check availability

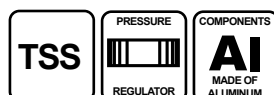

INDUSTRIAL HIGH PRESSURE CLEANER

HL 2700 B IND

Cod. 1.3323

Power	2500	W
Speed	2800	rpm
Flow rate	7.5	l/min
Max. Pressure	160	Bar
Work Pressure	140	Bar
Max. water input pressure	4	Bar
Protection	IPX5	
Weight	21.3	kg

New
Check availability

- High pressure cleaner with induction motor.
- Total Sop System (TSS). Automatically switches off the pump when releasing the trigger to avoid tool damage.
- Soap flow regulator.
- Integrated soap tank.
- High pressure hose 5m.
- 5 m. cable with integrated cable reel.

Included:

- Gun with Safety switch lock.
- Metal turbo lance
- Metal Vario power lance
- Water filter

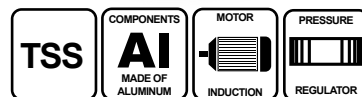

INDUSTRIAL HIGH PRESSURE CLEANER

HL 3000 IND

Cod. 1.1552

Power	3000	W
Speed	2800	rpm
Flow rate	9	l/min
Max. Pressure	200	Bar
Work Pressure	150	Bar
Max. water input pressure	7	Bar
Protection	IPX5	
Weight	25	kg

- High pressure cleaner with induction motor.
- Brass pump
- Total Sop System (TSS). Automatically switches off the pump when releasing the trigger to avoid tool damage.
- Built-in soap tank.
- High pressure hose 5m.
- Cable 5 m. with Built-in cable roll.

Included:

- Gun with Safety switch lock.
- Connector
- Set 6 Nozzles
0° / 15° / 25° / 40° / Soap / Turbo
- Water filter

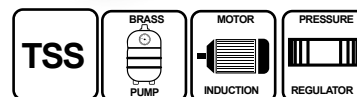



INDUSTRIAL HIGH PRESSURE CLEANER

HL 2000 PSI

Cod. 1.2410

Power	1800	W	1800	W
Speed	3400	rpm	3400	rpm
Flow rate	4.55	l/min	1.2	GPM
Max. Pressure	160	Bar	2300	PSI
Work Pressure	138	Bar	2000	PSI
Max. water input pressure	4	Bar	58	PSI
Protection	IPX5		IPX5	
Weight	18	kg	18	kg

- 110V Motor

- **Total Sop System (TSS).** Automatically switches off the pump when releasing the trigger to avoid tool damage.

- Built-in soap tank.
- Soap flow regulator.
- High pressure hose 6m.
- Cable 5 m.

Included:

- Gun with Safety switch lock.
- Metal turbo lance
- Metal Vario power lance
- Water filter

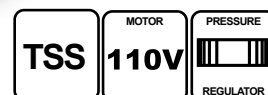

INDUSTRIAL HIGH PRESSURE CLEANER

HL 11 B IND

Cod. 1.2783

Power	2400	W
Speed	2800	rpm
Flow rate	10	l/min
Max. Pressure	200	Bar
Work Pressure	150	Bar
Protection	IPX5	
Weight	34	kg

- High pressure cleaner with powerful induction motor with copper wiring.

- Triple crankshaft brass pump

- Water pump with particle filter: extracts water from ponds, rivers and pools.

- Water pressure regulator.
- Motor temperature regulator.
- Great capacity soap tank.
- High pressure hose reinforced with steel 8m.
- Built-in cable roll.
- Built-in accessories housing.

Included:

- Gun with Safety switch lock.
- Connector
- Set 6 Nozzles
0° / 15° / 25° / 40° / Soap
- Water filter

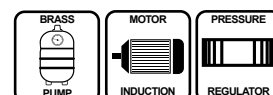

PRUNING GAS CHAIN SAW

OLMO G1 - 250 C

Cod. 1.2740

Power	0.9 / 1.2	Kw/HP
Cylinder capacity	25.4	cm ³
No load speed	3000	rpm
Tank capacity	260	ml
Oil capacity	160	ml
Bar length	250	mm
Weight	3.5	kg

- Light gas chain saw for 250 mm bars.
- 2 stroke motor.
- Specially designed for pruning tasks.
- Automatic and adjustable chain lubrication.
- Safety brake against recoils, obstructions & rebounds.
- Gas / oil mixture ratio 40:1
- Quick & easy chain tightening.
- Suitable for bars up to 450 mm.



- Included:**
- Chain and bar OREGON.
 - Bar cover
 - Mixture bottle 600 ml.
 - Screwdriver & service key

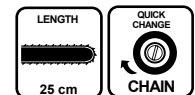

GAS CHAIN SAW

OLMO G2 - 400 B

Cod. 1.1042

Power	1.8 / 2.5	Kw/HP
Cylinder capacity	45	cm ³
No load speed	2800	rpm
Tank capacity	580	ml
Oil capacity	250	ml
Bar length	400	mm
Weight	5.5	kg

- Gas chain saw with 400 mm bar.
- 2 stroke motor.
- Automatic and adjustable chain lubrication.
- Visible oil level.
- Safety brake against recoils, obstructions & rebounds.
- Gas / oil mixture ratio 35:1
- Quick & easy chain tightening.
- Suitable for bars up to 450 mm.



- Included:**
- Chain and bar OREGON.
 - Bar cover
 - Mixture bottle 600 ml.
 - Screwdriver & service key

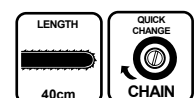

GAS CHAIN SAW

OLMO G3 - 450 C

Cod. 1.2741

Power	2.0 / 2.7	Kw/HP
Cylinder capacity	52	cm ³
No load speed	3000	rpm
Tank capacity	550	ml
Oil capacity	260	ml
Bar length	450	mm
Weight	6.5	kg

- Gas chain saw with 450 mm bar.
- 2 stroke motor.
- Automatic and adjustable chain lubrication.
- Safety brake against recoils, obstructions & rebounds.
- Gas / oil mixture ratio 40:1
- Quick & easy chain tightening.



- Included:**
- Chain and bar OREGON.
 - Bar cover
 - Mixture bottle 600 ml.
 - Screwdriver & service key

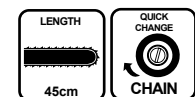

SEMI AUTOMATIC CHAIN SHARPENER

CS 85

Cod. 1.1356

Power	85	W
No load speed	6300	rpm
Disc	ø104 x 22.2 x 3.2	mm
Weight	2.5	kg

- Chain sharpener for all types of chain saws.
- Semi automatic system: the chain is secured with a clamp & can be moved automatically with a spring, but the clamp angle must be adjusted to use the sharpening disc.
- Chain clamp.
- Rotary clamp to adjust the sharpening angle.

Included:

- 3.2 mm sharpening disc



GAS BLOWER/VACUUM/SHREDDER

GAS VENTO 25 B

Cod. 1.2800

Power	0.7	Kw
Cylinder capacity	26	cm³
No load speed	3500 - 9000	rpm
Max. air speed	180	Km/h
Air flow rate	600	mm
Tank capacity	420	ml
Bag capacity	40	L
Weight	6	kg

- Gas blower / vacuum / shredder.
- Easy start in every situation.
- Telescopic tube for an easy transport and storage.
- Safety switch against unintentional triggerings.
- Ergonomic design with balanced mass.

Included:

- Dust bag
- Telescopic tube



NEW
Check availability

GAS HEDGE TRIMMER

GAS ROSE 710

Cod. 1.1354

Power	0.65	Kw
Cylinder capacity	22.5	cm³
No load speed	3000 - 7500	rpm
Blade length	600	mm
Tank capacity	600	ml
Weight	6.2	kg

- Gas hedge trimmer.
- Safety brake against recoils, obstructions & rebounds.
- Easy start in every situation.
- Safety switch against unintentional triggerings.
- Ambidextrous handle.
- Ergonomic design with balanced mass.

Included:

- Double blade protector



GAS BRUSH CUTTER
GAS CUTTER 33

Cod. 1.1549

Power	0.9	Kw
Cylinder capacity	33	cm ³
No load speed	3000	rpm
Thread cutting diameter	ø440	mm
Disc size	ø255	mm
Support size	ø26 x 1500	mm
Tank capacity	1	L
Weight	8	kg

- Gas brush cutter with disc and nylon thread roll.
- Powerful 2 stroke motor.
- High resistance aluminum
- Easy start in every situation.
- Automatic thread advance.
- Adjustable handle & telescopic support.
- Ergonomic design with balanced mass.



- Included:**
- Harness.
 - Nylon thread roll ø2.4 x 2500 mm.
 - 3 blade disc ø255 mm.
 - Protection carter.



3 blade disc



Automatic nylon Roll

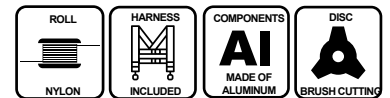

GAS BRUSH CUTTER
GAS CUTTER 43 B

Cod. 1.2713

Power	1.25	Kw
Cylinder capacity	42.7	cm ³
No load speed	3000	rpm
Thread cutting diameter	ø440	mm
Disc size	ø255	mm
Support size	ø26 x 1500	mm
Tank capacity	950	ml
Weight	6.8	kg

- Gas brush cutter with disc and nylon thread roll.
- Powerful 2 stroke motor.
- High resistance aluminum
- Easy start in every situation.
- Automatic thread advance.
- Gas / oil mixture ratio 40:1
- Adjustable handle & telescopic support.
- Ergonomic design with balanced mass.



- Included:**
- Double harness.
 - Nylon thread roll ø2.4 x 2500 mm.
 - 3 blade disc ø255 mm.
 - Protection carter.



Automatic nylon Roll

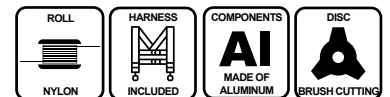

GAS BRUSH CUTTER / HEDGE TRIMMER / PRUNER
MULTIGAS CUTTER B

Cod. 1.2606

Power	0.75 / 1	Kw/HP
Cylinder capacity	33	cm ³
No load speed	3200	rpm
Thread cutting diameter	ø440	mm
Disc size	ø255	mm
Support size	1500 + 1000	mm
Tank capacity	0.8	L
Weight	12	kg

- Gas telescopic multi tool: Brush cutter with nylon thread & disc / Hedge trimmer / Pruner.
- Powerful 2 stroke motor.
- High resistance aluminum
- Easy start in every situation.
- Automatic thread advance.
- Adjustable handle & telescopic support.
- Ergonomic design with balanced mass.



- Included:**
- Double harness.
 - Nylon thread roll ø2.4 x 2500 mm.
 - 3 blade disc ø255 mm.
 - Pruner head
 - Hedge trimmer head
 - Telescopic support 1m.
 - Protection carter.



Pruner



Hedge Trimmer



3 Blade Disc





GENERATOR

GX 800

Cod. 1.2756

GENERATOR

Rated Voltage	230	V
Rated Current	3	A
Rated Power	0.65	KVA
Max. Power	0.8	KVA

MOTOR

Fuel	Unleaded gasoline	95°
Cylinder capacity	63	cc³
Starter	Manual	
Max. Power	2.0	HP
Tank capacity	4	L
Fuel / Oil ratio	50 : 1	
Autonomy	6	h
Noise level	98	dB(A)
Size	36 x 30.5 x 30.5	cm
Weight	16	kg
Outputs	x1 Monofásica	



- Safe connection to any kind of tool without damaging surges.
- Low consumption
- Voltage indicator.
- Output cable CC connection.

GENERATOR INVERTER

GID 2200 B

Cod. 1.2849

GENERATOR

Regulation	Stabilized Inverter 100%	
Rated Voltage	230	V
Rated Current	7.8	A
Rated Power	1.8	KVA
Max. Power	2.0	KVA
Output DC, Voltage	12	Vcc
Output DC, Amperes	8.3	A

MOTOR

Type	4T OHV	
Fuel	Unleaded gasoline	95
Cylinder capacity	79.7	cc³
Starter	Manual	
Max. Power	2.6	HP
Tank capacity	4	L
Oil capacity	350	ml
Autonomy	6	h
Noise level	62	dB (A)
Size	48 x 28.5 x 46	cm
Weight	18	kg
Outputs		



Full quality electricity
INVERTER SYSTEM
 Completely safe and stabilized

- Inverter output
- Safe connection to any kind of tool without damaging surges.
- Low consumption
- Low noise & vibration.
- Voltage indicator.
- Output cable CC connection.

- Included:**
- Output cable CC connection.
 - Spark plug replacement.
 - Screwdriver.
 - Spark plug wrench.
 - Tubo for drenar aceite.

SILENT INVERTER GENERATOR

GID 4000

Cod. 1.3341

GENERATOR

Rated Voltage	230	V
Rated Current	7.8	A
Rated Power	3.5	KVA
Max. Power	4.0	KVA
Output DC, Voltage	12	Vcc
Output DC, Amperes	8.3	A

MOTOR

Type	INVERTER	
Fuel	Unleaded gasoline	95
Cylinder capacity	223	cc³
Starter	Manual	
Max. Power	2.6	HP
Tank capacity	4	L
Oil capacity	350	ml
Autonomy	6	h
Noise level	62	dB (A)
Size	48 x 28.5 x 46	cm
Weight	18	kg
Outputs		

- Inverter output
- Safe connection to any kind of tool without damaging surges.
- Low consumption
- Low noise & vibration.
- Voltage indicator.
- Output cable CC connection.



GENERATORS AVR

GAV 2800 E

Cod. 1.1220

GAV 5500 E

Cod. 1.1221

GAV 7500 E

Cod. 1.1767

Safe Regulation
AVR
No Overvoltage



- AVR device that sets the output voltage.

- AVR sinusoidal output
- Safe connection to any kind of tool without damaging surges.
- Low consumption
- Voltage indicator.
- Output cable CC connection.
- Collapsible handle

Included:

- Output cable CC connection.
- Spark plug replacement.
- Screwdriver.
- Spark plug wrench.

GENERATOR	GAV 2800 E	GENERATOR	GAV 5500 E	GENERATOR	GAV 7500 E
Regulation	AVR	Regulation	AVR	Regulation	AVR
Rated Voltage	230 V	Rated Voltage	230 V	Rated Voltage	230 V
Rated Current	11 A	Rated Current	22 A	Rated Current	30 A
Rated Power	2.5 KVA	Rated Power	5 KVA	Rated Power	7 KVA
Max. Power	2.8 KVA	Max. Power	5.5 KVA	Max. Power	7.5 KVA
Output DC, Voltage	12 Vcc	Output DC, Voltage	12 Vcc	Output DC, Voltage	12 Vcc
Output DC, Amperes	4.2 A	Output DC, Amperes	8.3 A	Output DC, Amperes	8.3 A

MOTOR		
Type	4T OHV	
Fuel	Undeaded gasoline	95°
Cylinder capacity	196 cc ³	
Starter	Manual	
Max. Power	3.8 HP	
Tank capacity	15 L	
Oil capacity	0.6 L	
Autonomy	13 h	
Noise level	98 dB(A)	
Size	60 x 46 x 46.5 cm	
Weight	50 kg	
Outputs	x1 Monofásica	

MOTOR		
Type	4T OHV	
Fuel	Undeaded gasoline	95°
Cylinder capacity	389 cc ³	
Starter	Manual + Batería	
Max. Power	12 HP	
Tank capacity	25 L	
Oil capacity	1.1 L	
Autonomy	9 h	
Noise level	98 dB(A)	
Size	70 x 45 x 58 cm	
Weight	82 kg	
Outputs	x2 Monofásica	

MOTOR		
Type	4T OHV	
Fuel	Undeaded gasoline	95°
Cylinder capacity	458 cc ³	
Starter	Manual + Batería	
Max. Power	15 HP	
Tank capacity	25 L	
Oil capacity	1.1 L	
Autonomy	7 h	
Noise level	98 dB(A)	
Size	68 x 51 x 54 cm	
Weight	88 kg	
Outputs	x3 Monofásica	



INVERTER GENERATORS

GID 3500 OF

Cod. 1.3342

GID 4000 OF

Cod. 1.3343

GID 8000 OF

Cod. 1.3344

Valid for connection
to solar systems

NEW
Check availability



- Electronic output control for higher efficiency, precision and lower power consumption.

- Sine wave system to provide safe and high quality power.

- Safe connection to any type of device without harmful surges.
- Lower noise
- Lighter
- Higher efficiency
- Low power consumption
- Voltage indicator.
- Connector cable for DC output.

Included:

- Output cable CC connection.
- Spark plug replacement.
- Screwdriver.
- Spark plug wrench.

GENERATOR	GID 3500 OF		GENERATOR	GID 4000 OF		GENERATOR	GID 8000 OF	
Regulation	INVERTER		Regulation	INVERTER		Regulation	INVERTER	
Rated Voltage	230	V	Rated Voltage	230	V	Rated Voltage	230	V
Rated Current	8.3	A	Rated Current	8.3	A	Rated Current	8.3	A
Rated Power	3.2	KVA	Rated Power	3.6	KVA	Rated Power	7.2	KVA
Max. Power	3.5	KVA	Max. Power	4.0	KVA	Max. Power	8.0	KVA
Output DC, Voltage	12	Vcc	Output DC, Voltage	12	Vcc	Output DC, Voltage	12	Vcc
Output DC, Amperes	7.8	A	Output DC, Amperes	7.8	A	Output DC, Amperes	7.8	A

MOTOR

Type		
Fuel	Undeaded gasoline	95°
Cylinder capacity	223	cc ³
Starter	Manual	
Max. Power		HP
Tank capacity	7.5	L
Oil capacity	600	ml
Autonomy	3.5	h
Noise level		dB(A)
Size		cm
Weight	25.5	kg
Outputs		

MOTOR

Type		
Fuel	Undeaded gasoline	95°
Cylinder capacity	223	cc ³
Starter		
Max. Power		HP
Tank capacity	12.5	L
Oil capacity	600	ml
Autonomy	5	h
Noise level		dB(A)
Size		cm
Weight	35.5	kg
Outputs		

MOTOR

Type		
Fuel	Undeaded gasoline	95°
Cylinder capacity	458	cc ³
Starter		
Max. Power		HP
Tank capacity	20	L
Oil capacity	1100	ml
Autonomy	8	h
Noise level		dB(A)
Size		cm
Weight	60	kg
Outputs		

CLEAN WATER PUMPS

CWP 400

Cod. 1.2860

Power	400	W
Max. pumping rate	7300	L/h
Max. head	7.5	m
Max. depth	7	m
Cable	10	m
Weight	4	kg

- **Submersible water pump with 400W motor for draining and pumping clean water up to 35°C.**
- Ideal for emptying swimming pools and pumping water from wells and springs. The pump is prepared both for punctual work and to be installed in a fixed point and to work in a stationary way.
- The pump is prepared to work either perched on the bottom of the water or suspended by the handle.
- Floating switch specially designed to activate and deactivate the pump automatically. As long as the switch floats above the pump, the pump will run continuously. When the water level drops, the switch lowers and deactivates the pump to prevent it from burning out.
- Capable of pumping water up to 7.5 m above the pump.
- Prepared to submerge and pump up to 7 m depth.
- Rotating pumping tube and equipped with different adapters for $\varnothing 25 / 33 / 38 / 48 / 48$ mm hoses to be able to adapt to different locations and all types of pipes and extraction hoses.
- 10m long cable to be able to connect the pump safely away from water.



DIRTY WATER PUMPS

DWP 750

Cod. 1.2861

Power	750	W
Max. pumping rate	12500	L/h
Max. head	8	m
Max. depth	7	m
Cable	10	m
Weight	4.6	kg

- **Submersible water pump with 750W motor for draining and pumping dirty water up to 35°C.**
- Specially designed for pumping water with sand, mud, debris and remains of leaves or plants.
- Ideal for emptying swimming pools and pumping water from wells and springs. The pump is prepared to work both for punctual work and to be installed in a fixed point and to work in a stationary way.
- The pump is prepared to work either perched on the bottom of the water or suspended by the handle.
- Floating switch specially designed to activate and deactivate the pump automatically. As long as the switch floats above the pump, the pump will run continuously. When the water level drops, the switch lowers and deactivates the pump to prevent it from burning out.
- Capable of pumping water 8 m above the pump.
- Prepared to submerge and pump up to 7 m depth.
- Rotating pumping tube and equipped with different adapters for $\varnothing 25 / 33 / 38 / 48 / 48$ mm hoses to be able to adapt to different locations and all types of pipes and extraction hoses.
- 10m long cable to be able to connect the pump safely away from water.



DWP 1100 INOX

Cod. 1.2862

Power	1100	W
Max. pumping rate	15000	L/h
Max. head	9.5	m
Max. depth	7	m
Cable	10	m
Weight	5.9	kg

- **Submersible water pump with 1100W motor for draining and pumping clean and dirty water up to 35°C.**
- Specially designed for pumping water with sand, mud, debris and debris of leaves or plants, its structure reinforced with stainless steel makes it especially resistant to adverse environments.
- Ideal for emptying swimming pools and pumping water from wells and springs. The pump is prepared to work both for punctual work and to be installed in a fixed point and to work in a stationary way.
- The pump is prepared to work either perched on the bottom of the water or suspended by the handle.
- Floating switch specially designed to activate and deactivate the pump automatically. As long as the switch floats above the pump, the pump will run continuously. When the water level drops, the switch lowers and deactivates the pump to prevent it from burning out.
- Capable of pumping water 9.5 m above the pump. Prepared to submerge and pump up to 7 m depth.
- Rotating pumping tube and equipped with different adapters for $\varnothing 25 / 33 / 38 / 48 / 48$ mm hoses to be able to adapt to different locations and all types of extraction tubes and hoses.
- 10m long cable to be able to connect the pump safely away from water.



See our range of accessories

STAYER



Drill accessories

40 Pcs set (Points & socket spanner)



Pcs	Length	Model	Code
7	50	1xPH1 / 2xPH2 / 1xPH3 / 1xPZ1 / 2xPZ2	12.667
28	25	1xPH1 / 2xPH2 / 1xPH3 1xPZ1 / 2xPZ2 / 1xPZ3 1xT10 / 1xT15 / 2xT20 / 2xT25 / 1xT30 / 1xT35 / 1xT40 1xH3 / 1xH4 / 1xH5 / 1xH6 1xSL3 / 1xSL4 / 1xSL5 / 1xSL6 1xS1 / 1xS2	
3	65	(Socket spanner) 6 / 8 / 10	
1	70	1xPH2	
1 Adaptor			



Hardened impact screwing bits - 24 Pcs set



Pcs	Length	Model	Code
5	90	3xPH2 / 2xPZ2	12.668
7	50	1xPH1 / 3xPH2 2xPZ2 / 1xPZ3	
7	25	1xPH1 / 2xPH2 / 1xPH3 1xPZ1 / 1xPZ2 / 1xPZ3	
3	48	(Socket spanner) 6 / 8 / 10	
1	60	Adaptor	
1	Quick change adaptor		

ADVANTAGES

- Hardened carbon steel bits for an improved friction and impact resistance.
- Specially designed for **Impact screwdrivers.**
- Magnetic quick adaptor included.



Screwdriver bits Bit set (Quick change adaptor) - 32 Pcs



Pcs	mm	Model	Code
30	25	1xPH1 / 2xPH2 / 1PH3	1.1064
		1xPZ1 / 2xPZ2 / 1xPZ3	
		1x SL3 / 1xSL4 / 1xSL5 / 1xSL6	
		Hex 1x 3 / 1x 4 / 1x5 / 1x6	
		2xT10 / 2xT15 / 2xT20 / 2xT25 / 2xT27 / 2xT30 / 2xT40	
1	25	Adaptor	
1		Quick change adaptor	

Bits & Socket spanner, Quick change adaptor - 28 Pcs set



Pcs	Length	Model	Code
20	25	1xPH1 / 2xPH2 / 1xPH3	12.669
		1xPZ1 / 2xPZ2 / 1xPZ3	
		1xH3 / 1xH4 / 1xH5	
		1xSL3 / 1xSL4 / 1xSL5 / 1xSL6	
		1xT10 / 1xT15 / 2xT20 / 2xT25 / 1xT27	
6	(Socket wrenches) 5 / 6 / 8 / 10 / 12 / 13		
1		Adaptor	
1		Quick change adaptor	



25 mm

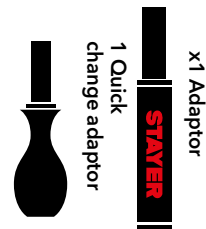
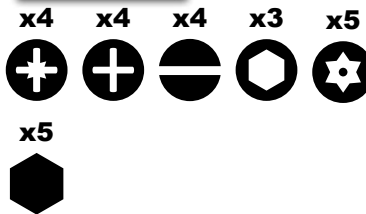

Adaptor



3 adaptor set to use socket spanners with drills and screwdrivers.

6 pcs

From	to	Code
	1/4"	12.670
1/4"	1/2"	
	3/8"	
with bearings		

Universal drill mount

- Neck 43 mm.
- Max length 68 mm.
- Tiltable 0-90°
- Weight 6.5 Kg
- SG 43 B



Code. 12.517

Set Impact socket wrench

Set of 4 socket wrenches 1/2".
Diameters 17/ 19/21/22 x81.5mmv



Code. 12.871

Flexible shaft



Cód. 12.590



70 Bits & tips set



70 Pcs set		Code
10 Bits - concrete	Ø 3,4,7,10 (x1) Ø 5,6,8 (x2)	1.1041
6 titanium steel drills	Ø 2,3,4,5,6,8	
10 Bits - concrete	Ø 3,4,5,6,8,10	
30 Screwdriving bits	25 mm	
10 screwdriver bits	50 mm	
Magnetic bit holder	60 mm	
Countersink bit	Ø 12.5	
2 Screw pincers		
3 Nut keys	Ø 6,7,8	
Medivdor		

Chucks



Zipper chuck
Ø 13 mm - 1/2" x 20

Code:
12.37



Automatic chuck
Ø 6 mm - 1/2" x 20
TM 6 BA

Code:
5014.235



Automatic chuck
Ø 13 mm - 1/2" x 20
TM 710 BA

Code:
12.508



Safety lock metal chuck
Ø 13 mm - 1/2" x 20
TM 950 A

Code:
12.536



Automatic chuck
Ø 10 mm - 3/8" x 24
TM 10 DA

Code:
8110.1559



Safety lock metal chuck
Ø 13 mm - 1/2" x 20
TM 750 BA / TM 851 A

Code:
12.26



Zipper chuck
Ø 16 mm - 5/8" x 16

Code:
220.98

Car set

Triple kit for car restoration to be used with a drill.

Its use requires electric or battery-powered drill.

Carefully read the instructions for use, step by step through the entire process using the appropriate sandpaper for each finish/job.

Recommended for use with 12-14-18V battery-powered screwdriver.



Lamp restoration

- Easy and fast scratch removal with great transparency recovery with sanding sheets P 800, 1200, 1500 & 2000.
- Finished with a special paste applied with sponge and rubber plate.
- Increases lamp sharpness for an increased driving security, significantly reducing fatigue.



Wheel tire restoration

- Conceals scratches using a polishing paste applied by sponge and rubber plate. Suitable for all types of wheel tires.



Bodywork restoration

- Conceals bodywork scratches no matter the car's color.
- Thanks to the restoration paste applied by sponge the bodywork recovers a brand new look.

Includes



Self adhering plate
shaft ø6 mm - Diameter ø75mm



Wool pad
for rubber plate



Sponge
for rubber plate



Sponge



x3 self adhering sanding
discs for bodywork
P240 / P360 P600



x4 self adhering sanding discs
for lamps
P800 / P1200 / P1500 / P2000



Microfiber cloth



100 ml tube
Tire paste



100 ml tube
Tire paste



100 ml tube
metal sheets paste

Code:
1.1923

Nylon cup brush



Brushes made of nylon filaments with aluminum oxide abrasive grains. It does not scratch or alter the dimensions of the pieces. Ø75mm Coarse grain.

USE
Cleaning and polishing.

Code:
12.868

Nylon circular flat brush



Filaments with great flexibility to avoid breakage and to penetrate all angles; it allows the brushing of irregular pieces extending the life of the brush. Ø75mm Coarse grain.

USE
For cleaning and polishing.

Code:
12.869

Masonry & concrete bits

5 bits set



ADVANTAGES

- '+' shaped head with 4 points for an increased resistance and longer lifespan.
- Nickel coating for a higher resistance with less abrasion.
- Tungsten carbide point.

Set	Ø (mm)	L(mm)	Code
1	5	90	11.5769
1	6	100	
1	8	110	
1	10	120	
1	12	130	

APPLICATIONS

Ceramic, masonry/concrete, bricks, Natural stone drilling.

USE

Cylindrical shank for drill use.

Bits case with tungsten carbide points



ADVANTAGES

- Tungsten carbide (widia) auto welded
- Longer lifespan
- Higher wear resistance
- Reduced vibration
- Greater dust removal due to the helical grooves
- Centering point Point to increase drilling precision and to avoid the bit sliding.

APPLICATIONS

Ceramic, masonry/concrete, bricks, Natural stone drilling.

USE

Cylindrical shank for drill use.



Pcs.	Ø(mm)	L(mm)	Code
1	4	90	12.734
1	5	100	
1	6	110	
1	8	120	
1	10	130	

Masonry bits

Vacuum brazed diamond bits for porcelanic



ADVANTAGES

- **VACUUM BRAZING** technology that improves the diamond grains retention, achieving a significant larger lifespan while increasing its heat resistance and abrasion wear
- Inner vegetal wax coating as lubricant to cool down the bit, reducing temperature, increasing its lifespan.
- Dry cut diamond bits, no water cooling needed.
- Perfect gres and porcelanic finish.

Ø.	Insertion	Code
5	HEX	5.1205
6	HEX	5.1171
8	HEX	5.1172
10	HEX	5.1173
x3 set		
6-8-10	HEX	5.1182

APPLICATIONS

Ceramic, gres, porcelanic, marble, granite drilling.

USE

Hex shank (1/4") for no impact drills

Before working it's advisable to mark the drilling zone with masking tape to avoid the bit sliding. This not mandatory as diamond drilling must be started with a 15-35° angle, and then drill with orbital movements. By doing this the bit wont slide and will last longer. Gate the drill speed according to the material to be drilled to extend the drill's lifespan.

If higher precision is required, we have a suction cup drilling guide with multiple hole diameters from 4 to 12 mm.

We also offer a cooling wax + angle grinder M14 adaptor set to increase the bit lifespan, while the adaptor enables your drill to use M14 angle grinder diamond cores.

Suction cup drilling guide for DRILLS

Adaptor



FEATURES

- Suction cup to attach the guide to multiple wall types.
- Ceramic, Gres, Gres Porcelanic, Glass, marble, metal.
- Hole metal coating for a reinforced protection.
- 4-5-6-7-8-10-12mm diameters.

Code
5.1191

FEATURES

- Angla grinder M14 vacuum brazed diamond cores adaptor to HEX for drill usage.
- Vegetal cooling wax for Ø5 - 6 - 8 - 10mm bits.



Code
5.1279

Glass & tiles lance bit set (5 Pcs)



ADVANTAGES

- Reinforced widia point that enables a higher precision and drilling speed.
- "U" shaped groove for an improved debris extraction, avoiding clogging.
- Cylindrical shank with 2 flat faces to improve the chuck retention.

APPLICATIONS

Glass and ceramic tiles drilling.

USE

Cylindrical shank with 2 flat faces to improve the chuck retention, no impact drilling.

Ø (mm)	Point	Code
x3 set		
3 x 6	TCT	12.711
1 x 8	Widia	
1 x 10		



Metal bits

RECOMMENDATIONS AND SAFETY GUIDELINES

- Use coolants when drilling metals to reduce excessive bit heating and extend its lifespan.
- Adapt your tool's speed according to the material to be drilled. The harder the material, less speed must be used.
- Use protection glasses to protect your eyes from metal debris. Use gloves, ear protection and a breathing mask.
- To perform big diameter holes it's advisable to start using a smaller bit first to improve the bigger bits performance avoiding accidental slides. The smaller bit diameter must be at least the same size than the minimum distance between the cutting edges from the bigger bit.
- When drilling on thin metal sheets, hold both sides with wood pieces to improve the grip while preventing the piece moving thus increasing the drilling quality.

10 Bits set, HSS-R, DIN 338, roll laminated, 118° tip



ADVANTAGES

- **Helical HSS bit** Made from high quality super fast steel DIN 338, **roll laminated**, right cutting, Type N, Cylindrical shank.
- **Sharpened bit tip with a 118° attack angle**, to improve the drilling quality on soft materials.
- Tensile strength **< 900 N/mm²**.
- Double spiral groove for an optimal **debris extraction**.
- High elasticity to reduce small diameter bits breaking.
- **Black oxide coating** to improve the cutting quality while increasing the bit s heat resistance.

APPLICATIONS

Specially suited to drill cast iron and steels with a hardness level up to 900 N/mm², non ferrous metals like aluminum, copper, brass, hard plastics and soft alloys.

USE

Use with a hand drill, bench drills with a 10 mm or more chuck.

Ø (mm)	Lt (mm)	Lu (mm)	Code
1	34	12	12.635
2	49	24	
3	61	33	
4	75	43	
5	86	52	
6	93	57	
7	109	69	
8	117	75	
9	125	81	
10	133	87	

10 Bits set, HSS-G, DIN 338, Rectified, 135° tip



ADVANTAGES

- **Helical HSS bit** Made from high quality super fast steel DIN 338, **rectified**, right cutting, Type N, Cylindrical shank.
- **Sharpened bit tip with a 135° attack angle**, improved drilling on hard materials increasing the drilling speed over beveled edge bits. Sharpened in accordance to DIN 1412 C.
- **Split Point** to avoid bit sliding while improving drilling quality.
- **Milled bit** for an optimal precision.
- Tensile strength **< 1000 N/mm²**.
- Double spiral groove for an optimal **debris extraction**.
- **Black oxide coating** to improve the cutting quality while increasing the bit s heat resistance.

APPLICATIONS

Specially suited to drill cast iron and steels with a hardness level up to 1000 N/mm², non ferrous metals like aluminum, copper, brass, hard plastics and medium alloys.

USE

Use with a hand drill, bench drills with a 10 mm or more chuck.

Ø (mm)	Lt (mm)	Lu (mm)	Code
1	34	12	12.636
2	49	24	
3	61	33	
4	75	43	
5	86	52	
6	93	57	
7	109	69	
8	117	75	
9	125	81	
10	133	87	



Split point
135° attack angle
Precise and fast drilling.

Avoids bit sliding over the material to be drilled

Metal bits

19 Bits se, HSS-Co, DIN 338, Rectified with cobalt, 135° tip



ADVANTAGES

- **Helical HSS-Co** made from high quality super fast steel alloyed with **5% Cobalt**, DIN 338, rectified, right cutting, Type N, Cylindrical shank.
- **Sharppened bit tip with a 135° attack angle**, improved drilling on hard materials increasing the drilling speed over beveled edge bits. Sharpened in accordance to DIN 1412 C.
- **Split Point** to avoid bit sliding while improving drilling quality.
- **Milled bit** for an optimal precision.
- Tensile strength **< 1200 N/mm²**.
- Double spiral groove for an optimal **debris extraction**.
- **Long lifespan**: Cobalt alloy significantly improves **heat and wear resistances**.

APPLICATIONS

Specially suited for **stainless steel drilling, alloyed and non alloyed steels** with a tensile strength up to 1200 N/mm², grey casting and steel casting.

USE

Use with a bench drill, **not suitable for hand drills due to the bits hardness**.

Ø (mm)	Lt (mm)	Lu (mm)	Code
1	34	12	12.637
1,5	40	18	
2	49	24	
2,5	57	30	
3	61	33	
3,5	70	39	
4	75	43	
4,5	80	47	
5	86	52	
5,5	93	57	
6	93	57	
6,5	101	63	
7	109	69	
7,5	69	69	
8	117	75	
8,5	117	75	
9	125	81	
9,5	125	81	
10	133	87	



Rectified cobalt bits



COBALT



SPLIT POINT

Split point
135° attack angle
Precise and fast drilling.
Avoids bit sliding over the material to be drilled



Pcs.	Ø (mm)	Lt (mm)	Lu (mm)	Code
1	1	34	12	12.638
1	1,5	40	18	12.639
1	2	49	24	12.640
1	2,5	57	30	12.641
1	3	61	33	12.642
1	3,5	70	39	12.643
1	4	75	43	12.644
1	4,5	80	47	12.645
1	5	86	52	12.646
1	5,5	93	57	12.647
1	6	93	57	12.648
1	6,5	101	63	12.649
1	7	109	69	12.650
1	7,5	109	69	12.651
1	8	117	75	12.652
1	8,5	117	75	12.653
1	9	125	81	12.654
1	9,5	125	81	12.655
1	10	133	87	12.656
1	11	141	93	12.657
1	12	149	99	12.658
1	13	157	105	12.659

Rectified cobalt bits - HSS M35

Bench drill special use

HSS M35 bits, 8% cobalt alloy, rectified, Split point with a 135° attack angle, 13mm reduced shank with 3 flat faces for an improved grip.

Pcs.	Ø (mm)	Lt (mm)	Lu (mm)	Code
1	14	160	108	12.847
1	15	169	114	12.848
1	16	178	120	12.849

Straight step bits, HSS Titanium coated

3 straight bits set, HSS titanium coated.

ADVANTAGES

- **Step HSS bit** made of high speed steel, **coated with titanium nitride.**
- **3 faced shank** to avoid chuck sliding.
- **The titanium nitride** significantly increases the bit **lifespan** allowing harder steel drilling.
- **Sharpened tip to improve drilling quality** on softer materials, without previous marking needed.
- **Double grooving** for a faster and softer drilling **with an improved debris removal.**
- We advise doing a previous smaller drilling before using this bit on harder materials.

APPLICATIONS

Suited for thin metal sheet drilling, non ferrous materials, steels, copper, brass, aluminum, PVC, glassfibre & wood.
3 faced Cylindrical shaft.

USE

Use with a hand drill, bench drills with a 10 mm or more chuck.



Case included				
Ø (mm)	N° steps	Shank	Lt (mm)	Code
4-6-8-10-12 14-16-18-20	9	3-sided	75	12.671
12-13-14-15-16 17-18-19-20	9	3-sided	75	
6-8-10-12-14-16- 18-20-22-24- 26-28-30	13	3-sided	95	



Spiral step HSS-M2 titanium coated bits

ADVANTAGES

- **HSS-M2 step drill bit** made of high speed steel, **coated with titanium nitride.**
- **3 faced shank** to avoid chuck sliding.
- **The titanium nitride** significantly increases the bit **lifespan** allowing harder steel drilling.
- **The titanium nitride** significantly increases the bit **lifespan** allowing harder steel drilling.
- **Sharpened tip to improve drilling quality** on softer materials, without previous marking needed.
- **Spiral grooving for an improved debris removal** reducing vibrations and increasing drilling speed.
- We advise doing a previous smaller drilling before using this bit on harder materials.



APPLICATIONS

Suited for thin metal sheet drilling, non ferrous materials, steels, copper, brass, aluminum, PVC, glassfibre & wood.
3 faced Cylindrical shaft.

USE

Use with a hand drill, bench drills with a 10 mm or more chuck.

Case included				
Pcs	Ø (mm)	N° steps	Lt (mm)	Code
1	4-6-8-10-12 14-16-18-20	9	75	12.672
1	6-8-10-12-14-16- 18-20-22-24-26- 28-30	13	95	12.673

Metal countersink bits

6 Countersink bits set for metal

ADVANTAGES

- Conic countersink bits DIN 335, shape C. 90° milling angle. Rectified hard metal HSS.
 - 3 flat faced Cylindrical shank to avoid chuck sliding.
 - Split point to improve precision, according to DIN 1412 C.
 - 118° cutting angle, right cutting. Optimal material removal, reducing noise, vibrations, increasing the bit lifespan.
 - Included bits: (6,3 - 8,3 - 10,4 - 12,4 - 16,5 - 20,5 mm)
- Suitable for non ferrous metals, steel, termoplastics and hard plastics as well as metal sheets up to 5mm thickness.

APPLICATIONS

Specially designed for metal sheets drilling, up to 5mm as well as non ferrous metals, steel and alloyed steel up to 1.000 N/mm², copper, brass, aluminum, PVC, Fiberglass & wood.

USE

Use with a hand drill, bench drills with a 10 mm or more chuck.



Ø (mm)	Description	Shank (mm)	Code
6,3	HSS 90°	3	12.674
8,3	HSS 90°	4	
10,4	HSS 90°	5	
12,4	HSS 90°	6	
16,5	HSS 90°	8	
20,5	HSS 90°	10	



8% cobalt bimetallic cores

Cores with centering bit for plumbing and electricism

ADVANTAGES

- Bimetallica saw cores with a 8% cobalt. This alloy increases the teeth resistance on harder materials, increasing the core lifespan. Allowing for long drilling sessions without teeth wearing out.
- Variable teeth alignment between 4 & 6 TPI (Teeth per inch), to ease the drilling.
- **Arbor and centering bit sold separately.**
- For great diameter hole boring. From 20 up to 76 mm. 38 mm cutting depth.

APPLICATIONS

Suitable for stainless steel drilling, steel and alloyed steel, cast metals, wood, plywood, plastics, drywall.



Uds	Ø (mm)	Code
1	20	12.720
1	22	12.721
1	25	12.722
1	32	12.723
1	35	12.724
1	40	12.725
1	51	12.726
1	60	12.727
1	64	12.728
1	76	12.729
1	102	12.851
1	121	12.852
1	152	12.853

USE

Use with a hand drill, bench drills once the core is attached to an arbor.



Arbors with spring and centering bit, HSS M2 high quality for bimetallic Cores.

Hex 3/8" insertion suitable for all chucks.

Spare centering bit HSS M2.

Ø (mm)	Code
6.35 x 75	12.733

Cores Ø (mm)		Code
14 - 30	Arbor & bit	12.730
32 - 210	Arbor & bit	12.731
14 - 30	SDS-PLUS	12.854
32 - 210	SDS-PLUS	12.855



Wood drill bits

Spiral bits

ADVANTAGES

- 3 points HSS spiral bits.
- Centering point with scaled cutter, for an improved cutting precision and drilling speed.
- Double spiral for an improved shavings removal.

APPLICATIONS

Suitable for all types of wood drilling.

USE

Use a hand drill. Cylindrical shank



Set	Ø (mm)	Lt (mm)	Insertion mm	Code.
5	4-5-6-8-10	75-152	47-102	12.760

Pcs	Ø (mm)	Lt (mm)	Insertion mm	Code
1	3	60	32	12.749
1	4	75	47	12.750
1	5	85	52	12.751
1	6	93	58	12.752
1	7	109	71	12.753
1	8	117	77	12.754
1	9	125	83	12.755
1	10	133	90	12.756
1	11	140	92	12.757
1	12	152	102	12.758
1	13	152	102	12.759

Spade bits

ADVANTAGES

- Flat spade bits made of reinforced carbon steel, for large diameter wood drilling.
- Centering point with double balde for an improved precision and cutting speed.
- Grooved edge to improve material removal while increasing the cutting speed.
- Diameters from 14 mm up to 32 mm.

APPLICATIONS

Suitable for all types of wood drilling.

USE

Use a hand drill or bench drill. Hex shank



Set	Ø (mm)	Lt (mm)	Insertion mm	Code
6	16-18-20-22-25-32	152	6.35	12.748

Pcs	Ø (mm)	Lt (mm)	Insertion (mm) HEX	Code
1	14	152	6.35	12.737
1	16	152	6.35	12.738
1	18	152	6.35	12.739
1	20	152	6.35	12.740
1	22	152	6.35	12.741
1	24	152	6.35	12.742
1	25	152	6.35	12.743
1	26	152	6.35	12.744
1	28	152	6.35	12.745
1	30	152	6.35	12.746
1	32	152	6.35	12.747

Salomonic bits (Lewis)

ADVANTAGES

- Hardened carbon steel bits, with centering tip and spiral groove.
- Specially designed for fast and precise deep through holes drilling.
- The bit spiral groove allows for an optimal sawdust extraction, greatly increasing the drilling speed.
- Auto drilling tip that significantly increases drilling on harder wood.
- Cutting blade placed from the tip to the spiral groove for clean and precise cuts.

APPLICATIONS

Suitable for all types of wood on woodworking and construction jobs.

USE

Hex shank for manual drills with a 13 mm chuck.



Pcs	Ø (mm)	Lt (mm)	Lu (mm)	Code
1	8	230	160	12.703
1	10	230	160	12.704
1	12	230	160	12.705
1	14	230	160	12.706
1	16	230	160	12.707
1	18	230	160	12.708
1	20	230	160	12.709

Hard metal Forstner bit for wood

ADVANTAGES

- Forstner bit with tungsten carbide teeth (widia).
- Great cutting speed and lifespan.
- Double cutting blade, centering point and two external cutting teeth for an optimal drilling on hard wood.



APPLICATIONS

Suitable for door hinge fitting.

USE

Cylindrical shaft for drills, bench drills and routers.

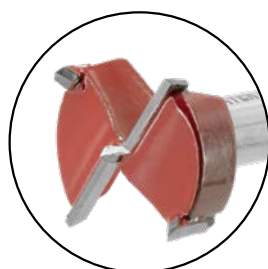

Pcs.	mm	Ø (mm)	Code
1	26	9	12.877
1	35	9	12.710

Wood countersink bits

ADVANTAGES

- HSS 3 Point spiral bits with centering tip and scaled blade for a precise and fast cut. Double spiral groove to improve sawdust removal.
- The countersink may be used as a depth regulator.
- Allows 6 - 8 & 10 mm countersinking.

APPLICATIONS

Suitable for drilling and countersinking on all types of wood.

USE

Cylindrical shaft for manual drill.



Set	Ø (mm)	Code
3	6, 8, 10	12.735





SDS PLUS (PRO4) Bits

ADVANTAGES

- High quality hardened steel with tungsten carbide tip.
- 4 tips "X" shaped point **to improve the bit's resistance and lifespan**, allowing reinforced concrete drilling without getting stuck like conventional drill bits do.
- Centering point to improve the drilling precision.
- Double channel spiral grooves for an optimal dust extraction, reducing the bit's abrasion while increasing the drilling speed.
- Optimal welded point to increase it's resistance increasing its lifespan while decreasing drilling vibrations.

APPLICATIONS

For masonry, concrete and reinforced concrete.

Compatible with every drill and hammer with an SDS PLUS insertion.



4 Puntas



Ø x Lt x Lu

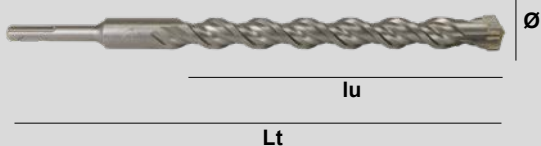

Ø: (Diameter)
Lt: Total length.
lu: Use length.

Ø (mm)	Lt (mm)	Lu (mm)	Code
5	110	50	11.5703
6	110	50	11.5436
7	110	50	11.5840
8	110	50	11.5437
9	110	50	11.5841
10	110	50	11.5438

Ø (mm)	Lt (mm)	Lu (mm)	Code
5	160	100	11.5704
6	160	100	11.5439
7	160	100	11.5842
8	160	100	11.5440
9	160	100	11.5843
10	160	100	11.5441
11	160	100	11.5844
12	160	100	11.5442
14	160	100	11.5852

Ø (mm)	Lt (mm)	Lu (mm)	Code
6	210	150	11.5443
8	210	150	11.5705
10	210	150	11.5706
12	210	150	11.5707
14	210	150	11.5444
16	210	150	11.5445

Ø (mm)	Lt (mm)	Lu (mm)	Code
8	260	200	11.5895
10	260	200	11.5896
12	260	200	11.5897
14	260	200	11.5898
16	260	200	11.5899

Ø (mm)	Lt (mm)	Lu (mm)	Code
10	310	250	11.5708
12	310	250	11.5709
14	310	250	11.5710
16	310	250	11.5711
18	310	250	11.5712
20	310	250	11.5713
22	310	250	11.5714
25	310	250	11.5715

Ø (mm)	Lt (mm)	Lu (mm)	Code
10	450	400	11.5446
12	450	400	11.5447
14	450	400	11.5448
16	450	400	11.5449
18	450	400	11.5450
20	450	400	11.5451
22	450	400	11.5452
25	450	400	11.5453

SDS PLUS (PRO 4) 5 bits set



Pcs	Ø (mm)	Lt (mm)	Lu (mm)	Code
5	5-6-8-10-12	110-160	50-110	11.5935

Pcs	Ø (mm)	Lt (mm)	Lu (mm)	Code
5	5	110	50	11.5739
5	6	110	50	11.5740
5	5	160	100	11.5741
5	6	160	100	11.5742
5	8	160	100	11.5743
5	10	160	100	11.5744

SDS MAX (PRO4) Bits

ADVANTAGES

- High quality hardened steel with tungsten carbide tip.
- 4 tips "X" shaped point **to improve the bit's resistance and lifespan**, allowing reinforced concrete drilling without getting stuck like conventional drill bits do.
- Centering point to improve the drilling precision.
- Double channel spiral grooves for an optimal dust extraction, reducing the bit's abrasion while increasing the drilling speed.
- Optimal welded point to increase it's resistance increasing its lifespan while decreasing drilling vibrations.

APPLICATIONS

For masonry, concrete and reinforced concrete.
Compatible with every drill and hammer with an SDS MAX insertion.

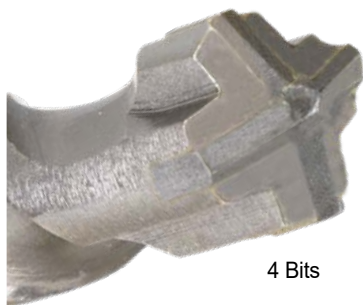

4 Bits

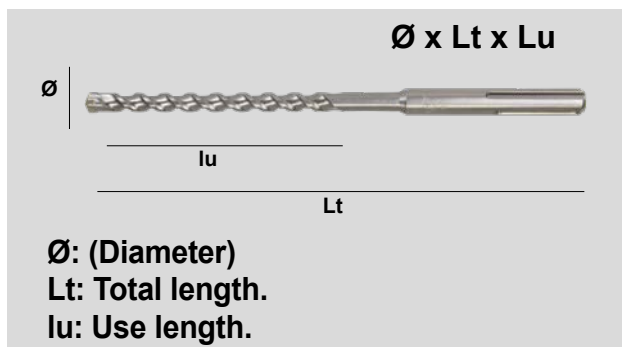

Ø (mm)	Lt (mm)	Lu (mm)	Code
16	260	140	11.5429

Ø (mm)	Lt (mm)	Lu (mm)	Code
12	340	200	11.5454
14	340	200	11.5455
16	340	200	11.5456
18	340	200	11.5457
20	340	200	11.5458
22	320	200	11.5900
24	320	200	11.5901
25	320	200	11.5902

Ø (mm)	Lt (mm)	Lu (mm)	Code
14	380	260	11.5432
18	380	260	11.5433
20	380	260	11.5431
22	380	260	11.5428
26	380	260	11.5430
28	380	260	11.5434
32	380	260	11.5427

Ø (mm)	Lt (mm)	Lu (mm)	Code
12	540	400	11.5459
14	540	400	11.5460
16	540	400	11.5461
18	540	400	11.5462
20	520	400	11.5463
22	520	400	11.5464
25	520	400	11.5465

Ø (mm)	Lt (mm)	Lu (mm)	Code
18	600	450	11.5466
20	600	450	11.5467
22	600	450	11.5468
25	600	450	11.5469
28	600	450	11.5470
30	600	450	11.5471
32	600	450	11.5472
35	600	450	11.5473
40	600	450	11.5474
45	600	450	11.5961
50	600	450	11.5962

Ø (mm)	Lt (mm)	Lu (mm)	Code
18	1000	833	11.5964
20	1000	833	11.5965
22	1000	833	11.5966
25	1000	833	11.5967
32	1000	833	11.5968
38	1000	833	11.5969



SDS PLUS / SDS MAX Chisels and Pointers

ADVANTAGES

- High quality tempered steel with hardening treatment to reduce wear and increase the tool's lifespan.
- Greater power and demolition speed.
- Greater material removal performance to increase the tool's lifespan.



APPLICATIONS

Refurbish and restoration jobs on masonry, concrete, bricks, floor and wall tiles. Compatible with every **SDS PLUS insertion hammer**.

Model	Width	Length	Code
Auto sharpening pointer	-	280	12.561
Auto sharpening chisel	25	280	12.562
Auto sharpening chisel	20	250	12.623
Spade chisel	40	250	12.398
Groover	14	250	12.393



ADVANTAGES

- High quality tempered steel with hardening treatment to reduce wear and increase the tool's lifespan.
- Greater power and demolition speed.
- Greater material removal performance to increase the tool's lifespan.

APPLICATIONS

Refurbish and restoration jobs on masonry, concrete, bricks, floor and wall tiles. Compatible with every **SDS MAX insertion hammer**.

Model	Width	Length	Code
Auto sharpening pointer	-	400	12.563
Auto sharpening pointer	-	600	12.736
Auto sharpening chisel	25	400	12.564
Auto sharpening chisel	25	600	12.388
Spade chisel	50	400	12.396
Spade chisel	80	400	12.397
Bricks groover	32	300	12.394
Fins groover	35	380	12.395

Adaptor SDS PLUS / SDS MAX



	Inch	Ø (mm)	Code
Chuck adaptor	1/2"	Ø 13	11.788



		Code
Adaptor	SDS MAX a SDS PLUS	11.4181

HEX 30 Chisels and Pointers



ADVANTAGES

- High quality tempered steel with hardening treatment to reduce wear and increase the tool's lifespan.
- Greater power and demolition speed.
- Greater material removal performance to increase the tool's lifespan.

APPLICATIONS

For refurbish and restoration jobs on masonry, concrete, bricks, floor and wall tiles. Compatible with every **HEX 30 insertion hammer**.

Model	Width	Length	Code
Auto sharpening pointer	-	400	12.260
Chisel	26	400	12.340
Spade chisel	80	400	12.341
Auto sharpening chisel	26	400	12.294

Drilling cores



ADVANTAGES

- High quality tempered steel with hardening treatment to reduce wear and increase the tool's lifespan. Great broing speed
- **Centering bit.**
- Reinforced widia teeth.

APPLICATIONS

Broing and drilling boring on masonry, concrete, bricks, floor and wall tiles.

Compatible with every **SDS PLUS insertion hammer**.

Core	∅ (mm)	Code
SDS-PLUS	40	11.5925
SDS-PLUS	60	11.5926
SDS-PLUS	80	11.5927



ADVANTAGES

- High quality tempered steel with hardening treatment to reduce wear and increase the tool's lifespan. Great broing speed
- **Centering bit.**
- Reinforced widia teeth.

APPLICATIONS

Boring and drilling on masonry, concrete, bricks, floor and wall tiles.

Compatible with every **SDS MAX insertion hammer**.

Core	∅ (mm)	Code
SDS-MAX	80	11.5928
SDS-MAX	100	11.5929
SDS-MAX	120	11.5930

Core axes



Core axes	Width	Length	Code
SDS-PLUS	24	200	11.5932
SDS-PLUS	24	330	11.5931
SDS-MAX	120	400	11.5936
Centering bit	8	110	11.5933

Sets SDS-PLUS



SDS-PLUS	Ø	mm	Code
7 masonry bits set	5,6,8	110	11.5757
	6,8,10,12	160	



13 SDS-PLUS bits set	Width Ø (mm)	Length	Code
Bits	6,8,10,12	160	11.5762
Bits	10,12,14,16	200	
Bits	10	260	
Chisel	20	250	
Spade	50	250	
Pointer	-	250	
Groover	-	250	

SDS-PLUS Bits stand









Stand + Bits

Code.
1.1269

Ø (mm) x L	Pcs	Code
5x110	10	11.5703
6x110	10	11.5436
8x110	10	11.5437
10x110	10	11.5438
6x160	10	11.5439
8x160	10	11.5440
10x160	10	11.5441
12x160	10	11.5442
10x210	6	11.5706
12x210	6	11.5707
14x210	6	11.5444
16x210	6	11.5445
10x310	6	11.5708
12x310	6	11.5709
14x310	6	11.5710
16x310	6	11.5711
18x310	6	11.5712
20x310	6	11.5713
22x310	6	11.5714
25x310	6	11.5715

Mixer whisks

Model	Tool	Description	Insertion	Ø (mm)	Code
-	-	Whisk (For drills)	Ø8	Ø80x40	11.5505
H2P	-	Paint and liquids Mixes from the top to the bottom	M14	Ø 100	12.445
H2		Liquid and low viscous materials Mixes from the bottom to the top	M14	Ø 120	12.231
H2		Liquid and low viscous materials Mixes from the bottom to the top	M14	Ø140	12.232
H2		Liquid and low viscous materials Mixes from the bottom to the top	M14 (detachable)	Ø140	12.485
H2		Liquid and low viscous materials Mixes from the bottom to the top	M14	Ø160	12.527
H3		All types of densities and viscosities Uniform mixing from the bottom to the top penetrating the material.	M14	Ø120	12.887
H3		All types of densities and viscosities Uniform mixing from the bottom to the top penetrating the material.	M14	Ø140	12.233
H3	-	For all densities and viscosities Evenly mixes the material from the bottom up and penetrates into the material.	M14	Ø160	12.234
H4	-	High density materials. Reduces the material heating.	M14	Ø114	12.235
T3	-	Combined spin whisk Increased mixing speed	M14	Ø170	12.444
WK3	DM1450	Combined rotating propeller Increased mixing speed	M18	Inf Ø95 Sup Ø120	12.538
-	DM1450	Combined spin helix adaptor	M18 - M14		12.295

Drill



H2P



H2



H3



H4



T3



WK3



Adaptor





Widia discs for circular saws

Wood

Standard

Widia discs with ATB teeth. Standard quality wood cutting

ø140 x 20 - Z24	Standard wood cutting. Reduction flange from 20 to 16 mm	2.171
ø150 x 20 - Z16	Standard wood cutting. Reduction flange from 20 to 16 mm	2.29
ø150 x 20 - Z24	Standard wood cutting. Reduction flange from 20 to 16 mm	12.318
ø160 x 20 - Z16	Standard wood cutting. Reduction flange from 20 to 16 mm	2.172
ø160 x 20 - Z24	Standard wood cutting. Reduction flange from 20 to 16 mm	2.173
ø165 x 20 - Z30	Standard wood cutting. Reduction flange from 20 to 16 mm	2.468
ø180 x 30 - Z24	Standard wood cutting. Reduction flange from 20 to 16 mm	2.174
ø180 x 30 - Z40	Standard wood cutting. Reduction flange from 30 to 20 & 16 mm	2.175
ø184 x 30 - Z24	Standard wood cutting. Reduction flange from 30 to 20 & 16 mm	2.176
ø184 x 30 - Z40	Standard wood cutting. Reduction flange from 30 to 20 & 16 mm	2.177
ø190 x 30 - Z24	Standard wood cutting. Reduction flange from 30 to 20 & 16 mm	2.146
ø190 x 30 - Z40	Standard wood cutting. Reduction flange from 30 to 20 & 16 mm	2.178
ø200 x 30 - Z40	Standard wood cutting	2.30
ø200 x 30 - Z64	Standard wood cutting	2.204
ø205 x 30 - Z24	Standard wood cutting	2.137
ø205 x 30 - Z30	Standard wood cutting	2.216
ø205 x 30 - Z40	Standard wood cutting	12.65
ø205 x 30 - Z54	Standard wood cutting	12.66
ø205 x 30 - Z60	Standard wood cutting	2.217
ø210 x 30 - Z24	Standard wood cutting	12.229
ø210 x 30 - Z48	Standard wood cutting	12.230
ø230 x 25.4 - Z24	Standard wood cutting	2.192
ø230 x 30 - Z48	Standard wood cutting	2.218
ø235 x 30 - Z24	Standard wood cutting	2.147
ø235 x 25.4 - Z24	Standard wood cutting	2.479
ø250 x 30 - Z48	Standard wood cutting	2.34
ø250 x 30 - Z60	Standard wood cutting	12.179
ø254 x 30 - Z40	Standard wood cutting	12.98
ø254 x 30 - Z60	Standard wood cutting	12.97
ø254 x 30 - Z80	Standard wood cutting	2.205
ø300 x 30 - Z48	Standard wood cutting	2.42
ø300 x 30 - Z72	Standard wood cutting	2.46
ø305 x 30 - Z48	Standard wood cutting	12.323
ø315 x 30 - Z36	Standard wood cutting. Anti nails disc	4006.59

Disc ATB Wood



ATB teeth
alternate upper
bevel



Semi silent disc

HQ

Widia discs with ATB teeth. HQ quality wood cutting

ø250 x 30 - Z48	HQ wood cutting	2.149
ø250 x 30 - Z60	HQ wood cutting	2.148
ø254 x 30 - Z60	HQ wood cutting	2.206
ø254 x 30 - Z80	HQ wood cutting	12.311
ø260 x 30 - Z80	HQ wood cutting	12.322
ø300 x 30 - Z72	HQ wood cutting	2.209
ø305 x 30 - Z96	HQ wood cutting	12.107
ø315 x 30 - Z72	HQ wood cutting	2.210
ø350 x 30 - Z108	HQ wood cutting	12.41

HQ Semi-silent

Semi silent widia discs with ATB teeth for wood cutting

ø235 x 30 - Z24	HQ wood cutting. Semi-silent plate	2.472
ø250 x 30 - Z60	HQ wood cutting. Semi-silent plate	2.473
ø260 x 30 - Z80	HQ wood cutting. Semi-silent plate	2.474
ø300 x 30 - Z72	Standard wood cutting. Semi-silent plate	2.751
ø300 x 30 - Z96	Standard wood cutting. Semi-silent plate	2.752
ø305 x 30 - Z72	Standard wood cutting. Semi-silent plate	2.475
ø305 x 30 - Z96	Standard wood cutting. Semi-silent plate	2.476
ø315 x 30 - Z72	Standard wood cutting. Semi-silent plate	2.493

Widia discs for circular saws

Laminated

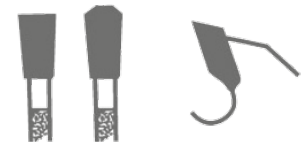

TCG teeth disc upper alternating bevel for laminate cutting

HQ & Semi silent HQ

Widia discs with TCG teeth for Laminate cutting

ø190 x 30 - Z48	HQ laminate cutting	2.489
ø210 x 30 - Z48	HQ laminate cutting	2.490
ø235 x 30 - Z48	HQ laminate cutting	2.491
ø254 x 30 - Z80	HQ laminate cutting. Semi-silent plate	2.486
ø305 x 30 - Z96	HQ laminate cutting. Semi-silent plate	2.487
ø315 x 30 - Z96	HQ laminate cutting. Semi-silent plate	2.494

Aluminum & Metal

Aluminum

Widia discs with TCG teeth for Aluminum cutting

ø200 x 30 - Z60	Standard aluminum cutting	2.120
ø205 x 30 - Z60	Standard aluminum cutting	12.315
ø210 x 30 - Z60	Standard aluminum cutting	2.138
ø250 x 30 - Z60	Standard aluminum cutting	2.36
ø250 x 30 - Z80	Standard aluminum cutting	12.42
ø300 x 30 - Z72	Standard aluminum cutting	2.49
ø305 x 30 - Z100	Standard aluminum cutting	2.220
ø250 x 30 - Z80	HQ aluminum cutting	2.154
ø254 x 30 - Z80	HQ aluminum cutting	12.258
ø300 x 30 - Z96	HQ aluminum cutting	12.43
ø300 x 30 - Z100	HQ aluminum cutting	12.326
ø300 x 30 - Z120	HQ aluminum cutting	12.411
ø305 x 30 - Z96	HQ aluminum cutting	12.259
ø350 x 30 - Z108	HQ aluminum cutting	12.45
ø250 x 30 - Z80	HQ aluminum cutting. Semi-silent plate	2.477
ø305 x 30 - Z96	HQ aluminum cutting. Semi-silent plate	2.478



TCG teeth disc upper alternating bevel for aluminum & metal cutting

Metal

Widia discs with TCG teeth for metal cutting

ø185 x 25.4 - Z48	HQ quality metal cut. Sandwich tooth. TD 185 disc -New	12.931
ø230 x 25.4 - Z48	Standard metal cutting for CP 236	12.399
ø235 x 25.4 - Z60	Standard metal cutting	12.592
ø305 x 25.4 - Z60	HQ metal cutting	12.63
ø355 x 25.4 - Z80	HQ metal cutting	75.288
ø355 x 25.4 - Z72	HQ metal cutting. Sandwich teeth for TD 355 B-New*	12.660



TCG teeth disc upper alternating bevel for aluminum & metal



METAL CUTTING

TCG Widia Disc Sandwich teeth

Ø 355 x 3.0 x 25.4 mm Z72

Cod. 12.660

Over 10 times better performance over other widia discs

Sandwich Panel

Widia MTCG Trapezium tooth blades Sandwich panels cutting

ø165 x 2.0 - Z30	Sandwich panel cutting. New*	2.816
ø190 x 2.0 - Z36	Sandwich panel cutting. New*	2.814
ø235 x 2.2 - Z50	Sandwich panel cutting. New*	2.817
ø300 x 2.2 - Z72	Sandwich panel cutting. New*	2.818



Circular saw discs

Multimaterial discs



MULTI MATERIAL discs

Wood, plastic, wood with nails, plaster cutting.
Tungsten particle blade.

Perfect finish cuts on laminate.

Tool	Ømm	Code
	Ø 115 x 22.2	2.442
	Ø 125 x 22.2	2.455

HSS Discs



HSS discs

Specially designed for fast wood cutting.

Tool	Ømm	Grain	Code
	Ø 115 x 2 x 22.2	Z-4	2.196
	Ø 125 x 2 x 22.2	Z-4	2.197
	Ø230 x 2 x 22.2	Z-4	2.198

Polycrystalline diamond discs



TCT Widia





Polycrystalline diamond

Polycrystalline Diamond Plate (PCD)

40 to 150 times higher performance than hard metal

Application

Furnitures / Coated or lacquered Doors and boards / Laminated parquet / MDF pieces (DM) whether or not coated / Soft and postforming

Ø	Ø	Segment thickness (mm)	Plate thickness (mm)	N° teeth (Z)	Code	
	115	22.2	1.7	1.2	Z-4	12.522
	125	22.2	1.7	1.2	Z-4	12.523
	190	30	1.7	1.2	Z-12	12.569

Ø 115 mm Disc
Z-4 (Z=teeth quantity)

Specially suited for Ø125 mm circular saws (CP 125)

“ The cutting geometry of the polycrystalline diamond guarantees a clean cut and much better performance than traditional discs. Reduces dust and sawdust. ”

Milling cutter for wall chaser



Channel width 25mm
Diameter Ø78mm

Code: 12.597

Hard metal burrs

3 Pcs Metal burrs



3 **hard metal burrs** for die grinders and drills (Mx according to DIN 8033)

- Cylindrical burr
 - Ball burr
 - Ojive burr
- ø6mm shank.

Cross serrated surface (double edge).

Roughing and **metal chips removal**, edges, **welding cords roughing, casting, tempered steel, hard plastics, Nickel alloys & titanium.**

Ø x Lu (mm)	Shank Ø (mm)	Lt (mm)	Code
12x25	6	70	1.2365
12x10.8	6	55	
12x25	6	70	

5 Pcs Metal burrs



5 **hard metal burrs** for die grinders and drills (Mx according to DIN 8033)

- Front cylindrical burr
 - Round cylindrical burr
 - Ball burr
 - Ojive burr
 - Conic burr
- ø6mm shank.

Cross serrated surface (double edge).

Roughing and **metal chips removal**, edges, **welding cords roughing, casting, tempered steel, hard plastics, Nickel alloys & titanium.**

5 Pcs set			
Ø x Lu (mm)	Shank Ø (mm)	Lt (mm)	Code
12x25	6	70	1.2364
12x25	6	70	
12x25	6	70	
12x25	6	70	
12x10.8	6	55	

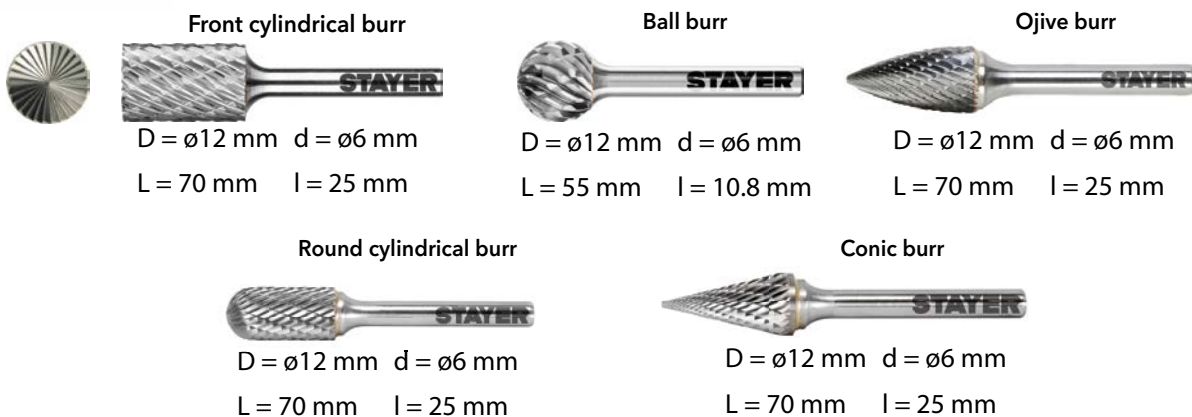

Brass brushes

3 pcs brush set

Cód.:
12.46



SILICON CARBIDE DISCS

Silicon carbide discs available in ø115 and ø125 mm for metal cleaning, removal of rust and paint as well as burrs. Particularly suitable for preparing metals for welding, anodizing or zinc plating.

Compatible with all types of grinders with M14 insert. Clamping nut is required.

Ø (mm)	Code
115 x 22	12.860
125 x 22	12.861







Reciprocating saw blades

* Set of 3 HCS wood and pruning saws

Code:12.629



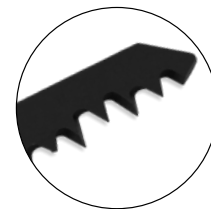

Icons	Pcs	Description	Applications	Size
 	3	HCS. Rectified, side-set teeth. Fast cutting.	Wood <190mm Plywood. Plastic Branches.	240x19x1.5



* Set of 3 HCS saws Wood and Plasterboard

Code:12.762



Icons	Pcs	Description	Applications	Size
  	3	HCS. Rectified, side-set teeth. Fine precision cut.	Wood (<100mm). MDF (<100 mm). Boards. Chipboard. Plywoods. PVC (<100 mm).	150x19x1.25

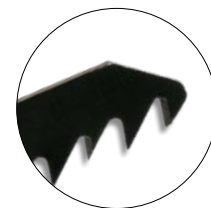



* Set 3 saws HCS Mixed Woo



Code:12.632

Includes adaptative fitting saw case





Icons	Pcs	Description	Applications	Size
 	1	HCS. Rectified, side-set teeth. Fast cutting.	Wood <190mm Plywood. Plastic Branches.	240x19x1.5



Icons	Pcs	Description	Applications	Size
 	1	HCS. Rectified, side-set teeth Progressive. Fine precision cut	Wood pannels (<175 mm). Construction wood(6-150 mm). Plywood. Chipboard. MDF (6-60 mm). PVC (6-150 mm).	200x19x1.25



Icons	Pcs	Description	Applications	Size
  	1	HCS. Rectified, side-set teeth. Fine precision cut.	Wood (<100mm). MDF (<100 mm). Boards. Chipboard. Plywoods. PVC (<100 mm).	150x19x1.25

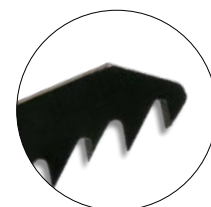

Reciprocating Saw blades



* Set 3 BIM Mixed Metal BIM Saws Code:12.631

Includes adaptative fitting saw case



Icons	Pcs	Description	Applications	Size
	1	BIM. Double sided milled teeth. Fast cutting & long lifespan	Thin metal sheets & thick (1-8 mm), Strong profiles (<100 mm)	150x19x0.9

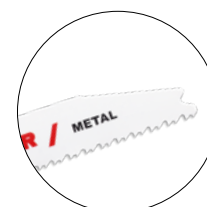

Icons	Pcs	Description	Applications	Size
	1	BIM. Double sided milled teeth. Fast cutting & flexible .	Thick metal sheets (3-8 mm). Profiles/pipes (<175mm).	225x19x0.9



Icons	Pcs	Description	Applications	Size
	1	BIM. Wave milled teeth. Thin metal sheets easy cut.	Thin metal sheets (0.7-3 mm) Thin profiles/pipes (<100mm)	150x19x0.9

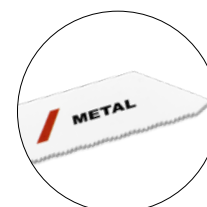

* Set 3 BIM Metal saws Code:12.763



Icons	Pcs	Description	Applications	Size
	3	BIM. Wave milled teeth. Thin metal sheets easy cut.	Thin metal sheets (0.7-3 mm) Thin profiles/tubes (<100mm)	150x19x0.9

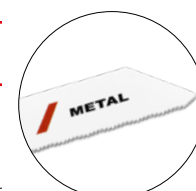





Reciprocating Saw blades

* Set 5 saws Cutting All Mixed Saws wood, plaster, plastic, metal

Code:12.630

Includes a storage case for convenient storage of all saws.



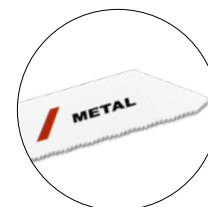

Icons	Pcs	Description	Applications	Size
 	1	BIM. Wave milled teeth. Fine clean cutting	Thin metal sheets (0.7-3mm). Thin profiles/pipes (<100mm). PVC.	150x19x0.9





Icons	Pcs	Description	Applications	Size
	1	BIM. Wave milled teeth. Special demolition cut, Straight and fast metal and wood cutting	Wood, Wood with nails, Chipboard (<100 mm), Fibreglass, Plastic/epoxy, Solid (<100 mm), Wall, wood, metal cutting (<100 mm)	150x22x1.6





Icons	Pcs	Description	Applications	Size
 	1	BIM. Side set milled teeth Special immersion cut Fast cutting wood & metal.	Wood, Wood with nails, Chipboard (10-100 mm), Fibreglass reinforcements & plastic, plastic/epoxy, Solid (8-50 mm), Drywall (<100 mm), Window frames: Wood & metal.	150x19x1.25



Icons	Pcs	Description	Applications	Size
 	1	HCS. Rectified, side-set teeth, Progressive. Fine precision cut	Wood pannels (<175 mm). Wood de Construction (6-150 mm). Plywood, Chipboard, MDF (6-60 mm). PVC (6-150 mm).	200x19x1.25



Icons	Pcs	Description	Applications	Size
 	1	HCS. Rectified, side-set teeth, Progressive. Fine precision cut	Wood Plywood Plastic	240x19x1.5

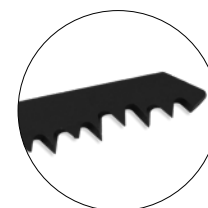

Reciprocating Saw blades

* Pallets (3 blades set)

Code:12.719



Icons	Pcs	Description	Applications	Size
	3	BIM. Rectified, side-set teeth 175mm cutting length Teeth spacing 3.2/5mm Demolition progressive teeth for fast cuts.	Wood with nails/ metal (Wood, Boards Chipboard) (<175mm). GFX/Epoxi, solid (<175mm). Demolition	225x22x1.6



* Frozen goods (3 blades set)

Code:12.500



Icons	Pcs	Description	Applications	Size
	3	Stainless steel	Frozen goods (10-250mm)	305x19x1.2



* Wood & Metal (Pallet special) TCT Teeth

Code:12.634



Icons	Pcs	Description	Applications	Size
	1	HM. Widia teeth. Rectified, side-set teeth Long lifespan. Demolition teeth, Progressive spacing for fast cuts.	Wood with nails/ metal (hardened) (5-175mm). Wood with steel (5-175mm) Cast steel tubes (Ø<6"). Fibreglass / epoxi (<175mm). Window frames metal/wood (<175mm)	225x50x1.5



Bricks y Fibrecement TCT teeth

Code:12.633



Icons	Pcs	Description	Applications	Size
	1	HM. Widia teeth. Long lifespan. Fast cutting on construction materials like bricks.	Medium bricks (< 215 mm) Poroton Fibrecement Porous concrete Red brick Construction stone	305x50x1.5





Jig Saw blades

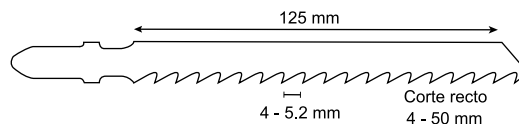

*** Set 5 HCS Wood ST 125 SF** Code:12.880

Icons	Pcs	Description	Applications	Size (mm)	TPI
	5	HCS. Fast cutting wood	Softwood (4-50mm)	125	4-5.2



*** Set 5 HCS Wood ST 125 FH** Code:12.881



Icons	Pcs	Description	Applications	Size (mm)	TPI
	5	HCS. Precise and clean cut soft wood	Softwood (3-30mm)	125	2.7



*** Set 5 HCS Hardwood ST 300 HF** Code:12.882



Icons	Pcs	Description	Applications	Size (mm)	TPI
	5	HCS. Precise cutting hardwood	Hardwood (10-65mm)	300	3



*** Set 5 BIM Wood ST 152 FH** Cod.:12.883



Icons	Pcs	Description	Applications	Size (mm)	TPI
	5	BIM. Fast cutting hardwood	Wood (5-100mm)	152	6

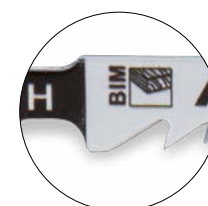

*** Set 5 HCS Wood ST 113 CC** Code:12.884



Icons	Pcs	Description	Applications	Size (mm)	TPI
	5	HCS. Curved cut laminated	Hardwood (1.5-15mm)	113	18



Jig Saw

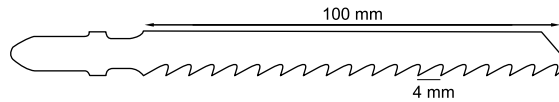

*** Set 10 Saws Wood, Metal and Aluminum**

Code:12.628



Icons	Pcs	Description	Applications	Size (mm)	TPI
ST125SF					
	2	HCS. Fast cutting of soft wood.	Wood	100	4

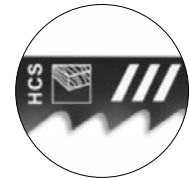

Icons	Pcs	Description	Applications	Size (mm)	TPI
ST101C					
	2	HCS. Curved wood cut.	Wood	82	2

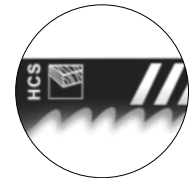

Icons	Pcs	Description	Applications	Size (mm)	TPI
ST114SC					
	2	HCS. Clean cut chipboard	Wood	100	2.5

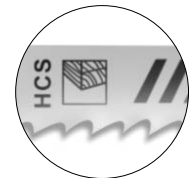

Icons	Pcs	Description	Applications	Size (mm)	TPI
ST207SC					
	2	HSS. Clean metal cutting	Metal	91	1.2



Icons	Pcs	Description	Applications	Size (mm)	TPI
ST208SF					
	2	HSS. Fast clean cut aluminum	Aluminum	100	3





Jig Saw

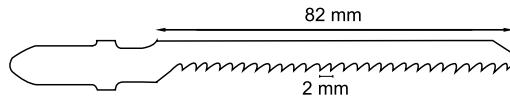

* Set 10 Wood Saws (Straight and Curved Cut)

Code:12.626



Icons	Pcs	Description	Applications	Size (mm)	TPI
	4	HCS. Clean cut	Wood	92	2

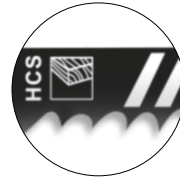

Icons	Pcs	Description	Applications	Size (mm)	TPI
	4	HCS. Fast cutting..	Wood	82	2



Icons	Pcs	Description	Applications	Size (mm)	TPI
	2	HCS. Curved cut	Wood	100	3

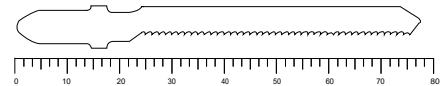
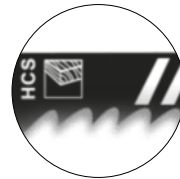

* Set 3 Metal Saws (Curved Cutting)

Code:12.624

Icons	Pcs	Description	Applications	Size (mm)	TPI
	3	HSS. Corte curvo	Thin sheet (1-3mm)	80	1.2

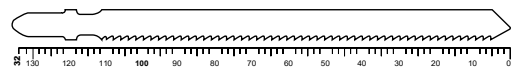
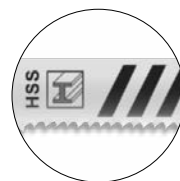

* Set 3 saws BIM Metal and Aluminum

Code:12.625

Icons	Pcs	Description	Applications	Size (mm)	TPI
	3	BIM. Bimetallic blades durable and breakage resistant to breakage. Straight and fast cutting.	Materials with fillers, aluminum, non-ferrous metals ferrous metals, epoxy	132	2

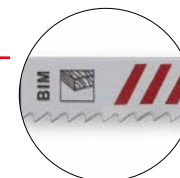

Jig Saw

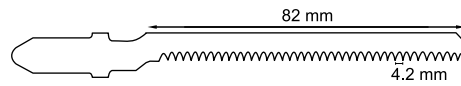

*** Set 10 hard/softwood saws**

Code:12.627



Icons	Pcs	Description	Applications	Size (mm)	TPI
	2	HCS. Fast cutting soft wood	Softwood (5-55mm)	100	4

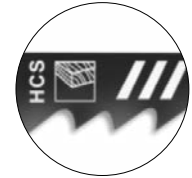

Icons	Pcs	Description	Applications	Size (mm)	TPI
	2	HCS. Curved cut chipboard	Softwood (5-55mm), Wood Chipboard	100	4

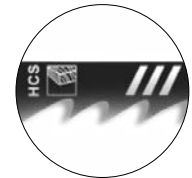

Icons	Pcs	Description	Applications	Size (mm)	TPI
	2	HCS. Fast cutting laminate and hardwood	Softwood (5-55mm), Chipboard	100	2.5

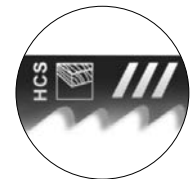

Icons	Pcs	Description	Applications	Size (mm)	TPI
	2	HCS. Clean cut agglomerate	Laminate, MDF, Plywood	82	4.2

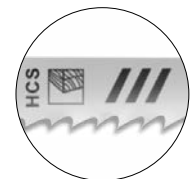

Icons	Pcs	Description	Applications	Size (mm)	TPI
	2	HCS. Curved cut clean laminated	Hardwood, Chipboard, Laminate, Plywood	100	4

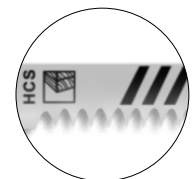

Bandsaw

Model	Description	Barcode 8427648	Code
SN 1435 B	Belt saw 1435 P 6/10	233751	2.267
SN 1435 B	Belt saw 1435 P 8/12	233768	2.268
SN 1435 B	Belt saw 1435 P 10/14	233775	2.269
SN 1470	Belt saw 1470x13x0.65mm P6/10	113428	2.130
SN 1470	Belt saw 1470x13x0.65mm P8/12	072398	2.117
SN 1470	Belt saw 1470x13x0.65mm P10/14	024991	12.117
SN 1735	Belt saw 1735x13x0.65mm P6/10	198319	2.208
SN 1735	Belt saw 1735x13x0.65mm P8/12	186682	2.194
SN 1735	Belt saw 1735x13x0.65mm P10/14	141865	12.366
SIENA 210	Belt saw 2110x20x0.90mm P8/12	353459	1047.13
SIENA 210	Belt saw 2110x20x0.90mm P6/10	353442	1047.12
SIENA 210	Belt saw 2110x20x0.90mm P10/14	353466	1047.14
SIENA 270	Belt saw 2450x27x0.90mm P4/6	789524	40.106
SIENA 270	Belt saw 2450x27x0.90mm P6/10	340565	40.73
SIENA 270	Belt saw 2450x27x0.90mm P8/12	340558	40.74
SIENA 270	Belt saw 2450x27x0.90mm P10/14	340541	40.75
SIENA 320	Belt saw 2680x27x0.90mm P4/6	356726	1047.26
SIENA 320	Belt saw 2680x27x0.90mm P6/10	345782	1047.3
SIENA 320	Belt saw 2680x27x0.90mm P8/12	741850	1047.4
SIENA 320	Belt saw 2680x27x0.90mm P10/14	753952	1047.5
SIENA 370	Belt saw 3160x27x0.90mm P4/6	353510	1047.19
SIENA 370	Belt saw 3160x27x0.90mm P6/10	355033	1047.25
SIENA 370	Belt saw 3160x27x0.90mm P8/12	353527	1047.20

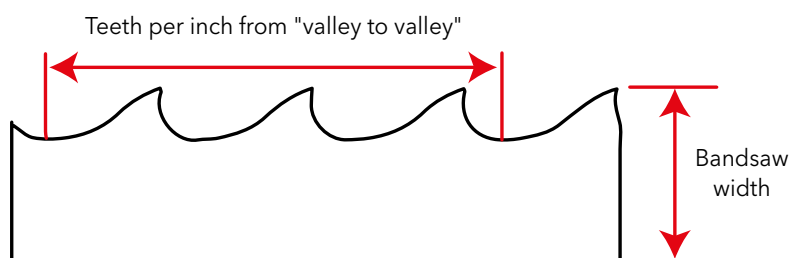

Die router bits



6 die router bits set with 6mm shaft.
Wood routing, made of carbon steel and high performance double width.
High wear resistance for a long lifespan.
Suitable for all kinds of wood.
Designed for evening, routing and kitchen assembly.
8 mm insertion, Check availability

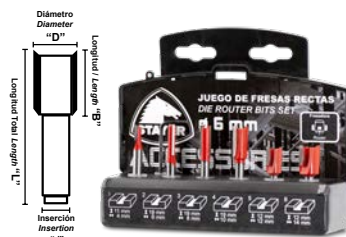

2 hollow bits of 12 & 14mm, reinforced.

Faster routing
More material removal



Icon	N°	Insertion "d" (mm)	Diameter "D" (mm)	Length "B" (mm)	Lt "L" (mm)	Code
	1	6	4	11	51	1.2462
	2	6	6	19	51	
	3	6	8	19	51	
	4	6	10	19	51	
	5	6	12 hollow	12	38	
	6	6	14 hollow	12	38	

N°	Insertion "d" (mm)	Diameter "D" (mm)	Length "B" (mm)	Lt "L" (mm)	Code
1	8	4	11	51	1.2620
2	8	6	19	51	
3	8	8	19	51	
4	8	10	19	51	
5	8	12 hollow	12	38	
6	8	14 hollow	12	38	

10 die router bits set with 6mm shaft.

10 die router bits set with 6mm shaft.
Wood routing, made of carbon steel and high performance double width.
High wear resistance for a long lifespan.
Suitable for all kinds of wood.
Designed for evening, routing and kitchen assembly.

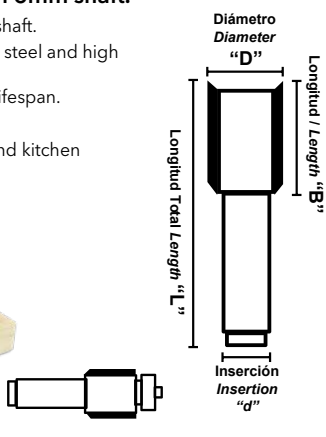

Icon	N°	Insertion "d" (mm)	Diameter "D" (mm)	Length "B" (mm)	Lt "L" (mm)	Code
	1	6	3	11	51	1.2366
	2	6	4	11	51	
	3	6	5	11	51	
	4	6	6	19	51	
	5	6	8	19	51	
	6	6	10	19	51	
	7	6	12	19	51	
	8	6	14	19	51	
	9	6	18	19	51	
	10	6	12.7	25.4	63	

12 mixed router bits set (die bits & shaped bits) for an optimal finish on hard wood, soft wood and wood compounds.

Different shapes for different bevel patterns.
Suitable for assemblers, carpenters and construction workers.
Suitable for any router with a 6mm insertion.
Long lifespan.
Carbon steel bit with high performance width.

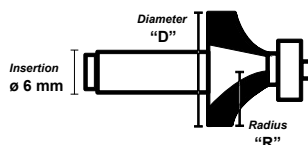

N°	Insertion "d" (mm)	Diameter "D" (mm)	Radius "R"	Code
1	6	12.7	6.35	1.351
2	6	22	6.35	
3	6	12.7	-	
4	6	32	-	
5	6	12.7	-	
6	6	16	-	
7	6	22	6.35	
8	6	12	-	
9	6	6	-	
10	6	28.6	9.5	
11	6	12.7	-	
12	6	25.4	4	

N°	Insertion "d" (mm)	Diameter "D" (mm)	Radius "R"	Code
1	8	12.7	6.35	1.2738
2	8	22	6.35	
3	8	12.7	-	
4	8	32	-	
5	8	12.7	-	
6	8	16	-	
7	8	22	6.35	
8	8	12	-	
9	8	6	-	
10	8	28.6	9.5	
11	8	12.7	-	
12	8	25.4	4	

Collet & Nuts for Routers



Tool	Contains	Width	Code
PR 10	Collet + nut	6 mm	12.491
PR 10	Collet + nut	6.3 mm	12.492
PR 10	Collet + nut	8 mm	12.493
PR 10	Collet + nut	10 mm	12.494
PR 10	Collet + nut	12 mm	12.495
PR 10	Collet + nut	12.7 mm	12.496
PR 6	Nut		5019.435
PR 6	Collet		5019.436

Planner blades



Set	Width	Code
2	82 mm	12.195
2	110 mm	12.605



	Diameter	Code
Disc TCT Z6	Ø 100x4x22mm	12.286



Set	Biscuit	Grain	Code
100	Wood	20	11.2493
100	Wood	10	11.2494
100	Wood	0	11.2495

- Carbide reversible blades for electric planer.
- Suitable for 82mm - 3 1/4" planers (cod. 12.195).
- Suitable for 110mm - 4 3/8" planers (cod. 12.605).
- Always use eye and hands protection. Follow your electric planer users manual instructions.
- Each blade has 2 cutting edges that may inverted. When both edges are blunt the blade must be replaced. This blades are not suitable for resharpening.
- To replace the tool blades plug it out from the power socket. Loosen the 2 screws holding the blade and slide the drum sideways.
- Always avoid touching the edges with your fingers.
- Once the screws have been loosened the blade may be stuck due to dust or work pressure. Use a wood chunk to hit the blade to unblock it.

Oscillating multi tool accessories

Immersion die saw HCS

- Immersion die saw HCS (**High Carbon Steel**) for oscillating multi tools.
- Flat open insertion, easy and quick tool coupling with no other tools needed.
- Compatible with most of the main brands.
- Specially designed for **Wood, plastic & drywall cutting**. For deep cuts, for reducing, opening holes and grounded cuts.
- Sizes 32 x 40 x 90 mm.

Code:
12.548



Semi circular saw HCS

- Semi circular saw HCS (**High Carbon Steel**) for oscillating multi tools.
- Flat open insertion, easy and quick tool coupling with no other tools needed.
- Compatible with most of the main brands.
- Specially designed for **Wood, plastic & drywall cutting**. Specially suited for hard to reach areas, grounded cuts, and edge cutting.
- Sizes 88 x 65 mm.

Code:
12.550



Immersion die saw BIM

- Immersion die saw BIM (**Bimetallic**) for oscillating multi tools.
- Flat open insertion, easy and quick tool coupling with no other tools needed.
- Compatible with most of the main brands.
- Specially designed for **metal, wood with nails, plastic and hard woods**. For deep cuts, for reducing, opening holes and grounded cuts.
- Sizes 32 x 40 x 90 mm.

Code:
12.549



Semi circular saw BIM

- Semi circular saw BIM (**Bimetallic**) for oscillating multi tools.
- Flat open insertion, easy and quick tool coupling with no other tools needed.
- Compatible with most of the main brands.
- Specially designed for **metal, wood with nails, plastic and hard woods**. Specially suited for hard to reach areas, grounded cuts, and edge cutting.
- Sizes 88 x 65 mm.

Code:
12.551



Diamond die saw

- Diamond die saw for oscillating multi tools.
- Flat open insertion, easy and quick tool coupling with no other tools needed.
- Compatible with most of the main brands.
- Specially designed for **tiles, ceramic materials & glass cutting**. For deep cuts, for reducing, opening holes and grounded cuts.
- Sizes 20 x 32 x 85 mm.

Code:
12.553



Semi circular diamond saw

- Diamond edge semi circular saw for oscillating multi tools.
- Flat open insertion, easy and quick tool coupling with no other tools needed.
- Compatible with most of the main brands.
- Specially designed for **tiles, ceramic materials & glass cutting**. Specially suited for hard to reach areas, grounded cuts, and edge cutting.
- Sizes 88 x 65 mm.

Code:
12.554





Oscillating multi tool accessories

Self adhering delta plate

- Self adhering plate for oscillating multi tools.
- Flat open insertion, easy and quick tool coupling with no other tools needed.
- Compatible with most of the main brands.
- Specially designed to be used as a delta sanding sheet support to sand wood, plastics & metals. The delta shape allows hard to reach and edges sanding.
- **Sizes 93 x 93 x 93 mm**

Code:
12.557



Diamond delta plate

- Diamond delta plate for oscillating multi tools.
- Flat open insertion, easy and quick tool coupling with no other tools needed.
- Compatible with most of the main brands.
- **Specially designed for ceramic materials, masonry and hard adhesive materials sanding.**
- For edge sanding, plaster and mortar polishing. The delta shape allows hard to reach and edges sanding.
- **Sizes 78 x 78 x 78 mm**

Code:
12.555



Scraper

- Scratching scraper for oscillating multi tools.
- Flat open insertion, easy and quick tool coupling with no other tools needed.
- Compatible with most of the main brands.
- Specially designed to scratch, tear off and strip. Remove silicon, glue, old paint or carpet.
- **Sizes 52 x 50 x 95 mm**

Code:
12.552



Set de Sanding sheets Delta autoadherentes

- Specially designed to be attached to a delta plate to sand woods & plastics.
- Delta shape allows for corners and edge sanding.
- Compatible with MULTITOOL PRO300, MULTI L20 & MULTI L18 from STAYER
- **Sizes 93 x 93 x 93 mm**

Model	Pcs	Grain	Code
Multi Tool	10	40x2 - 60x3 80x3 - 120x2	12.556
	5	60	12.814
	5	80	12.815
	5	120	12.816
	5	180	12.817

Code:
12.556



Oscillating multi tool accessories

Tiling set (4 Pcs)

- 4 Accessories set for oscillating multi tools specially suited for tiling.
- Flat open insertion, easy and quick tool coupling with no other tools needed.
- Compatible with most of the main brands.
- **Scraper** (52 x 49 x 99 mm): Specially designed to scratch, tear off and strip. Remover silicon, glue, old paint or carpet.
- **Diamond delta plate** (73 x 73 mm): Specially designed for ceramic materials, masonry and hard adhesive materials sanding.
- For edge sanding, plaster and mortar polishing. The delta shape allows hard to reach and edges sanding.
- **Diamond die saw** (20 x 32 x 85 mm): Specially designed for **tiles, ceramic materials & glass cutting**. For deep



Code:
12.558

- cuts, for reducing, opening holes and grounded cuts.
- **Diamond edge semi circular saw** (88 x 55 mm): Specially designed for **tiles, ceramic materials & glass cutting**. Specially suited for hard to reach areas, grounded cuts, and edge cutting.

Wood & Drywall (4 Pcs)

- 4 Accessories set for oscillating multi tools specially suited for wood and drywall.
- Flat open insertion, easy and quick tool coupling with no other tools needed.
- Compatible with most of the main brands.
- **Scraper** (52 x 49 x 99 mm): Specially designed to scratch, tear off and strip. Remover silicon, glue, old paint or carpet.
- **Immersion die saw BIM** (32 x 40 x 90 mm): Specially designed for **metal, wood with nails, plastic and hard woods**. For deep cuts, for reducing, opening holes and grounded cuts.
- **Immersion die saw HCS** (32 x 40 x 90 mm): Specially designed for **wood, plastic & drywall cutting**. For deep cuts, for reducing, opening holes and grounded cuts.
- **Semi circular saw HCS** (88 x 65 mm): Specially designed for **Wood, plastic & drywall cutting**. Specially suited for hard to reach areas, grounded cuts, and edge cutting.



Code:
12.559



Multidrill accessories

Roughing & Cutting



Rotary precision drill accessories set.
 180 Pcs for all kinds of jobs, cutting, polishing, sanding, brightening, etc...on any kind of surface and material.
 Easy and quick accessory exchange.
 Ø 3.10mm shaft.

180 Pcs set		Code
x 10	Sanding rolls (Grain)	1.891
x 1	Felt plate 25.4x3.2 mm	
x 1	Felt roll	
x 4	Felt wheel	
x 1	Felt wheel 9.5x19 mm	
x 2	Sanding roll shafts	
x 4	Diamond bits	
x 1	HSS cylyndrical drill bit	
x 3	Aluminum oxide wheel with shank	
x 6	Aluminum oxide grindstone	
x 2	Silicon carbide grindstone with shank	
x 6	Silicon carbide grindstone	
x 2	Nylon brushes	
x 3	Stainless steel brushes	
x 1	Brass brush	
x 1	Waxing / polishing compound	
x 30	Cutting discs 24x0.8 mm	
x 46	Cutting discs 24x0.4 mm	
x 45	Sanding discs	
x 3	Chromed shafts (3.2 / 2.4 / 1.6)	
x 1	Cutting disc shaft	
x 1	Flap wheel shaft	
x 1	Felt wheel shaft	
x 2	Fibreglass abrasive cutting discs	
x 1	Key 9.5 mm	
x 1	Flap wheel with shaft 32x9.5 mm	
x 1	Silicon carbide cated sharpening stone	

Multidrill Accessories

Sanding & Roughing Code:1.2330



Rotary precision drill accessories set.
40 Pcs for sanding & roughing on different materials (wood, metal, etc...)
Perfect finish on multiple surfaces.
Small size case for an easy and comfortable storage and transportation.
Ø 3.10mm shaft diameter

40 pcs set

x 4	Cutting discs	Ø 3.2 mm
x 10	Sanding rolls	12.7 mm
x 1	Sanding shaft	Ø 3.2 mm
x 1	Roll shaft	Ø 3.17 mm
x 4	Abrasive points	20x3.2 mm
x 20	Sanding discs	

Cutting Code:1.2328



Rotary precision drill accessories set.
Specially assembled for cutting different types of materials. (wood, metal & construction materials).
Small size case for an easy and comfortable storage and transportation.
89 Pcs set.
Ø3.10mm shaft diameter

89 Pcs set

x 1	Diamond disc	22x0.6 mm
x 1	Saw blade	22x0.3 mm
x 18	Fibreglass disc	32x1.2 mm
x 2	Cutting disc	32x1.6 mm
x 36	Cutting disc	24x0.6 mm
x 30	Cutting disc	24x0.8 mm
x 1	2 pieces shaft	Ø 3.17 mm

Cutting & Roughing Code:1.2327



Rotary precision drill accessories set.
Specially assembled for cutting and roughing different types of materials.
Its wide array of components makes this set suitable for all types of surfaces with a great finish.
Ø3.10mm shaft

102 Pcs set

x 3	Aluminum oxide points
x 3	Silicon carbide points
x 6	Nickel & rubber points
x 3	Roughing discs
x 3	Sanding discs
x 6	Rubber sanding discs
x 40	Sanding sheets 20 mm
x 36	Cutting discs 24 mm
x 2	Shaft

Polishing Code:1.2329



Rotary precision drill accessories set.
Specially designed for cleaning and polishing any kind of material.
Includes polishing compound for a perfect finish.
Quick tool change with great precision on any area of work.
Ø 3.10mm shaft.

20 pcs set

x 4	Brush	Ø3.2 mm
x 3	Felt disc	25x6.3 mm
x 6	Felt disc	12.7x6.3 mm
x 2	Rubber support	22x3 mm
x 1	Polishing wheel	
x 1	Felt polishing wheel	
x 1	Polishing compound	
x 1	Sanding discs shaft	Ø 3.17 mm
x 1	Felt discs shaft	Ø 3.17 mm



SILICON CARBIDE ROLL

- 100 x 100 x 19 mm roller for metal cleaning, removal of rust and paint as well as burrs. Especially suitable for preparing metals for welding, anodizing or zinc plating.

- Large sanding surface, specially designed for demanding work on large surfaces, leaving a clean and uniform finish.

- Compatible with M8 insert sanding machines. - Manufactured with a nylon fiber structure reinforced with silicon carbide (SiC), the main advantage of these discs lies in their flexibility, generating less temperature when applied on materials.



Dimensions	Code
------------	------

100 x 100 x 19	12.862
----------------	--------

BRASS WIRE ROLL

- 100 x 100 x 19 mm roller for wood graining, rust removal and metal polishing.

- Large sanding surface, specially designed for demanding jobs on large surfaces, leaving a clean and uniform finish.

- Brass plated steel wires, with medium hardness and high polishing and graining capacity. Brass ensures that the brush does not spark and gives a smoother and more polished finish than steel.

- Compatible with M8 insert polishers.



Dimensions	Code
------------	------

100 x 100 x 19	12.863
----------------	--------

NYLON ROLL

- 100 x 100 x 19 mm roller for wood structuring and texturing, rust removal and grain highlighting.

- Large sanding surface, specially designed for demanding jobs on large surfaces, leaving a clean and uniform finish.

- Nylon filaments with coarse aluminum oxide abrasive grit. The filaments are flexible, allowing access to all types of angles in irregular pieces, without scratching the surface or altering the dimensions of the piece.

- Compatible with M8 insert polishers.



Dimensions	Code
------------	------

100 x 100 x 19	12.864
----------------	--------

ABRASIVE AND LAMINATED ROLL

- Efficient material removal.

- Provides uniform finish.

- Fits any 19mm shaft diameter glazing machine.

- Long roller life.

- Sand and polish at the same time.

- For polishing / sanding on flat surfaces.

Whether metallic, such as stainless steel, brass, copper etc... and on wood and plastics.



Size	Dimensions	Code
------	------------	------

ABRASIVE ROLL

Fine	105x100x19	8180.150
------	------------	----------

Thick	105x100x19	8180.151
-------	------------	----------

LAMINATED ROLL

Fine	105x100x19	8180.152
------	------------	----------

Thick	105x100x19	8180.153
-------	------------	----------

BRASS WIRE BRUSH

For grinder.l. Ø 150mm, shaft 150x20.

Code:
12.57



WIRE CUP BRUSH

Brush with medium abrasive grade, specially indicated for polishing and finishing operations. It presents an excellent performance in deburring, removing rust and paint.

The brass wires are more flexible, which facilitates the access to narrow or difficult to reach areas.

Code:
12.865



TWISTED WIRE BRUSH

- Twisted wire brush in cup (12.866): brush with coarse abrasive grade, especially suitable for deburring operations on large surfaces. It has a high starting capacity and excellent performance at high revolutions.

- Flat twisted wire brush (12.867): brush with coarse abrasive grade, especially suitable for deburring and cleaning operations on welds and forgings. Optimal for retreading and glass recovery.

Ø (mm)	Code
--------	------

65	12.50
----	-------

100	12.55
-----	-------



Vacuum cleaner accessories

VAC 2030

Accessory	Code
Cloth filter	8190.102
Washable filter bag	8190.103



Cloth filter



Washable filter bag

VAC 2050 C

Accessory	Code
Cloth filter	8190.97
HEPA Filter	8190.49
Vacuum tube	8190.99
Flat nozzle	8190.92
Vacuum brush	8190.94
Circular brush	8190.93
Vacuum tube	8190.91
Flexible hose	8190.95



Cloth filter



HEPA Filter



Vacuum hose



Flat nozzle



2 positions brush



Circular brush



Flexible hose 1.5m Ø40mm
Flexible hose 4m Ø40mm



Metallic vacuum tube

BVAC 2000

Accessory	Code
HEPA Filter	8276.527
Floor brush (liquids)	8276.552
Floor brush (solids)	8276.554
Flexible hose	8276.553
Vacuum tube	8276.556
Flat nozzle	8276.557
Circular brush	8276.558
Upholstery nozzle	8276.559
Auxiliary air input filter	8276.539
Auxiliary air output filter	8276.546



HEPA Filter



Floor brush (liquids)



Floor brush (solids)



Flexible hose



Vacuum tube



Flat nozzle



Upholstery nozzle

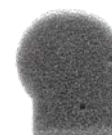

Auxiliary air input filter
Auxiliary air output filter



Vacuum cleaner accessories

BVAC 2200 E

Accessory	Code
Liquids filter	8130.123
Solids filter	8130.58
Floor brush (liquids)	8130.124
Floor brush (solids)	8130.108
Flat nozzle	8130.102
Small washable bag	8130.122
Big washable bag	8130.125
Adaptor	75.281
Nozzle	8130.103
Telescopic tube	8130.104



Liquids filter



Floor brush (liquids)



Solids filter



Floor brush (solids)



Small washable bag



Big washable bag



Flat nozzle



Adaptor



Nozzle

BVAC 2400 DM

Accessory	Code
HEPA Filter	12.714
Floor brush (liquids)	12.715
Floor brush (solids)	12.716
Flexible hose	12.713
Vacuum tube	12.712
Flat nozzle	12.718
Circular brush	12.717



HEPA Filter



Floor brush (liquids)



Floor brush (solids)



Flexible hose



Vacuum tube



Flat nozzle



Circular brush

High pressure water cleaner accessories

HL 105 B / HL 135

Accessory	Code
Gun	8276.412
Turbo lance	8276.564
Fan lance	8276.414
Conector	8276.413

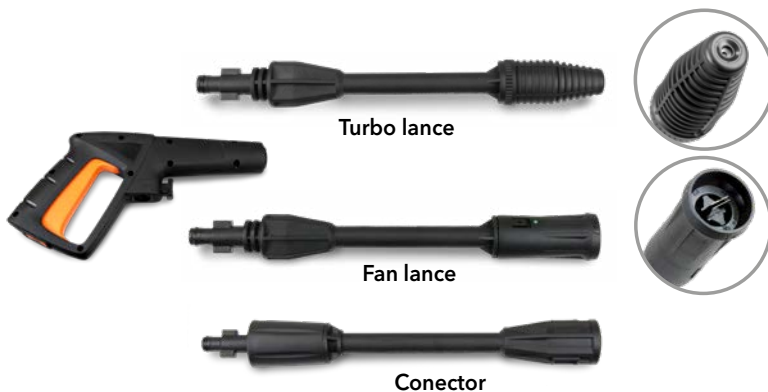

HL 2000 / HL 2200

Accessory	Code
Gun	8276.114
Turbo lance	8276.106
Fan lance	8276.263



HLC 2000

Accessory	Code
Gun	8276.488
Conector	8276.487
Turbo nozzle	8276.490
45° nozzle	8276.491
Fan nozzle	8276.492

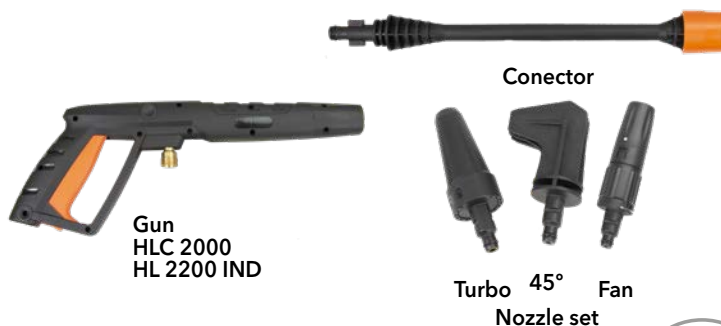

HL 2200 IND

Accessory	Code
Gun	8276.488
Turbo lance	8276.106
Fan lance	8276.263



HL 105 B / HL 2000 / HLC 2000 / HL 2200 IND / HL 135 / HL 2200

Accessory	Code
Brush	8276.326
Floor brush 200mm	8276.325
Flushing pipe 6m	8276.324
Rotary brush	8276.323
Foam tank	8276.651





High pressure water cleaner accessories

HL 2700 IND / HL 2700 B IND

Accessory	Code
Gun	8276.53
Turbo lance	8276.565
Fan lance	8276.566

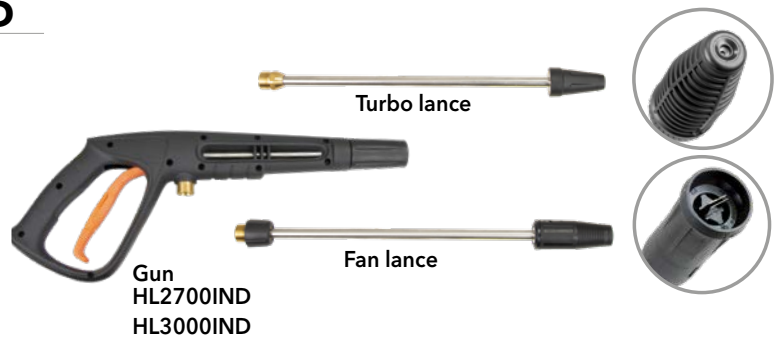

HL 3000 IND

Accessory	Code
Gun	8276.53
Intermediate lance	8276.567
Nozzle 0°	8276.88
Nozzle 15°	8276.90
Nozzle 25°	8276.89
Nozzle 40°	8276.91
Nozzle Soap	8276.562
Nozzle turbo	8276.93



HL 2700 IND / HL 3000 IND / HL 2700 B IND

Accessory	Code
Rotary brush	8276.426
Floor brush 200mm	8276.652
Flushing pipe + Adaptor	8276.654
Adaptor	8276.653
Extensor hose 5m	8276.571
Brush adaptor	8276.563
Foam tank	8276.650



COMMON ACCESSORIES

Accessory	Code	R.S.P.
Water filter	8276.343	3.15€
HPC conector	8276.327	5.00€





WELDING



INDEX

MMA



OVERCONTROL 166
MINIPRO 100

CITYWORK 167

Citywork 1250 GE K
Citywork 160 GE K
Citywork 160 GE KI

SUPER PLUS 168

Super plus 120 GE K
Super plus 140 GE K
Super plus 160 GE K
Super plus 200 GE K 169

POTENZA 170

Potenza 200 GE K
Potenza 200 CEL GE K
Potenza 160 B

PROGRESS 171

Progress 1200 GEK 171
Progress 1600 GEK
Progress 2021 GEK 172
Progress 200 Pulsed GE 173
Gama PFC 174
Progress 1700 PFC 175
Progress 2100 PFC

INDUSTRIAL 176

S 250 DV
S 400 T

110 V 177

Citywork 140 LV GE K
Citywork 180 DV GE K
Potenza 200 GEK Bitensión

TIG



TIG HF 179

Potenza TIG 170 HF GEK
Potenza TIG 170 HF GEK 2T/4T
TIG DC 200 HF B P

TIG AC/DC 180

TIG AC/DC 180
TIG AC/DC 350 HF

MIG - MAG



MIG - MAG 181

MIG 131 Multi 182
MIG 165 Multi
MIG 200 Multi 183
MIG 250 CM
MIG 250 CT
MIG 350 BT 184
MIG 500 BT
MIG 200 Double pulsed 185
MIG 280 Double pulsed 186
MIG350 Double pulsed

PLASMA



PLASMA 188

Plasma 40 COM GE
Plasma Multi 40 GE
Plasma 100 T GE

MASKS 189

GS - 0B
ANSI 2000
AS - 1D
AS - R
AS - RT 190
CARNIVAL 1
CARNIVAL 3
AS - X
AS - XL

Accessories 191

Electrodes
Spools Of Thread
Tungsten Electrodes
Masks
Cables And Pieces
Other Accessories
Plasma Torches
Mig Consumables
Mig Guns
Tig Torches
Tig Consumables

Welding MMA

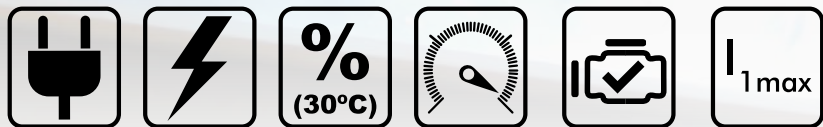

Model	Code	Input 50 / 60 Hz Phases	Voltage (V)	Duty Cycle STAYER 30°C (%)	Maximum current (A)	Generator Recommended (KVA) AVR*	Maximum input consumption (A) I _{1max}
MINIPRO 100	1.2681	1	230	25	100	4	20.4
CITYWORK 1250 GEK	1.2615	1	230	100	125	5	23.6
CITYWORK 160 GEK	1.2041	1	230	100	160	7	29
SUPERPLUS 120 GEK	1.2376	1	230	100	120	5	23.4
SUPERPLUS 140 GEK	1.2470	1	230	100	140	7	25.1
SUPERPLUS 160 GEK	1.2381	1	230	100	160	7	29
SUPERPLUS 200 GE	1.2382	1	230	45	200	8	39.2
POTENZA 160 B	1.2616	1	230	100	160	7	29
POTENZA 200 GE	2.287	1	230	60	200	8	33
POTENZA 200 CEL GE	2.302	1	230	60	200	8	33
PROGRESS 1200 GEK	1.2455	1	230	100	125	5	23.4
PROGRESS 1200 PFC	1.2455	1	230	100	125	3.6	23.4
PROGRESS 1600 GEK	1.2570	1	230	100	160	7	29
PROGRESS 1600 PFC	1.2570	1	230	100	160	5.8	29
PROGRESS 2021 GEK	1.2668	1	230	100	200	8	39.2
PROGRESS 2021 PFC	1.2668	1	230	100	200	7.1	39.2
PROGRESS 200 PULSED	1.2403	1	230	100	200	8	37
PROGRESS 1700 PFC	1.1542	1	110 / 230	100	170	5.8	35 / 22
PROGRESS 2100 PFC	1.1363	1	110 / 230	100	210	7.2	44 / 28.2
S 250 DV	1.1749	1	230/400	60	200 / 250	10	47 / 33
S 400 T	1.1750	3	400	60	400	20	29
CITYWORK 140 LV	1.2259	1	110	100	140	7	43
CITYWORK 180 DV	1.2260	1	110 / 230	100 / 60	120 / 180	7	35.5 / 30.5
POTENZA 200 BIVoltage	2.318	1	110 / 230	100 / 60	160 / 210	7	58 / 38

* Recommended values using Generators AVR (Automatic Voltage Regulator).

Minimum values recommended obtained using the welding equipment at minimum performance in a controlled environment under specific conditions.

For an optimum tool usage we advise using an AVR generator capable of providing maximum intake KVA for the tool.





Ru

Bas

Cel

Al



 TIG



POWER FACTOR
PFC
 CORRECTOR

 SINÉRGICO

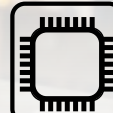
VOLTAGE
 REDUCTION
VRD
 DEVICE



Rutile	Basic	Cellulosic	Aluminum	TIG Lift Arc	Máx Ø Electrode	PFC	Synergic	VRD	Micro-processor STAYER
✓	X	X	X	X	2.5	X	X	X	X
✓	✓	X	X	X	3.2	X	X	X	✓
✓	✓	X	X	X	4.0	X	X	X	✓
✓	✓	X	X	X	3.2	X	X	X	✓
✓	✓	X	X	X	4.0	X	X	X	✓
✓	✓	X	X	X	4.0	X	X	X	✓
✓	✓	X	X	X	5.0	X	X	X	✓
✓	✓	X	X	X	4.0	X	X	X	✓
✓	✓	X	X	✓	5.0	X	X	X	✓
✓	✓	✓	X	✓	5.0	X	X	X	✓
✓	✓	X	X	X	3.2	X	X	X	✓
✓	✓	X	X	X	3.2	X	X	X	✓
✓	✓	✓	X	✓	4.0	X	✓	✓	✓
✓	✓	✓	X	✓	4.0	X	✓	✓	✓
✓	✓	✓	✓	✓	5.0	X	✓	✓	✓
✓	✓	✓	✓	✓	5.0	X	✓	✓	✓
✓	✓	✓	✓	✓	5.0	✓	X	✓	✓
✓	✓	✓	✓	✓	5.0	X	✓	✓	✓
✓	✓	✓	✓	✓	6.0	✓	X	✓	✓
✓	✓	✓	✓	✓	6.0	X	X	X	X
✓	✓	✓	✓	✓	8.0	X	X	X	X
✓	✓	X	X	X	4.0	X	X	X	✓
✓	✓	X	X	X	5.0	X	X	X	✓
✓	✓	X	X	✓	5.0	X	X	X	✓

PROTECTION INVERTER

OVERCONTROL V2

Cod. 1.1494

Rated Voltage	230 50Hz - 400 Hz	V
Rated Amperage	16A RSM over Rated Voltage	A
Max. Amperage	40A RSM over Rated Voltage	A
Adjustable Protection	LO140-240V / HI240V-400V	V
Fixed Protection	<300V, 50Hz - 400Hz	V
Power intake	50	W
Efficiency	99,98	%
Protection	IP20	
Display Precision	±4	%
Size	11.3 x 12 x 14	cm
Power cable	2.1m / 3 x 25 mm ²	
Weight	1.6	kg



- **2 POLES:** Total disconnection, phase and neutral
- **LIMITS:** Adjustable limits UP & DOWNS
- **NO RELAYS:** No mechanical contact

VOLTAGE PROTECTION FOR Welding equipments

The vast majority of welding equipment on the market has a thin +/-10% protection margin of voltage rises and downs. The majority of standard welding equipment has a low protection against peaks and voltage transients.

INVERTER with OVERCONTROL

1. Against peaks of voltage rise and falls due to the overcontrol interposition between power and the equipment.
2. The equipment is disconnected until its power input is safe again, after a 2-second security period for stability.

INVERTER MMA 100A

MINIPRO 100

Cod. 1.2681

Output Power	100	A
Voltage	230	V
Duty Cycle	25	%
Electrodes	1.6 - 2.5	mm
Generator use	4 KVA / 230V ±17%	
Size	25 x 18 x 11	cm
Weight	2.5	kg
DINSE Connector	1/2" (35 - 50)	ø
Power cable	1.2	m
Cable + Earth clamp	1.5m - 12 mm ²	
Cable + Electrode clamp	1.5m - 12 mm ²	
Hammer / Brush		✓



Small & lightweight inverter welding equipment for coated electrodes, able to reach up to 100 Amperes.

- For coated electrodes up to **ø2,5mm**.
- Optimal performance with **Rutile electrodes**.
- Robust: metal structure, heat protection



GAMA CITYWORK - INVERTER MMA

CITYWORK 1250 GEK

Cod. 1.2615

CITYWORK 160 B GEK

Cod. 1.3234

CITYWORK 1600 GEKI

Cod. 1.2676

**HIGH PERFORMANCE EQUIPMENT WITH
REDUCED DIMENSIONS**



	CITYWORK 1250 GEK	CITYWORK 160 B GEK	CITYWORK 1600 GEKI
Output Power	125 A	160 A	160 A
Voltage	230 V	230 V	230 V
Duty Cycle (30°C)	100 %	100 %	100 %
Electrodes	1.6 - 3.2 mm	1.6 - 4 mm	1.6-4 mm
Generator use	5 KVA / 230V ±17%	7 KVA / 230V ±17%	9 KVA / 230V ±17%
Size	23 x 15.5 x 9 cm	25 x 15 x 10 cm	25x15x9 cm
Weight	2.5 kg	2.7 kg	2.7 kg
DINSE Connector	3/8" (10 - 25) ø	3/8" (10 - 25) ø	3/8" (10 - 25) ø
Power cable	2m x 1.5 mm ²	1.8m x 1.5 mm ²	2m x 1.5 mm ²
Cable + Earth clamp	1.5m - 10 mm ²	1.5m - 16 mm ²	1.5m - 16 mm ²
Cable + Electrode clamp	2.5m - 10 mm ²	2.5m - 16 mm ²	2.5m - 16 mm ²
Hammer / Brush	✓	✓	✓
Carry Case	✓	✓	✓
Mask	✓	X	X

Inverter equipments 100% Duty Cycle at 30°C, Reduced dimensions & high performance.

- Microprocessor STM 32 F103 with 32 bits high speed response, real time operative system due to the exclusive STAYER software.
- Suitable for the following electrodes: **Rutile, Basic, inox, & cast.**
- Easy to use, with Hot Start (easy arc ignition), arc force (arc stabilization) & anti stick (prevents electrodes from sticking).
- Ready for Stabilized generators use, with a voltage input deviation of +/-17%.
- Designed and produced under european regulations 2014/35/UE, 2014/30/EU & 2011/65/EU which warrant a safe and solid design.



SUPER PLUS LINE - INVERTER MMA

SUPER PLUS 120 GEK

Cod. 1.2376

SUPER PLUS 140 GEK

Cod. 1.2470

SUPER PLUS 160 GEK

Cod. 1.2381

HIGH PERFORMANCE EQUIPMENT WITH REDUCED DIMENSIONS



	SUPER PLUS 120 GEK	SUPER PLUS 140 GEK	SUPER PLUS 160 GEK
Output Power	120 A	140 A	160 A
Voltage	230 V	230 V	230 V
Duty Cycle (30°C)	100 %	100 %	100 %
Electrodes	1.6 - 3.2 mm	1.6 - 4 mm	1.6 - 4 mm
Generator use	5 KVA / 230V ±17%	7 KVA / 230V ±17%	7 KVA / 230V ±17%
Size	23 x 15.5 x 9 cm	24 x 15.5 x 9 cm	25 x 15.5 x 9 cm
Weight	2.5 kg	3 kg	3.3 kg
DINSE Connector	3/8" (10 - 25) ø	3/8" (10 - 25) ø	3/8" (10 - 25) ø
Power cable	2m x 1.5 mm ²	2m x 1.5 mm ²	2m x 2.5 mm ²
Cable + Earth clamp	1.5m - 10 mm ²	1.5m - 10 mm ²	1.5m - 16 mm ²
Cable + Electrode clamp	2.5m - 10 mm ²	2.5m - 10 mm ²	2.5m - 16 mm ²
Hammer / Brush	✓	✓	✓
Carry Case	✓	✓	✓

STAYER most sold inverter welding equipment. Professional duty cycle with reduced size. Latest generation microprocessor updated in 2021, providing stability & and precision for coated electrode welding.

- High quality components, reinforced ventilation, & exclusive STAYER software for best performance.
- Last generation IGBTs, oversized condensers & enhanced heat dissipation to reach maximum performance with reduced dimensions.
- Compact & tough design, reinforced structure protected against hits.
- Suitable for the following electrodes: **Rutile, Basic, inox & cast.**
- Easy to use, with Hot Start (easy arc ignition), arc force (arc stabilization) & anti stick (prevents electrodes from sticking).
- Ready for Stabilized generators use, with a voltage input deviation of +/-17%.
- Designed and produced under european regulations 2014/35/UE, 2014/30/EU & 2011/65/EU which warrant a safe and solid design.



SUPER PLUS LINE - INVERTER MMA - 200A

SUPER PLUS 200 GE K

Cod. 1.2382

HIGH PERFORMANCE EQUIPMENT

Output Power	200	A
Voltage	230	V
Duty Cycle (30°C)	45	%
Electrodes	1.6 - 5	mm
Generator use	9 KVA / 230V ±17%	
Size	30 x 20 x 13	cm
Weight	4.8	kg
DINSE Connector	1/2" (35 - 50)	∅
Power cable	2m x 2.5 mm ²	
Cable + Earth clamp	1.5m - 25 mm ²	
Cable + Electrode clamp	2.5m - 25 mm ²	
Hammer / Brush		✓



STAYER most sold inverter welding equipment. Professional duty cycle with reduced size. Latest generation microprocessor, providing stability & and precision for coated electrode welding.

- High quality components, reinforced ventilation, & exclusive STAYER software for best performance.
- Last generation IGBTs, oversized condensers & enhanced heat dissipation to reach maximum performance with reduced dimensions.
- Compact & tough design, reinforced structure protected against hits.
- Suitable for the following electrodes: **Rutile, Basic, inox & cast.**
- Easy to use, with Hot Start (easy arc ignition), arc force (arc stabilization) & anti stick (prevents electrodes from sticking).
- Ready for Stabilized generators use, with a voltage input deviation of +/-17%.
- Designed and produced under european regulations 2014/35/UE, 2014/30/EU & 2011/65/EU which warrant a safe and solid design.



POTENZA LINE - INVERTER MMA - 160A

POTENZA 160 B GEK

Cod. 1.2616

Output Power	160	A
Voltage	230	V
Duty Cycle (30°C)	100	%
Electrodes	1.6 - 4	mm
Generator use	7 KVA / 230V ±17%	
Size	28.5 x 20 x 12.5	cm
Weight	2.4	kg
DINSE Connector	3/8" (10 - 25)	ø
Power cable	2m x 2.5 mm ²	
Cable + Earth clamp	1.5m - 16 mm ²	
Cable + Electrode clamp	2.5m - 16 mm ²	
Hammer / Brush		✓
Carry Case		✓



ROBUST & HIGH PERFORMANCE EQUIPMENT WITH STANDARD DIMENSIONS

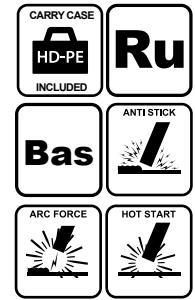

160 Amperes welding equipment with reinforced structure, for coated electrodes.

- 100% duty cycle at 30°C.
- Protected against temperature and voltage variations.
- Suitable for 4mm electrodes.
- Microprocessor 32 bits, including STAYER intelligent control software.
- Compact & **robust**, reinforced structure protected against hits with external protectors.
- Easy to use, with Hot Start (**easy arc ignition**), arc force (for a **stable arc**) & anti stick (to avoid stuck electrodes).
- Ready for Stabilized generators use, with a voltage input deviation of +/-17%.
- Designed and produced under european regulations 2014/35/UE, 2014/30/EU & 2011/65/EU which warrant a safe and solid design.

POTENZA LINE - INVERTER MMA

POTENZA 200 GE

Cod. 2.287

POTENZA 200 GEK

Cod. 2.316

POTENZA 200 CEL GEK

Cod. 2.302



ROBUST & HIGH-PERFORMANCE EQUIPMENT WITH STANDARD DIMENSIONS & CLASSIC CONTROLS

POTENZA 200 GE

POTENZA 200 CEL GEK

	POTENZA 200 GE	POTENZA 200 CEL GEK
Output Power	200	200
Voltage	230	230
Duty Cycle (30°C)	60	60
Electrodes	1.6 - 5	1.6 - 5
Generator use	9 KVA / 230V ±17%	9 KVA / 230V ±17%
Size	42 x 30 x 14	42 x 30 x 14
Weight	6	6
DINSE Connector	1/2" (35 - 50)	1/2" (35 - 50)
Power cable	2m x 2.5 mm ²	2m x 2.5 mm ²
Cable + Earth clamp	2m x 25 mm ²	2m x 25 mm ²
Cable + Electrode clamp	3m x 25 mm ²	3m x 25 mm ²
Hammer / Brush		✓
Carry Case		✓

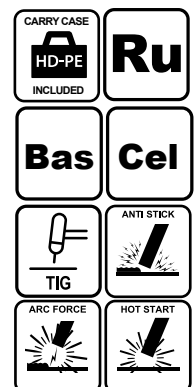

200 Amperes high performance Inverter equipments, with quality components that guarantee maximum robustness & welding precision.

- 60% duty cycle.
- Protected against temperature and voltage variations.
- Suitable for 5mm electrodes. Suitable for the following electrodes: **Rutile, Basic, Cellulosic, inox, high performance & cast.**
- Microprocessor 32 bits, including STAYER intelligent control software.
- Great response times due to last generation IGBTs & updated software.
- DINSE 1/2" connectors for maximum power output
- Easy to use, with Hot Start (**easy arc ignition**), arc force (for a **stable arc**) & anti stick (to avoid stuck electrodes).
- Ready for Stabilized generators use, with a voltage input deviation of +/-17%.
- **Potenza 200 CEL GE**, has an outstanding performance with **Cellulosic electrodes**. Including TIG Lift Arc.

PROGRESS LINE - INVERTER MMA -125A

PROGRESS 1200 GEK

Cod. 1.2719

PROGRESS 1200 GEK

Output Power	120	A
Voltage	230	V
Duty Cycle (30°C)	100	%
Electrodes	1.6 - 3.2	mm
Generator use	5 KVA / 230V ±17%	
Size	20 x 12 x 9	cm
Weight	2	kg
DINSE Connector	3/8" (10 - 25)	∅
Power cable	1.8m x 1.5 mm ²	
Cable + Earth clamp	1.5m - 10 mm ²	
Cable + Electrode clamp	2.5m - 10 mm ²	
Hammer / Brush		✓
Carry Case		✓

**HIGH PERFORMANCE EQUIPMENT
WITH REDUCED DIMENSIONS**



125 Amperes compact welding equipment, small size with 100% Duty Cycle.

- Microprocessor STM 32 F103 **32 bits** with high speed, real time operative system due to exclusive STAYER software.
- Protected against temperature and voltage variations
- Suitable for 3,2mm electrodes: **Rutile, Basic, inox, cast & high performance.**
- Easy to use, with Hot Start (easy arc ignition), arc force (for a stable arc) & anti stick (to avoid stuck electrodes).
- Ready for Stabilized generators use, with a voltage input deviation of +/-17%.
- Designed and produced under european regulations 2014/35/UE, 2014/30/EU & 2011/65/EU which warrant a safe and solid design.



PROGRESS LINE - INVERTER MMA -160A

PROGRESS 1600 GEK

Cod. 1.2570

PROGRESS 1600 GEK

Output Power	160	A
Voltage	230	V
Duty Cycle (30°C)	100	%
Electrodes	1.6 - 4.0	mm
Generator use	7 KVA / 230V ±17%	
Size	31 x 17.5 x 10	cm
Weight	3.2	kg
DINSE Connector	3/8" (10 - 25)	∅
Power cable	2.5m x 2.5 mm ²	
Cable + Earth clamp	1.5m - 16 mm ²	
Cable + Electrode clamp	2.5m - 16 mm ²	
Hammer / Brush		✓
Carry Case		✓

**OPTIMAL PERFORMANCE WITH DIFFERENT
ELECTRODES TYPES
DIAMETER AND ARC FORCE SETTINGS**



Superior welding equipment with 160 Amperes, with synergic electronic settings for all kind of electrodes & configurable for TIG Lift Arc with no contact.

- **Synergic settings** for electrodes up to 4mm.
- Last generation IGBTs, enhanced silent heat dissipation to reach maximum performance.
- Adjustable **VRD**, Voltage Reduction Device to maintain safety on the group connectors according to IEC 60974, reducing voltage in damp and saline environments.
- Incremental **Arc Force** regulation for all types of coated electrodes.
- Control panel managed by STAYER software, with synergic amp regulation based on electrode diameter, configurable **Arc Force**, **VRD** for safe welding & **TIG Lift Arc** mode.
- Easy to use, with Hot Start (easy arc ignition) & anti stick (to avoid stuck electrodes) coded with STAYER software.
- Designed and produced under european regulations 2014/35/UE, 2014/30/EU & 2011/65/EU which warrant a safe and solid design
- Ready for Stabilized generators use, with a voltage input deviation of +/-17%.



PROGRESS LINE - INVERTER MMA -200A

PROGRESS 2021 GEK

Cod. 1.2668

Output Power	200	A
Voltage	230	V
Duty Cycle (30°C)	60	%
Electrodes	1.6 - 5.0	mm
Generator use	7 - 9 KVA / 230V ±17%	
Size	34.5 x 24 x 14	cm
Weight	5	kg
DINSE Connector	1/2" (35 - 50)	ø
Power cable	2m x 2.5 mm ²	
Cable + Earth clamp	1.5m - 25 mm ²	
Cable + Electrode clamp	2.5m - 25 mm ²	
Hammer / Brush		✓
Carry Case		✓



OPTIMAL PERFORMANCE WITH ALL TYPES OF ELECTRODES
SPECIALLY DESIGNED FOR ALUMINUM & CELLULOSIC DIFFICULT WELDING
ELECTRODE DIAMETER & ARC FORCE REGULATION

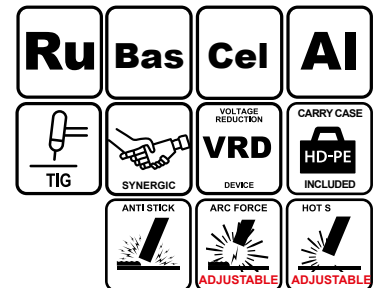

200 Amperes superior welding equipment, with electronic synergic settings for all kind of electrodes, specially aluminum & TIG Lift Arc with intelligent settings.

- **Synergic configuration** based on electrode diameter up to 5mm. **Suitable for all kind of electrodes.**
- Last generation components, max quality IGBTs & internal enhanced design with improved silent cooling.
- **4 diode bridges**, for greater stability and power.
- Control panel managed by STAYER software, with synergic amp regulation based on electrode diameter, configurable Arc Force & Hot Start, VRD for safe welding & TIG Lift Arc mode.
- **Synergic TIG PRO** intelligent mode, connecting a TIG torch the group is set to **TIG Lift Arc** with clean quality arcing.
- Special for **Aluminum electrodes**.
- Adjustable VRD, Voltage Reduction Device to maintain safety on the group connectors according to IEC 60974, reducing voltage in damp and saline environments.
- Incremental Arc Force & Hot Start regulation for all types of coated electrodes.
- Intelligent Anti Stick programmed with STAYER software.
- Designed and produced under european regulations 2014/35/UE, 2014/30/EU & 2011/65/EU which warrant a safe and solid design
- Ready for Stabilized generators use, with a voltage input deviation of +/-17%.

PROGRESS LINE - INVERTER MMA -200A

PROGRESS 200 PULSED GE

Cod. 1.2403

Output Power	200	A
Voltage	230	V
Duty Cycle	100	%
Electrodes	1.6 - 5.0	mm
Generator use	7 - 9 KVA / 230V ±17%	
Size	40 x 27.5 x 15.5	cm
Weight	6	kg
DINSE Connector	1/2" (35 - 50)	∅
Power cable	3m x 3.0	mm ²
Cable + Earth clamp	2m - 25	mm ²
Cable + Electrode clamp	3m - 25	mm ²
Hammer / Brush		✓

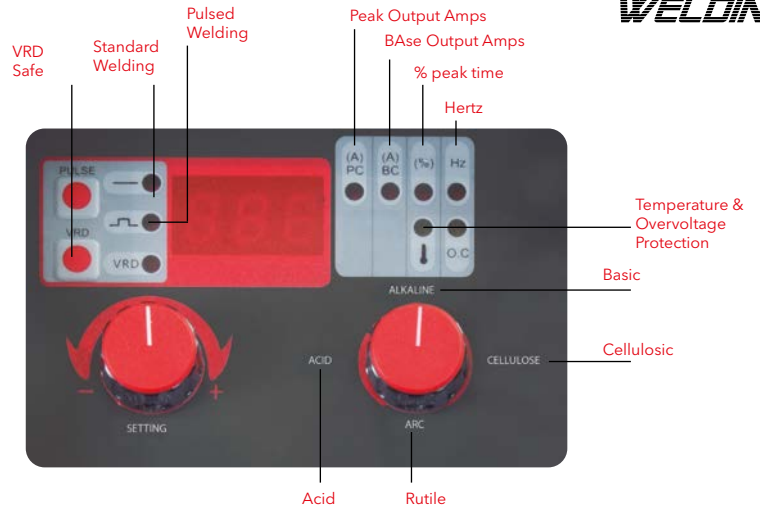

OPTIMAL PERFORMANCE ON THIN SHEETS AND VERTICAL POSITION
REPROGRAMMABLE FOR ALL ELECTRODE TYPES

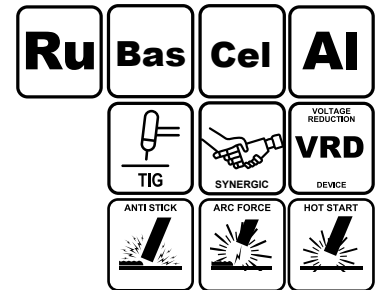
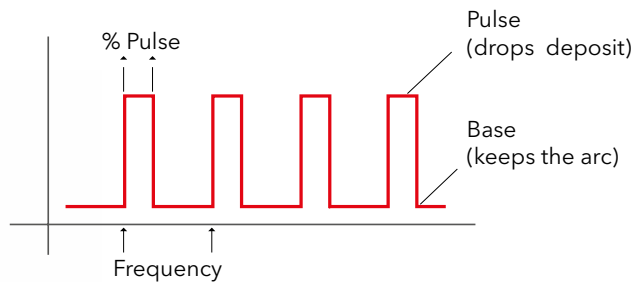

Superior welding equipment with 200 Amperes, special for thin welding & different welding positions due to the pulsed mode.

- Use with all kind of electrodes, including aluminum.
- Suitable for any kind of maintenance, construction and steel structures fields work.
- Professional advanced settings with **2 Features**:
 - **Pulsed welding**: Allows thin thickness in requested positions such as vertically, above heads and tubes (all ASME 3G, 4G and 5G). This is possible to the pulsed arc system where a base-current is used to keep the arc stability. Also, a peak current for metal droplets deposition. Depending on each work, the base, current peak, percentage of time of every phase and the operating frequency are adjusted.
 - **Electrode settings** grants the best performance on **Rutile, Basic, Cellulosic, aluminum, inox, cast, high performance, etc.**
- **Synergic TIG PRO** intelligent mode, connecting a TIG torch the group is set to TIG Lift Arc with clean quality arcing.
- Easy to use, with Hot Start (easy arc ignition), arc force (arc stabilization) & anti stick (prevents electrodes from sticking).
- Reinforced internal structure for a robust group
- Microprocessor 32 bits, Oversized ON-OFF switch 63 A; fast IGBTs with heat dissipation, **Soft Start relay**.
- Adjustable VRD, Voltage Reduction Device to maintain safety on the group connectors according to IEC 60974, reducing voltage in damp and saline environments.
- Designed and produced under european regulations 2014/35/UE, 2014/30/EU & 2011/65/EU which warrant a safe and solid design
- Ready for Stabilized generators use, with a voltage input deviation of +/-17%.

PROGRESS PFC RANGE

PFC: POWER FACTOR CONTROL

The STAYER active pfc

Improves performance and saves money on electricity bills and money savings on electricity bills and breakdowns.

Real case: Study of annual energy savings in a 170-210 amp equipment (inverter equipment).

*Data from the Ministry of Industry year 2022 - 2006 / 42 / EC.

IN COMPARISON	SAVES OVER INVERTER USE
INDUSTRIAL USE	680 euros/year
MAINTENANCE USE	204 euros/year

Electricity price = 0.227 €/kWh*
 Industrial use average = 4h/day - 5 days a week
 Maintenance use average = 1,5h/day - 4 days a week

MULTI-VOLTAGE 85 - 265 V.
 Energy saving up to 50%.
 Allows long cables: 300m.
 Allows smaller generators.

KEY CONCEPTS ABOUT STAYER'S ACTIVE PFC

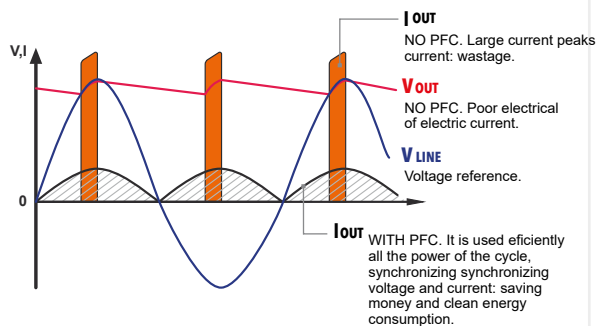

SINGLE-VOLTAGE 230V COSφ < 0.65

WITHOUT PFC

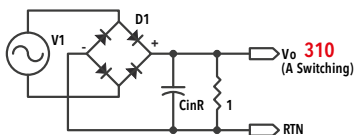

MULTIVOLTAGE 85V-265V COSφ > 0.99

WITH PFC STAYER

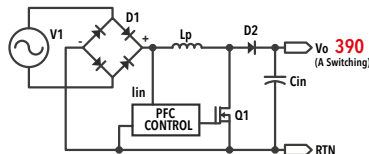

FEATURES

- Multi-voltage inverter equipment (85-265Vac) with low power consumption thanks to the PFC module and advanced technology.
- PFC, Power Factor Correction for optimal use of current, greatly increasing electrical savings.
- Wide input range to be able to work in 110V and 230V networks, in addition to withstand voltage drops and surges, being suitable for use with generator.
- Connectable to long extension cables: 250mts - 4mm² section / 500mts - 6,0mm² section.

ADVANTAGES

WITH STAYER ACTIVE PFC

- Big money saving: 99% efficiency compared to 70-80% of other inverters.
- Uses any power supply: the machine works safely in overvoltage and undervoltage conditions, it works perfectly from 85 to 265 volts. Extended input voltage range.
- Environmentally friendly: the power supply line is kept clean of harmonics and related problems under the UNE-EN 61000-3-12:2012 standard.
- Adaptable and productive: the machine remains 100% safe, even with low quality generators and 500 meter long cables.
- Customer service quality: it can weld safely with 4mm electrodes with a consumption lower than 16 amperes, preventing the safety circuit breakers from tripping.

PROGRESS LINE PFC - INVERTER MMA - 100%

PROGRESS 1700 PFC (85 V - 265 V)

Cod. 1.1542

PROGRESS 2100 PFC (85 V - 265 V)

Cod. 1.1363

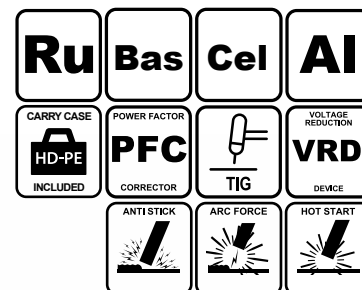

	PROGRESS 1700 PFC		PROGRESS 2100 PFC	
Output Power	170	A	210	A
Voltage	85 - 265	V	85 - 265	V
Duty Cycle	100	%	100	%
Electrodes	1.6 - 5	mm	1.6 - 6	mm
Generator use	5.8 KVA / 230V ±27%		7.2 KVA / 230V ±27%	
Size	38 x 24 x 13	cm	41 x 24 x 14.5	cm
Weight	6.4	kg	8.4	kg
DINSE Connector	1/2" (35 - 50)	∅	1/2" (35 - 50)	∅
Power cable	3m x 2.5 mm ²		3m x 3.0 mm ²	
Cable + Earth clamp	2m x 25 mm ²		2m x 25 mm ²	
Cable + Electrode clamp	2m x 25 mm ²		2m x 25 mm ²	
Hammer / Brush		✓		✓

Inverter equipments multi voltage (85-265Vac) with low consumption due to PFC & advanced technology.

- **PFC, Power Factor Corrector** for an optimal use of the output power, drastically reducing electric consumption.
- High quality & efficient welding with all **types of Electrodes, included aluminum.**
- Great input range allows to work in **110V & 230V environments**, resisting over voltage & voltage drops, with an excellent performance with generators.
- Suitable for great length extension cables: 250mts - 4mm² / 500mts - 6,0mm².
- Settings for enhanced use with generator with the control panel.
- Adjustable VRD, Voltage Reduction Device to maintain safety on the group connectors according to IEC 60974, reducing voltage in damp and saline environments.
- **TIG** welding mode, for **TIG Lift Arc** with quality clean arcing.
- Automatic fan regulator, avoiding noise while increasing the group lifespan

MULTI-VOLTAGE 85 - 265 V
Energy savings up to 50%.
Allows long cables: 300m.
Allows smaller generators.

INTELLIGENT SPEED CONTROL FAN

Silent and economical: Exclusive Smart fan system to save electricity costs, extend the life of the fan, prevent the entry of dirt and have a silent and comfortable welding. The fan only rotates when the machine needs it and at the minimum speed necessary.



INVERTER MMA DUAL - SINGLE & TRIPHASIC -250A/200A

S 250 DV

Cod. 1.1749

Output Power	250 / 200	A
Voltage	400 / 230	V
Duty Cycle	60	%
Electrodes	1.6 - 6	mm
Generator use	5 - 10 KVA / 230V ±17%	
Size	48 x 39 x 23	cm
Weight	18	kg
DINSE Connector	1/2" (35 - 50)	ø
Power cable	2m x 4 mm ²	
Cable + Earth clamp	2m - 25 mm ²	
Cable + Electrode clamp	2m - 25 mm ²	

Industrial welding equipment for 230Vac & 400Vac. Suitable for every type of electrode with an outstanding welding performance.

- Up to **6mm electrodes, all kinds, including aluminum & Cellulosic.**
- Excellent **TIG, TIG Lift Arc** with quality clean arcing.
- Easy to use, with **Hot Start** (easy arc ignition), arc force (arc stabilization) & anti stick (prevents electrodes from sticking).
- Designed and produced under european regulations 2014/35/UE, 2014/30/EU & 2011/65/EU which warrant a safe and solid design
- Ready for Stabilized generators use, with a voltage input deviation of +/-17%.

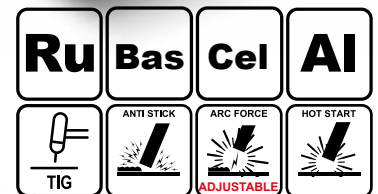

INVERTER MMA TRIPHASIC -400A

S 400 T

Cod. 1.1750

Output Power	400	A
Voltage	3 ph 400	V
Duty Cycle	60	%
Electrodes	1.6 - 8	mm
Generator use	8 - 20 KVA / 230V ±17%	
Size	48 x 37 x 23	cm
Weight	20	kg
DINSE Connector	1/2 (35 - 50)"	ø
Power cable	2m x 4 mm ²	
Cable + Earth clamp	5m - 35 mm ²	
Cable + Electrode clamp	5m - 35 mm ²	

Industrial welding equipment for high demand & heavy duty enviroments.

Suitable for every type of electrode with an outstanding welding performance

- Up to **8mm electrodes, all kinds, including aluminum & Cellulosic.**
- Professional settings for **Arc Force** as well as **Hot Start**.
- Easy to use, with **Hot Start** (easy arc ignition), arc force (arc stabilization) & anti stick (prevents electrodes from sticking).
- High quality: Double structure 100% metal for heavy duty work, wheels, and components made of steel.
- Designed and produced under european regulations 2014/35/UE, 2014/30/EU & 2011/65/EU which warrant a safe and solid design
- Ready for Stabilized generators use, with a voltage input deviation of +/-17%.



INVERTER MMA - 110V & DUAL VOLTAGE

CITYWORK 140 LV GEK

Cod. 1.2259

CITYWORK 180 DV GEK

Cod. 1.2260

POTENZA 200 BIVoltage

Cod. 2.318



	CITYWORK 140 LV GEK	CITYWORK 180 DV GEK (BITENSION)	POTENZA BITENSION 200 GEK
Output Power	140 A	120 / 180 A	160 / 210 A
Voltage	110 V	110 / 230 V	110 / 230 V
Duty Cycle	100 %	100 / 60 %	100 / 60 %
Electrodes	1.6 - 4.0 mm	3.2 - 5 mm	1.6 - 5.0 mm
Generator use	5 - 7 KVA / 230V ±17%	5 - 7 KVA / 230V ±17%	5 - 7 KVA / 230V ±17%
Size	26 x 15 x 11 cm	27 x 15 x 11 cm	42 x 30 x 14 cm
Weight	2 kg	2.7 kg	5 kg
DINSE Connector	3/8" (10 - 25) ø	3/8" (10 - 25) ø	1/2" (35 - 50) ø
Power cable	1.8m x 3 mm ²	1.8m x 3 mm ²	3m x 2.5 mm ²
Cable + Earth clamp	1.5m - 14 mm ²	1.5m - 16 mm ²	2m - 25 mm ²
Cable + Electrode clamp	2.5m - 14 mm ²	1.5m - 16 mm ²	2m - 25 mm ²
Hammer / Brush	✓	✓	✓
Carry Case	✓	✓	✓

Inverter equipments designed for 110V or alternate between 110V & 230V.

- Easy to use, with Hot Start (easy arc ignition), arc force (arc stabilization) & anti stick (prevents electrodes from sticking).
- Ready for Stabilized generators use, with a voltage input deviation of +/-17%.
- **CITYWORK:** Inverter equipments **100% Duty Cycle at 30°C, Reduced dimensions & high performance.** Microprocessor STM 32 F103 with 32 bits with high speed, real time operative system due to exclusive STAYER software.
- **POTENZA:** Suitable for both **110V** and **230V** with automatic voltage change. With **TIG lift arc** feature.
- Designed and produced under european regulations 2014/35/UE, 2014/30/EU & 2011/65/EU which warrant a safe and solid design.

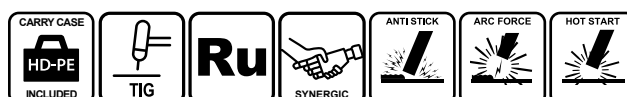

WELDING TIG

Model	POTENZA TIG 170 HF GEK	POTENZA TIG 170 HF GEK 2T / 4T	TIG DC 200 HFB P	TIG AC/DC 180 HF PS	TIG AC/DC 315 HF PS
Code	2.317	2.827	1.2886	1.2887	1.1366
Input 50 / 60 Hz Phases	1	1	1	1	3
Voltage (V)	230	230	230	230	400
Duty Cycle STAYER 30°C (%)	60	60	60	60	60
Max. Current (A)	170	170	200	200	315
Max. intake (KVA)	7	7	9	9	12
Recommended Generator (AVR)*	7	7	9	9	12
Max. intake Input (A) $I_{L_{1max}}$	29.5	29.5	33	33	17
Polaridad	DC	DC	DC	AC/DC	AC/DC
Aluminum	X	X	X	✓	✓
Coated Electrodes (MMA)	✓	✓	✓	✓	✓
TIG HF (High Frequency no contact)	✓	✓	✓	✓	✓
TIG Pulsed	X	X	✓	✓	✓
Max Ø Electrode Tugstsen	3.25	3.25	3.25	3.25	4
Water cooling	X	X	X	X	✓
2T / 4T	X	✓	✓	✓	✓



* Recommended values using Generators AVR (Automatic Voltage Regulator).

Minimum values recommended obtained using the welding equipment at minimum performance in a controlled environment under specific conditions.

INVERTER TIG HF -170A

POTENZA TIG 170 HF GEK

Cod. 2.317

POTENZA TIG 170 HF GEK 2T/4T

Cod. 2.827

Output Power	170	170	A
Voltage	230	230	V
Duty Cycle	60	60	%
Coated electrodes	1.6 - 4	1.6 - 4	mm
Tungsten electrodes	3.25	3.25	mm
Generator use	7 KVA / 230V ±17%	7 KVA / 230V ±17%	
Size	46 x 27 x 14.5	46 x 27 x 14.5	cm
Weight	5	5	kg
DINSE Connector	1/2" (35 - 50)	1/2" (35 - 50)	ø
Power cable	2m x 2.5 mm ²	2m x 2.5 mm ²	
Cable + Earth clamp	2m - 25 mm ²	2m - 25 mm ²	
Cable + Electrode clamp	3m - 25 mm ²	3m - 25 mm ²	
TIG Torch HF	4	4	m
Torch accessories	✓	✓	
Carry Case	✓	✓	

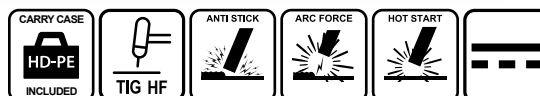

TIG welding equipment, for heavy duty carbon steel, stainless steel, titanium & alloy welding. Suitable for coated electrodes up to 170 Amperes.

- Highly productive **TIG**, high frequency arcing HF.
- Control Power & Argon post flow.
- Reinforced robust metal structure.
- Coated electrodes up to **4mm**
- Easy to use, with Hot Start (easy arc ignition), arc force (arc stabilization) & anti stick (prevents electrodes from sticking).
- Ready for Stabilized generators use, with a voltage input deviation of +/-17%.

INVERTER TIG HF -200A

TIG DC 200 HF B P

Cod. 1.2886

Output Power	200	A
Voltage	230	V
Duty Cycle	60	%
Coated electrodes	1.6 - 6	mm
Tungsten electrodes	3.25	mm
Generator use	9 KVA / 230V ±17%	
Size	-	cm
Weight	11	kg
DINSE Connector	1/2" (35 - 50)	ø
Power cable	2m x 2.5 mm ²	
Cable + Ground clamp	2m x 25 mm ²	
Cable + Electrode clamp	2m x 25 mm ²	
TIG Torch HF	4m x 16 mm ²	
Torch accessories	✓	
Gas hose	✓	

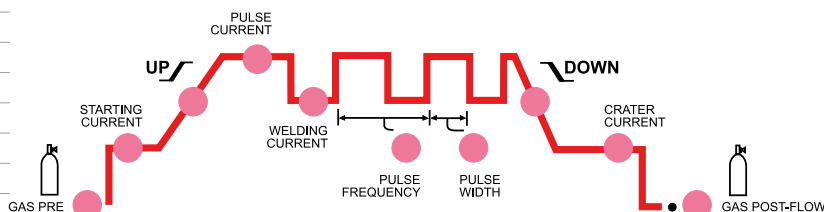
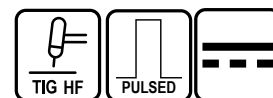

TIG welding equipment, for heavy duty carbon steel, stainless steel, titanium & alloy welding. Suitable for coated electrodes up to 200 Amperes

- **Pulsed TIG welding** controlling the base output power, and active welding peaks. Duty cycle control & Argon post flow
- Highly productive **TIG**, high frequency arcing (HF).
- Reinforced robust metal structure
- Multi process TIG with High Frequency (HF), adjustable opening welding times, 2T/4T, TIG, Pulsed TIG & ramps control for all kind of materials, except for aluminum.
- Designed and produced under european regulations 2014/35/UE, 2014/30/EU & 2011/65/EU which warrant a safe and solid design
- Adjustable VRD, Voltage Reduction Device to maintain safety on the group connectors according to IEC 60974, reducing voltage in damp and saline environments.
- Ready for Stabilized generators use, with a voltage input deviation of +/-17%.



INVERTER TIG AC/DC PULSED - 200A

TIG AC/DC 180 HF PULSED

Cod. 1.2887

Output Power	200	A
Voltage	230	V
Duty Cycle	60	%
Coated electrodes	1.6 - 6	mm
Tungsten electrodes	3.25	mm
Generator use	9 KVA / 230V ±17%	
Size	-	cm
Weight	12	kg
DINSE Connector	1/2" (35 - 50)	∅
Power cable	2m x 2.5	mm ²
Cable + Earth clamp	2m - 25	mm ²
Cable + Electrode clamp	2m - 25	mm ²
TIG Torch HF	4m x 16	mm ²
Torch accessories		✓
Gas hose		✓



TIG welding equipment for professional use, 60% duty cycle up to 200 amperes, especially designed work on stainless steel, aluminum, alloys and all types of steels.

- Welding control options by means of intuitive panel managed by microprocessor with STAYER software.
- Professional HF-HV (High Frequency/High Voltage) 2T/4T priming functions, DC mode control, pulse mode control, AC mode control, ramp and gas control, gas flow and post flow control.
- Equipment designed and manufactured according to European regulations 2014/35/EU, 2014/30/EU and 2011/65/EU, which guarantee a solid construction and safety of use.
- Prepared for use with stabilized generator, given its voltage input range of +/-17%.

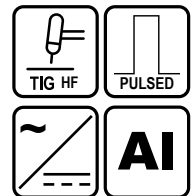

INVERTER TIG AC/DC PULSED - 315A

TIG AC/DC 315 HF P

Cod. 1.1366

Output Power	315	A
Voltage	3 PH x 400	V
Duty Cycle	60	%
Coated electrodes	1.6 - 6	mm
Tungsten electrodes	4	mm
Generator use	12 KVA / 230V ±17%	
Size	76 x 115 x 51.5	cm
Weight	71	kg
DINSE Connector	1/2" (35 - 50)	∅
Power cable	3m x 4	mm ²
Cable + Earth clamp	3m - 35	mm ²
Cable + Electrode clamp	3m - 35	mm ²
TIG Torch HF	5m x 16	mm ²
Torch accessories		✓



Professional TIG welding equipment, 60% duty cycle & 315 Amperes specially suited for inox, aluminum, alloys & all kind of steels. Water cooling, suitable for high temperature environments.

- Intuitive control panel managed by microprocessor with **software STAYER**.
- Professional settings of HF-HV (High Frequency / High Voltage) 2T/4T, optional DC control mode, pulse mode, AC control, ramp control & gas, flow & post flow. Spot welding with and without repetition.
- **Water cooling** for heavy duty heated environments & aluminum welding up to 315 Amperes.
- **Optional:** Connector to enable a pedal to control Amps on professional TIG welds.
- **Double reactor** to generate Alternate Current (AC) to weld **aluminum** with precision.
- Reinforced robust metal structure, quality components, last generation EMI filter and double ventilation system.
- Ready for Stabilized generators use, with a voltage input deviation of +/-17%.
- Designed and produced under european regulations 2014/35/UE, 2014/30/EU & 2011/65/EU which warrant a safe and solid design

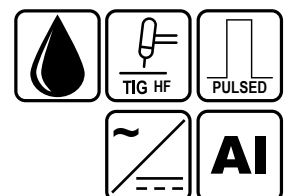

WELDING MIG



Model	Code	Input 50 / 60 Hz Phases	Voltage (V)	Duty Cycle STAYER 30°C (%)	Max. Current (A)	Max. intake (KVA)	Max. intake Input (A) I _{1max}	Wire Feeding (Rollers)
MIG 131 MULTI	1.2682	1	230	30	120	5	23,4	2R
MIG 165 MULTI	1.2688	1	230	60	160	7	24.9	2R
MIG 200 MULTI	1.739	1	230	60	200	9	48.2	2R
MIG 250 CM	1.2606	1	230	60	250	12	45	4R
MIG 250 CT	1.2683	3	400	60	250	12	14	4R
MIG 350 BT	1.1509	3	400	60	350	15	25.5	4R
MIG 500 BT	1.1510	3	400	60	500	25	41.8	4R
MIG 200 DP	1.2678	1	230	60	200	10	21.5	2R
MIG 280 DP	1.2401	3	400	60	280	14	15	4R
MIG 350 DP	1.2679	3	400	60	350	15	25.5	4R



Model	MIG/MAG (gas)	FLUX CORE (no gas)	Coils (Kg)	Wire Thickness	Coated Electrode (MMA)	TIG Lift Arc	Synergic	Double Pulse	Water Cooling
MIG 131 MULTI	X	✓	1	0.9 1.0	3.2	✓	✓	X	X
MIG 165 MULTI	✓	✓	5	0.6 - 0.9 1.0 Flux	4.0	✓	✓	X	X
MIG 200 MULTI	✓	✓	15	0.8 - 1.0	5.0	✓	X	X	X
MIG 250 CM	✓	✓	15	0.6 - 1.0	6.0	✓	✓	X	X
MIG 250 CT	✓	✓	15	0.8 - 1.0	6.0	✓	✓	X	X
MIG 350 BT	✓	✓	15	0.8 - 1.2	8.0	✓	✓	X	X
MIG 500 BT	✓	✓	15	0.8 - 1.6	8.0	✓	✓	X	✓
MIG 200 DP	✓	✓	15	0.8 - 1.2	5.0	✓	✓	✓	X
MIG 280 DP	✓	Adaptable a Flux Core	15	0.8 - 1.6	6.0	✓	✓	✓	X
MIG 350 DP	✓	✓	15	0.8 - 1.6	8.0	✓	✓	✓	X

* Recommended values using Generators AVR (Automatic Voltage Regulator).

Minimum values recommended obtained using the welding equipment at minimum performance in a controlled environment under specific conditions.

For an optimum tool usage we advise using an AVR generator capable of providing maximum intake KVA for the tool.

FLUX CORE MIG - 120A

MIG 131 MULTI

Cod. 1.2682

Output Power	120	A
Voltage	230	V
Duty Cycle	30	%
Coated electrodes	1.6 - 3.2	mm
Wire thickness	0.9 - 1.0	mm
Coil weight	0.5 - 1	kg
Generator use	5 KVA / 230V ±17%	
Size	33 x 13 x 25	cm
Weight	4.9	kg
DINSE Connector	3.8" (10 - 25)	ø
Power cable	2 x 1.5	mm ²
Cable + Earth clamp	1.5m - 10	mm ²
Cable + Electrode clamp	2.5m - 10	mm ²
Wire torch		✓

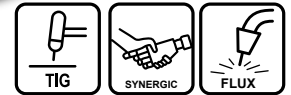

Welding equipment with Fundent Center Arc Welding FCAW (flux core, with built-in Torch). STAYER MIG MULTI LINE, suitable for coated electrodes.

- Lightweight & multi use equipment for **wire welding** with built-in torch for **coils up to 1 kg** with **no gas required**.
- Easy configuration & with welding modes for **0,9mm & 1mm flux core & coated electrode**, with a single button.
- Professional, **synergic settings** for **wire speed & output power** with fast response times, synchronizing both values.
- Easy set up without gas tanks required thanks to the **Flux Core**, flexible and versatile tool.
- Compact design, with carry handle & reduced weight, suitable for domestic use with 16A power intake limit.
- IGBT technology based on a last generation microprocessor able to use up to 120 Amperes.
- Ready for Stabilized generators use, with a voltage input deviation of +/-17%.
- Designed and produced under european regulations 2014/35/UE, 2014/30/EU & 2011/65/EU which warrant a safe and solid design

MIG MULTI RANGE / MIG - MAG

MIG 165 MULTI

Cod. 1.2688

Output Power	160	A
Voltage	230	V
Duty Cycle	60	%
Coated electrodes	1.6 - 4.0	mm
Wire thickness	0.6 - 1.0	mm
Coil weight	0.5 - 1 - 5	kg
Generator use	7 KVA / 230V ±17%	
Size	42 x 31 x 18	cm
Weight	13	kg
DINSE Connector	3/8" (10 - 25)	ø
Power cable	2m x 2.5	mm ²
Cable + Earth clamp	1.5m - 16	mm ²
Cable + Electrode clamp	2.5m - 16	mm ²
MIG Torch	15 AK	
Included contact tips	1.0	
Included rollers	0.8 - 1.0	



STAYER MIG MULTI Line, with EUROTORCH connection & Power at 160 Amperes.

- Designed for high quality MIG, TIG & MMA welding.
- Easy **MIG settings**, easy configuration for **flux core welding**.
 - With gas, connect the torch to the positive pole (+).
 - With flux core, connect the torch to the negative pole (-).
- Efficient and simple wire settings with 2 buttons: one for speed & other for voltage. A commutator enables different work modes **wire (MIG) & Electrode (MMA) & TIG**.
- Protected against high temperatures & over voltage.
- Completely equipped with torches, roller, earth and electrode clamps
- IGBT technology based on a last generation microprocessor able to use up to 160 Amperes.
- Portable & robust: Compact, low weight due to inverter circuits. Quality oversized components.
- For coils from **0.5 to 5Kg**.
- Ready for Stabilized generators use, with a voltage input deviation of +/-17%.
- Designed and produced under european regulations 2014/35/UE, 2014/30/EU & 2011/65/EU which warrant a safe and solid design

MIG MULTI RANGE / MIG - MAG 200A

MIG 200 MULTI

Cod. 1.739

Output Power	200	A
Voltage	230	V
Duty Cycle	60	%
Coated electrodes	1.6 - 5.0	mm
Wire thickness	0.8 - 1.0	mm
Coil weight	5 - 15	kg
Generator use	7 - 9 KVA / 230V ±17%	
Size	51 x 42 x 32	cm
Weight	22	kg
DINSE Connector	1/2" (35 - 50)	∅
Power cable	3.5m x 2.5 mm ²	
Cable + Earth clamp	3m - 25 mm ²	
Cable + Electrode clamp	3m - 25 mm ²	
MIG Torch	15 AK	
Contact tips	0.8	mm
Rollers	0.8 - 1.0	mm

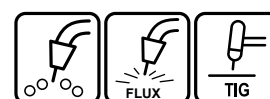

STAYER MIG MULTI Line, EUROTORCH connection 200 Amperes 60% duty cycle.

- Designed for high quality MIG, TIG & MMA welding.
- Easy **MIG settings**, easy configuration for **flux core welding**.
 - With gas, connect the torch to the positive pole (+).
 - With flux core, connect the torch to the negative pole (-).
- Efficient and simple wire settings with 2 buttons: speed & voltage. A commutator enables different working modes **wire (MIG) & Electrode (MMA) & TIG**.
- Protected against high temperatures & over voltages.
- Completely equipped with torches, roller, earth and electrode clamps
- IGBT technology based on the latest generation microprocessor able to work up to 200 A.
- Portable & robust: Compact, includes wheels for are easy handling. Quality oversized components.
- Ready for Stabilized generators use, with a voltage input deviation of +/-17%.
- Designed and produced under european regulations 2014/35/UE, 2014/30/EU & 2011/65/EU which warrant a safe and solid design

MIG - MAG SYNERGIC / 250A

MIG 250 CM (SINGLE PHASE)

Cod. 1.2601

MIG 250 CT (TRIPHASIC)

Cod. 1.2683

Output Power	250	A
Voltage	230 / 400	V
Duty Cycle	60	%
Coated electrodes	1.6 - 6.0	mm
Wire thickness	0.6 - 0.8 - 1.0	mm
Coil weight	5 - 15	kg
Generator use	12 KVA / 230V ±17%	
Size	89 x 69 x 32.5	cm
Weight	42	kg
DINSE Connector	1/2" (35 - 50)	∅
Power cable	2m x 2.5 mm ²	
Cable + Earth clamp	3m - 25 mm ²	
Cable + Electrode clamp	3m - 25 mm ²	
MIG Torch	25 AK	
Gas hose	3	m
Rollers	x2 / 0.8 - 1.0	mm

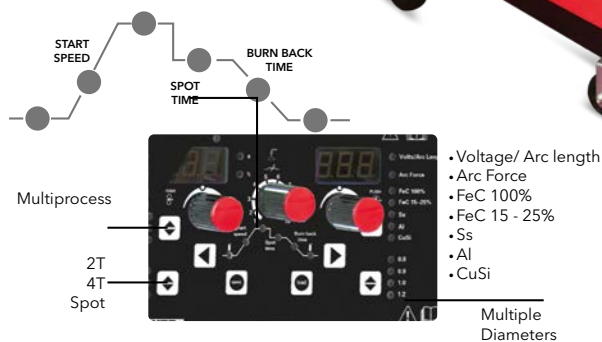

Synergic MIG-MAG, MMA & Spot welding equipment.

- Easy polarity inversion for **flux core welding**.
- Two displays for Output Power & Voltage with real time values. Included Spool gun connection.
- Designed and produced under european regulations 2014/35/UE, 2014/30/EU & 2011/65/EU.
- Ready for stabilized AVR 3x400V generators use, with a voltage input deviation of +/-17%.
- **Professional wire feeder**, with motor 60W, safe and stable wire reduction, suitable for **15 Kg coils**. Included **rollers for 0.6mm, 0.8mm & 1mm**.

MIG - MAG SYNERGIC 350A / 500A

MIG 350 BT

Cod. 1.1509

MIG 500 BT

Cod. 1.1510



Output Power	350 A	500 A
Voltage	3 x 400 V	3 x 400 V
Duty Cycle	60 %	60 %
Coated electrodes	1.6 - 8.0 mm	1.6 - 8.0 mm
Wire thickness	0.6 - 0.8 - 1.0 - 1.2 mm	0.8 - 1.0 - 1.2 - 1.6 mm
Coil weight	5 - 15 kg	5 - 15 kg
Generator use	15 KVA / 230V ±17%	25 KVA / 230V ±17%
Size	90 x 114 x 30 cm	100 x 160 x 33 cm
Weight	45 kg	50 kg
DINSE Connector	1/2" (35 - 50) ø	1/2" (35 - 50) ø
Power cable	3m x 4 mm ²	3m x 6 mm ²
Cable + Earth clamp	3m - 40 mm ²	3m - 40 mm ²
Cable + Electrode clamp	3m - 40 mm ²	3m - 40 mm ²
MIG Torch	36AK - 4m	501D - 4m
Pressure gauge	✓	✓ m
Rollers	(x2 0.8-1.0)(x2 1.0-1.2) mm	(x2 0.8-1.0)(x2 1.0-1.2) (x2 1.2-1.6) mm

Industrial Inverter welding equipments for non stop wire welding, MMA & MIG with detachable wire feeder

- Easy to use with simple control panels with manual/classical/synergic modes.
- Adjustable Arc Force for coated Cellulosic electrodes & improved TIG.
- Easy polarity inversion for flux core welding.
- Two displays for Output Power & Voltage with real time values. Included Spool gun connection.
- Designed and produced under european regulations 2014/35/UE, 2014/30/EU & 2011/65/EU.
- Ready for stabilized AVR 3x400V generators use, with a voltage input deviation of +/-17%.
- Detachable wire feeder can be placed 10 meters away from the group.
- Professional wire feeder, with motor 85W & 4 rolls push / pull, safe and stable wire reduction, suitable for 15 Kg coils.
- Intelligent Voltage, Output Power & Speed controlled from the wire feeder.



MIG - MAG SYNERGIC DOUBLE PULSE / 200A

MIG 200 DOUBLE PULSE

Cod. 1.2678

Output Power	200	A
Voltage	230	V
Duty Cycle	60	%
Coated electrodes	1.5 - 5.0	mm
Wire thickness	0.8 - 1.0 - 1.2	mm
Coil weight	5 - 15	kg
Generator use	10 KVA / 230V ±17%	
Size	58 x 40 x 27	cm
Weight	17.5	kg
DINSE Connector	1/2" (35 - 50)	∅
Power cable	3m - 2.5	mm ²
Cable + Earth clamp	2m - 25	mm ²
Cable + Electrode clamp	2m - 25	mm ²
MIG Torch steel	MB24 - 4m	
MIG Torch Aluminum	MB24 - 2m	
Rollers V	x2 (0.8 / 1.0)	mm
Rollers U	x4 (1.0 / 1.2)	mm



Industrial Inverter single-phase welding equipment for non stop wire welding, MMA & MIG, Intelligent synergic settings & great digital display 60% duty cycle.

- Great LCD screen with intuitive controls, to completely control and adjust the welding parameters.
- Built in microprocessor MCU for a fast and easy welding setting & control.
- Synergic system suitable for all kind of carbon steel & inox, magnesium / silicon aluminums & copper.
- Specific settings for coated electrodes MMA, pulse / double pulse & manual mode. Spray mode with no splatting on all kind of positions with pulse control.
- Memory to store welding settings.
- Sequence modes included: 2T, 4T, 4TH & Spot.
- Optimized settings for 0.8, 1.0 & 1.2mm wire.
- Includes two Torches 25mm². A short one special for aluminum & other for steels.
- Four contacts roller 'U' special for aluminum & 'V' special steel.
- Designed and produced under european regulations 2014/35/UE, 2014/30/EU & 2011/65/EU.
- Temperature & overcharge protection controlled by software.
- Ready for Stabilized generators use, with a voltage input deviation of +/-17%.



MIG - MAG SYNERGIC DOUBLE PULSE

MIG 280 DOUBLE PULSE

Cod. 1.2401

MIG 350 DOUBLE PULSE

Cod. 1.2679

NEW

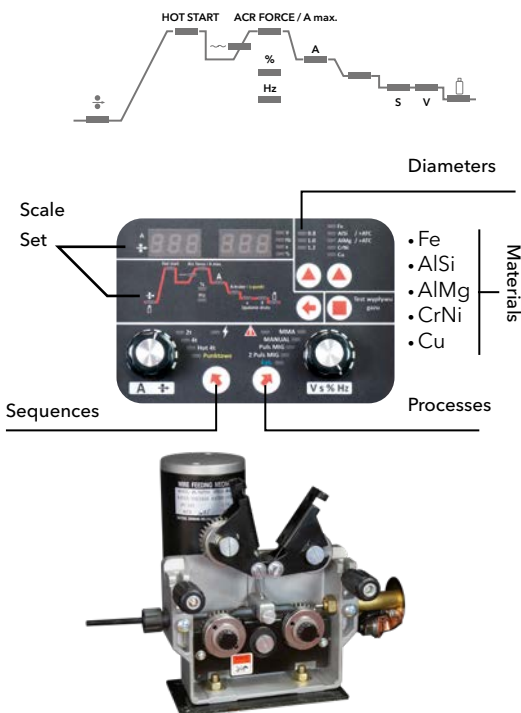

	MIG 280 DOUBLE PULSE	MIG 350 DOUBLE PULSE
Output Power	280 A	350 A
Voltage	3 x 400 V	3 x 400 V
Duty Cycle	60 %	60 %
Coated electrodes	1.6 - 6.0 mm	1.6 - 8.0 mm
Wire thickness	0.8 - 1.0 - 1.2 - 1.6 mm	0.8 - 1.0 - 1.2 - 1.6 mm
Coil weight	5 - 15 kg	5 - 15 kg
Generator use	14 KVA / 230V ±17%	15 KVA / 230V ±17%
Size	53 x 64 x 29.5 cm	77.5 x 94 x 40 cm
Weight	34 kg	46.5 kg
DINSE Connector	1/2" (35 - 50) ø	1/2" (35 - 50) ø
Power cable	2.5m - 2.5 mm ² + 1 - 1.5 mm ²	3m - 2.5 mm ²
Cable + Earth clamp	2m - 25 mm ²	2.5m - 25 mm ²
Cable + Electrode clamp	3m - 25 mm ²	2.5m - 25 mm ²
MIG Torch Aluminum	INNOTEK 24 / 2m x 25 mm ²	36KD - 2m
MIG Torch Steel	INNOTEK 24 / 4m x 25 mm ²	36KD - 3m
Rollers V	x2 (0.8 / 1.0) x2 (1.2 / 1.6) mm	x2 (0.8 / 1.0) mm
Rollers U	x4 (1.0 / 1.2) mm	x4 (1.0 / 1.2) mm

Industrial Inverter three-phase welding equipment for non stop wire welding, MMA & MIG, Intelligent synergic settings 60% duty cycle.

- Synergic system suitable for all kind of carbon steel & inox, magnesium / silicon aluminums & copper.
- Specific settings for coated electrodes MMA, pulse / double pulse & manual mode. Spray mode with no splatting on all kind of positions with pulse control.
- Sequence modes included: 2T, 4T, 4TH & Spot.
- Optimized settings for 0.8, 1.0, 1.2, 1.6 mm wire.
- Included external **Hot Start & Arc Force** regulation for professional **MMA welding**.
- Includes two Torches 25mm². A short one special for aluminum & other one for steels.
- Four contacts roller 'U' special for aluminum & 'V' special steel.
- Advanced modular managed by 2 Microprocessors for a long lifespan.
- Easy transport & storage: Compact tool & low mass. Included gas tank tray
- Designed and produced under european regulations 2014/35/UE, 2014/30/EU & 2011/65/EU.
- Temperature & overcharge protection controlled by software.
- Ready for Stabilized generators use, with a voltage input deviation of +/-17%.
- Low consumption: Max 15 Amperes per phase.



CUTTING WITH PLASMA

Model	PLASMA MULTI 40	PLASMA 40 COM GE	PLASMA 100 TGE
Code	1.1537	1.1732	1.1538
Input 50 / 60 Hz Phases	1	1	3
Voltage (V)	230	230	400
Duty Cycle STAYER 30°C (%)	60	60	60
Max. Current (A)	Plasma 40 Electrode 160	40	100
Max generator (KVA)	7	7	11
Recommended Generator (AVR)*	7	7	12
Max. intake Input (A) I_{1max}	31	31	28
Cutting capacity	12	12	32
Coated Electrode (MMA)	✓	X	X
TIG Lift Arc	✓	X	X
Built-in Compressor	X	✓	X
High Frequency cutting (HF)	X	X	✓
Air hose	3.25	✓	✓



* Recommended values using Generators AVR (Automatic Voltage Regulator).

Minimum values recommended obtained using the welding equipment at minimum performance in a controlled environment under specific conditions.

For an optimum tool usage we advise using an AVR generator capable of providing maximum intake KVA for the tool.

INVERTER PLASMA CUTTERS

PLASMA 40 COM GE

Cod. 1.1537

PLASMA MULTI 40 GE

Cod. 1.1732

PLASMA 100 TGE

Cod. 1.1538



	PLASMA MULTI 40 GE	PLASMA 40 COM GE	PLASMA 100 TGE
Output Power	40 - 160 A	40 A	100 A
Voltage	230 ±17% V	230 V	3 x 400 V
Duty Cycle	60 %	60 %	60 %
Coated electrodes	1.6 - 4.0 mm	X mm	X mm
Cutting capacity	12 mm	12 mm	32 mm
Built-in compressor	X	1 HP	X
Generator use	7 KVA / 230V ±17%	7 KVA / 230V ±17%	12 KVA / 230V ±17%
Size	39.5 x 27.5 x 15 cm	35 x 40 x 19.5 cm	62 x 50 x 32 cm
Weight	7 kg	19.5 kg	30 kg
DINSE Connector	1/2" (35 - 50) ø	3/8" (10 - 25) ø	3/8" (10 - 25) ø
Power cable	3m x 2.5 mm ²	3m x 2.5 mm ²	3m x 2.5 mm ²
Cable + Earth clamp	2m - 16 mm ²	3m - 10 mm ²	3m - 16 mm ²
Cable + Electrode clamp	2.4m - 16 mm ²	X	X
Torch Plasma	SG 55 / 4m	IPT 40 / 6m	LT 100 / 6m
TIG Torch	SR 17 HF	X	X
Air hose	X	✓	✓

- Professional Plasma metal cutting system by Inverter technology.
- Ready for clean and fast cuts of all kind of metals and alloys execution.
- Solid construction under European specifications: 2014/35/EU, 2014/30/EU, 2011/65/EU and IEC 60974.
- Fabricated for production works in severe-service industrial production for metallic constructions, yards, scrapping, boiler making and maintenance.
- 40A and 100A at 60% duty cycle with 100 to 130 Vdc no-load voltage.
- Easy cutting operations execution even for inexperienced users due to the ST WELDING smart logic.
- The PLASMA 40 COM GE mobility equipment includes an intern 1 HP internal compressor for autonomy, with no need for the equipment to be connected to the compressed air installation.
- Metallic carpentry and extra robust housing with inner reinforcement for shock bearing. Steel blades for a higher resistance and longer service life.
- Advanced design and high-quality electronical components, including commutators and high-range HF rectifiers, toroidal power transformers and top brand components. Modular design for easy service.
- Extended resistance to the power input. Bears up to 270Vac in monophasic equipment and up to 470Vac in triphasic ones under 50m extension cords conditions.
- Ready for all kind of capacitor stabilized generators, AVR or sine-wave inverter
- Every model includes cutting torches, air hose and earth clamp cables.

PLASMA MULTI 40 Three functions:

- MMA covered electrode welding with external Arc Force and 160A at 60% duty cycle cellulosic welding.
- Quality TIG welding with arc start by contactless high frequency.
- All kind of metals cutting by HF 40A contactless start-up Plasma.
- Very complete accessories including plasma torch, TIG torch and MMA.
- Suitable for all kind of light and medium and heavy maintenance and construction works where a maximum welding, cut and usage simplicity is required.

FIXED PROTECTION - MASKS

GS-0B (5 Masks indivisible pack)

Cod. 1.2689

ANZI 2000 (5 Masks indivisible pack)

Cod. 8110.3310

	GS-0B		ANZI 2000	
Filter	108 x 50 x 3	mm	107 x 50.5	mm
Vision Area	93 x 40	mm	89 x 45	mm
Light mode protection	11	DIN	10	DIN
Dark mode protection	11	DIN	10	DIN
Protection UV/IR	11	DIN	10	DIN
Time light > dark	-	s	-	s
Time dark > light	-	s	-	s
Adjustable sensitivity	X		X	
Usage temperature	-5 / +55	°C	-5 / +55	°C
Weight	400	gr	275	gr
Filter lifespan	2 Years		2 Years	
Units per box	x5		x5	



AUTOMATIC MASK WITH ADJUSTABLE SENSITIVITY

AS - 1D

Cod. 1.1841

Filter	110 x 90	mm
Vision Area	92 x 35	mm
Light mode protection	4	DIN
Dark mode protection	9 / 13	DIN
Protection UV/IR	15	DIN
Time light > dark	1 / 20000	s
Time dark > light	0.2 - 0.8	s
Adjustable sensitivity	✓	
Usage temperature	-5 / +55	°C
Weight	440	gr
Filter lifespan	2 Years	
Battery Filter	Solar / AAA	
Suitable for Grinding	X	



AUTOMATIC MASK WITH ADJUSTABLE SENSITIVITY

AS - R

Cod. 1.1792

Filter	110 x 90 x 8	mm
Vision Area	92 x 35	mm
Light mode protection	4	DIN
Dark mode protection	9 / 13	DIN
Protection UV/IR	15	DIN
Time light > dark	1 / 20000	s
Time dark > light	0.4	s
Adjustable sensitivity	X	
Usage temperature	-5 / +55	°C
Weight	500	gr
Filter lifespan	2 Years	
Battery Filter	Solar / AAA	
Suitable for Grinding	✓	



AUTOMATIC MASK WITH ADJUSTABLE SENSITIVITY

AS - RT

Cod. 1.2151

CARNIVAL 1 (AUTO)

Cod. 1.2025

CARNIVAL 3 (FIRE)

Cod. 1.2024

Filter	110 x 90 x 8	mm
Vision Area	92 x 35	mm
Light mode protection	4	DIN
Dark mode protection	9 / 13	DIN
Protection UV/IR	15	DIN
Time light > dark	1 / 20000	s
Time dark > light	0.2 / 0.8	s
Adjustable sensitivity		✓
Usage temperature	-5 / +55	°C
Weight	500	gr
Filter lifespan	2 Years	
Battery Filter	Solar / AAA	
Suitable for Grinding		✓



AUTOMATIC MASK WITH MANUAL ADJUSTABLE SENSITIVITY

AS - X

Cod. 1.1059

Filter	110 x 90 x 9	mm
Vision Area	91 x 41	mm
Light mode protection	4	DIN
Dark mode protection	9 / 13	DIN
Protection UV/IR	16	DIN
Time light > dark	1 / 25000	s
Time dark > light	0.2 / 0.8	s
Adjustable sensitivity		✓
Usage temperature	-5 / +55	°C
Weight	430	gr
Filter lifespan	2 Years	
Battery Filter	Solar / AAA	
Suitable for Grinding		✓



- Automatic external and internal regulation
- Solar powered filter
- Ready for grinding jobs
- Adjustable darkening, 2 ranges precision
- Sensibility and delay control
- Large frontal protector

AUTOMATIC MASK WITH MANUAL ADJUSTABLE SENSITIVITY

AS - XL

Cod. 1.1386

Filter	114 x 133	mm
Vision Area	100 x 60	mm
Light mode protection	4	DIN
Dark mode protection	5-9 / 9-13	DIN
Protection UV/IR	16	DIN
Time light > dark	1 / 30000	s
Time dark > light	0.2 / 0.8	s
Adjustable sensitivity		✓
Number of sensors	4	
Usage temperature	-5 / +55	°C
Weight	440	gr
Filter lifespan	2 Years	
Battery Filter	Solar / 2xCR2450	
Suitable for Grinding		✓



- Great surface vision
- Recommended for TIG welding
- Solar powered filter
- Ready for grinding jobs
- Large frontal protector
- Area filter of 100 x 60mm adjustable
- 4 arc sensors.
- Rechargeable batteries

ELECTRODES

Code	Description	mm	Box Kg
38.944	RUITILO E-6013	2.5	1
38.945	RUITILO E-6013	3.2	1
38.946	RUITILO E-6013	4.0	1
38.852	RUITILO E-6013	2.5	5
38.853	RUITILO E-6013	3.25	5
38.854	RUITILO E-6013	4.0	5

Code	Description	mm	Box Kg
38.947	BÁSICO E-7018	2.5	1
38.948	BÁSICO E-7018	3.2	1
38.857	BÁSICO E-7018	3.2	5

Code	Description	mm	Box Kg
38.949	INOX E-308L-16	2.5	1
38.950	INOX E-308L-16	3.2	1
38.864	INOX E-308L-16	3.25	4.5

Code	Description	mm	Box Kg
38.865	ALUMINIO	2.5	2
38.866	ALUMINIO	3.2	2



FLUX CORE COILS

0.9 mm / 0.45 kg / E71T - GS ISO-EN-17632

Cod. 2.780

0.9 mm / 1 kg / E71T - GS ISO-EN-17632

Cod. 2.769

0.9 mm / 5 kg / E71T - GS ISO-EN-17632

Cod. 2.768

1.2 mm / 15 kg / E71T - 1C

Cod. 2.796



STEEL WIRE COILS

0.8 mm / 1 kg / ER70S - 6

Cod. 2.767

0.8 mm / 5 kg / ER70S - 6

Cod. 2.765

1.0 mm / 1 kg / ER70S - 6

Cod. 2.772

1.0 mm / 5 kg / ER70S - 6

Cod. 2.766



TUNGSTEN ELECTRODES (10 Uds)

2% Thorium \varnothing 1.6 x 150 mm - EWTh-2 - RED

ANSI/AWS A5.12M-98 ISO 6848

Cod. 2.250

2% Thorium \varnothing 2.4 x 150 mm - EWTh-2 - RED

ANSI/AWS A5.12M-98 ISO 6848

Cod. 2.303

Pure Tungsten \varnothing 1.6 x 150 mm - EWP - GREEN (Aluminum)

ANSI/AWS A5.12M-98 ISO 6848

Cod. 2.781

Pure Tungsten \varnothing 2.4 x 150 mm - EWP - GREEN (Aluminum)

ANSI/AWS A5.12M-98 ISO 6848

Cod. 2.430



FILLER RODS

Carbon Steel \varnothing 1.6mm x 1m ER70S - 6 (1 Kg)

Cod. 2.784

Inox (10 Uds) 316L

Cod. 2.803



Consumables for Welding Masks

Cod.	Model	Internal Protector	External Protector	Filter	Harness	Harness fixation set	Sweat band
1.1792	AS - R	4020.57	4020.8	4020.53	4020.55	4020.56	4020.32
1.2151	AS - RT	4020.57	4020.8	4020.61	4020.55	4020.56	
1.1606	AS - 1D	4020.59	4020.58	4020.61	4020.60	4020.56	
1.1059	AS - X	4020.13	4020.8	4020.18	4020.19	4020.24	
1.1386	AS - XL	4020.30	4020.29	4020.27	4020.42	4020.43	



MAGNETIC SQUARE

<25 kg
Cod. 8110.777



CHISEL / HAMMER

500 gr
Cod. 8110.1225



HAMMER / BRUSH

Cod. 8110.1226



FLOWMETER

Argón & CO2
Cod. 38.875



ELECTRODE CLAMP

300A
Cod. 8110.637
400A
Cod. 38.259

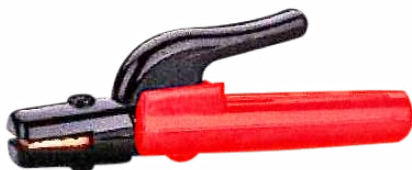

EARTH CLAMP

300A
Cod. 8110.638
500A
Cod. 8110.1228



MALE DINSE CONNECTOR

3/8" (x2 Uds)
Cod. 38.232
1/2"
Cod. 38.233



FEMALE DINSE CONNECTOR

3/8" (x2 Uds)
Cod. 2.552
1/2"
Cod. 2.680



CABLES & CLAMPS SET

8110.3345 8110.3308 8110.1159 8110.3309

Cable + Earth clamp	2m x 16mm ²	3m x 16mm ²	2m x 25mm ²	3m x 25mm ²
Cable + Electrode clamp	2.5m x 16mm ²	4m x 16mm ²	3m x 25mm ²	4m x 25mm ²
DINSE Connector	3/8" (10-25)	3/8" (10-25)	1/2" (25-50)	1/2" (25-50)



PLASMA TORCHES M16 x 1.5

PLASMA SG 55 (4m) para PLASMA 40 MULTI GE

Cod. 4120.170

PLASMA IPT 40 (6m) para PLASMA 40 COM GE

Cod. 4120.171

PLASMA LT 100 (6m) para PLASMA 100 TGE

Cod. 4120.169



PLASMA SG 55



PLASMA IPT 40



PLASMA LT 100

Consumables for Torches PLASMA

Cod.	Model	Electrode	Swirl ring	Nozzle Tip	Nozzle shield cup	Swirl ring support	Separator	Nozzle
4120.170	SG 55	4120.180			4120.178			4120.179
4120.171	IPT 40	4120.174	4120.175	4120.176	4120.177			
4120.169	LT 100	4120.148	4120.145	4120.146	4120.147	4120.144	38.21	

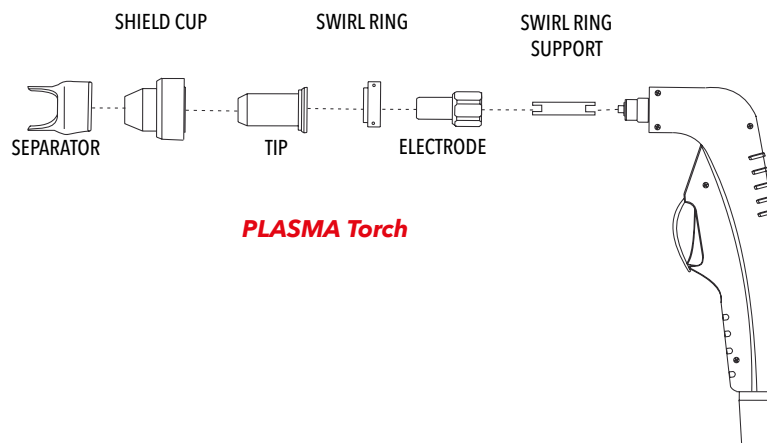

CONTACT TIPS

Steel 0.8mm - 5 units

Cod. 2.782

Steel 0.9mm - 5 units

Cod. 2.783

Steel 1.0mm - 5 units

Cod. 2.786



CONIC NOZZLES MIG 15

3 units

Cod. 2.787



MIG Torch
13 AK - 3m
EUROTORCH
MIG 160 MULTI

Cod. 8110.1158



MIG Torch
15 AK - 4m
EUROTORCH
MIG 165/170/200 MULTI

Cod. 38.483



MIG Torch
25 AK - 4m
EUROTORCH
MIG 250 C

Cod. 38.484



MIG Torch
36 AK - 4m
EUROTORCH
MIG 350 BT
MIG 350 DP

Cod. 38.485



MIG Torch
Aluminum - 36 AK - 3m
EUROTORCH
MIG 350 DP

Cod. 38.806



MIG Torch
MIG 501 D - 3m
EUROTORCH
MIG 500 BT

Cod. 38.308



MIG Torch
MIG 24 - 4m
EUROTORCH
MIG 200 DP
MIG 280 DP

Cod. 8346.55



MIG Torch
Aluminum - MIG 24 - 2m
EUROTORCH
MIG 200 DP
MIG 280 DP

Cod. 8346.56



Cod.	Torch	Tool	Nozzle	Contact Tip Steel			Contact Tip Aluminum			Tip Holder	Neck	Switch	Steel Liner			Aluminum Liner		
				0.8	1.0	1.2	0.8	1.0	1.2				0.8	1.0	1.2	0.8	1.0	1.2
8110.1158	13 AK	MIG 170	8110.1165	8110.1162	8110.1163	8110.1164				8110.1166	8110.1167	8110.1168						
38.483	15 AK	MIG 200	4019.56	38.50	38.51		38.52	38.53		38.721	38.742	38.613	38.744			38.743		
38.484	25 AK	MIG 250 C	38.81	38.54	38.55	38.56	38.57	38.745	38.58	38.722	38.746	38.747						
38.485	36 AK	MIG 350 BT	38.69	38.59	38.60	38.61	38.62	38.63	38.64	38.480	38.752		38.750	38.751		38.749	38.748	
38.486	501 D	MIG 500 BT	38.568	38.542	38.543	38.544	38.545	38.66	38.546	38.736	38.737		38.553	38.556	38.559	38.554	38.557	38.560

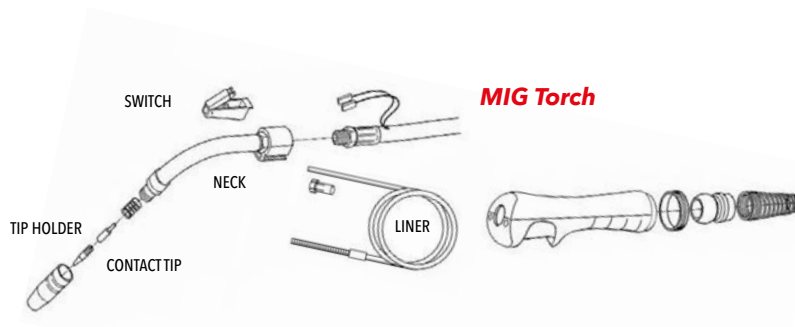



TIG Torch
DINSE 3/8"
Gas 1/2" - 3m
UNIVERSAL
 Cod. 38.85



TIG Torch
DINSE 1/2"
Gas 1/2" - 4m
UNIVERSAL
 Cod. 38.87



TIG Torch
PLASMA MULTI 40 COM
DINSE 1/2"
M16 x 1.5 - 4m
 Cod. 4120.172



TIG Torch
POTENZA TIG 170 HF
Gas M16 x 1.5 - 4m
 Cod. 38.713



TIG Torch
TIG 200 HFP
TIG AC/DC 190 HFPS
TIG AC/DC 200 HFP
DINSE 1/2"
Gas M10 x 1 - 3m
 Cod. 4019.55



TIG Torch
Water DINSE 1/2"
Gas M10 x 1 - 3m
TIG AC/DC 315 HF P
 Cod. 4019.125



Consumables for Torches TIG

Torch	Long Cap	Valve Cap	Collet							Collet Body					Ceramic Nozzle				
			1.0	1.6	2.0	2.4	3.2	4.0	1.0	1.6	2.0	2.4	3.2	4.0	GR-4	GR-5	GR-6	GR-7	GR-8
UNIVERSAL	2.310	2.311	2.330	2.305	2.331	2.306	2.332	2.333	2.334	2.308	2.335	2.307	2.336	2.337	2.338	2.339	38.443	2.340	2.341

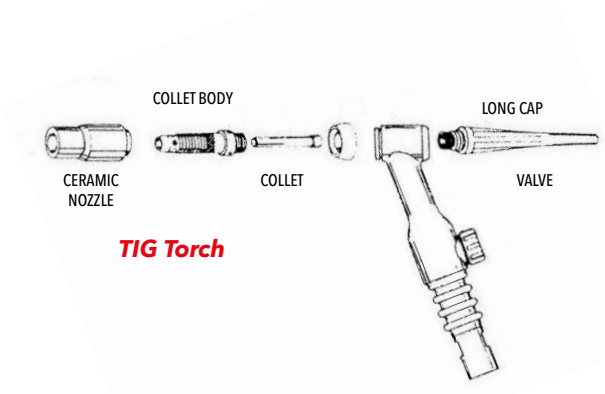

STAYER IBÉRICA S.A.
Street Sierra de Cazorla, 7
Área Empresarial, Sector 1
28320 Pinto (Madrid) Spain

Phone: 91 691 86 30

E-mail: info@grupostayer.com
www.grupostayer.com

STAYER srl
36015 Schio (VI) Italia
Via Lago di Costanza, 20

Phone: +39 0445 621 244

email: info@stayeritalia.it
www.stayeritalia.it

DESIGNED FOR **PROFESSIONALS**



This catalog is intended for Export.
The photographs in this catalog are purely indicative.
The company reserves the right to modify or change them without prior notice.
2023 - Stayer Group - Design and Marketing Department.
English see -7/2023